

# GUIDELINES

1. COALESCING PLATE SEPARATORS AND COLLECTION PIT TO BE SIZED ACCORDING TO RATE OF INFLOW. (REFER TO MANUFACTURERS SPECIFICATIONS)
2. ONLY NON EMULSIFYING TYPE PUMPS MAY BE USED WITH COALESCING PLATE SEPARATORS.
3. COALESCING PLATE SEPARATORS ARE TO DISCHARGE THROUGH A TRADE WASTE SAMPLING POINT, REFER TO TYPICAL DRAWING HX33-11-30.
4. MAINTENANCE DETAILS TO BE INCLUDED WITH THE APPLICATION TO DISCHARGE TRADE WASTE FORM.
5. ALL MEASUREMENTS SHOWN ARE IN MILLIMETRES.
6. SILT SUMPS ARE NOT RECOMMENDED TO BE USED AS COLLECTION/PUMP PITS.
7. THE CAPACITY OF THE COLLECTION PIT TO BE TWICE THE SIZE OR GREATER THAN THE SEPARATOR.
8. ALL ASSOCIATED PLUMBING WORK IS TO COMPLY WITH WATER SERVICES LICENSING (PLUMBERS LICENSING AND PLUMBING STANDARDS) REGULATIONS 2000 AND LATEST VERSIONS OF AS/NZS 3500.1 AND AS/NZS 3500.2.
9. GAS TIGHT COVERS TO COMPLY WITH LATEST VERSION OF AS 3996.
10. ALL ASSOCIATED ELECTRICAL CONNECTIONS TO COMPLY TO AUSTRALIAN STANDARDS AND TO BE INCORPORATED INTO ANY TREATMENT SYSTEM DESIGN.
11. ALL ELECTRICAL CONNECTIONS TO BE CERTIFIED BY A LICENSED TRADESPERSON OR ELECTRICIAN. WATER CORP. DO NOT CERTIFY ELECTRICAL.

FOR MORE INFORMATION REFER TO OUR TRADE WASTE WEB PAGE  
<http://www.watercorporation.com.au/tradewaste>

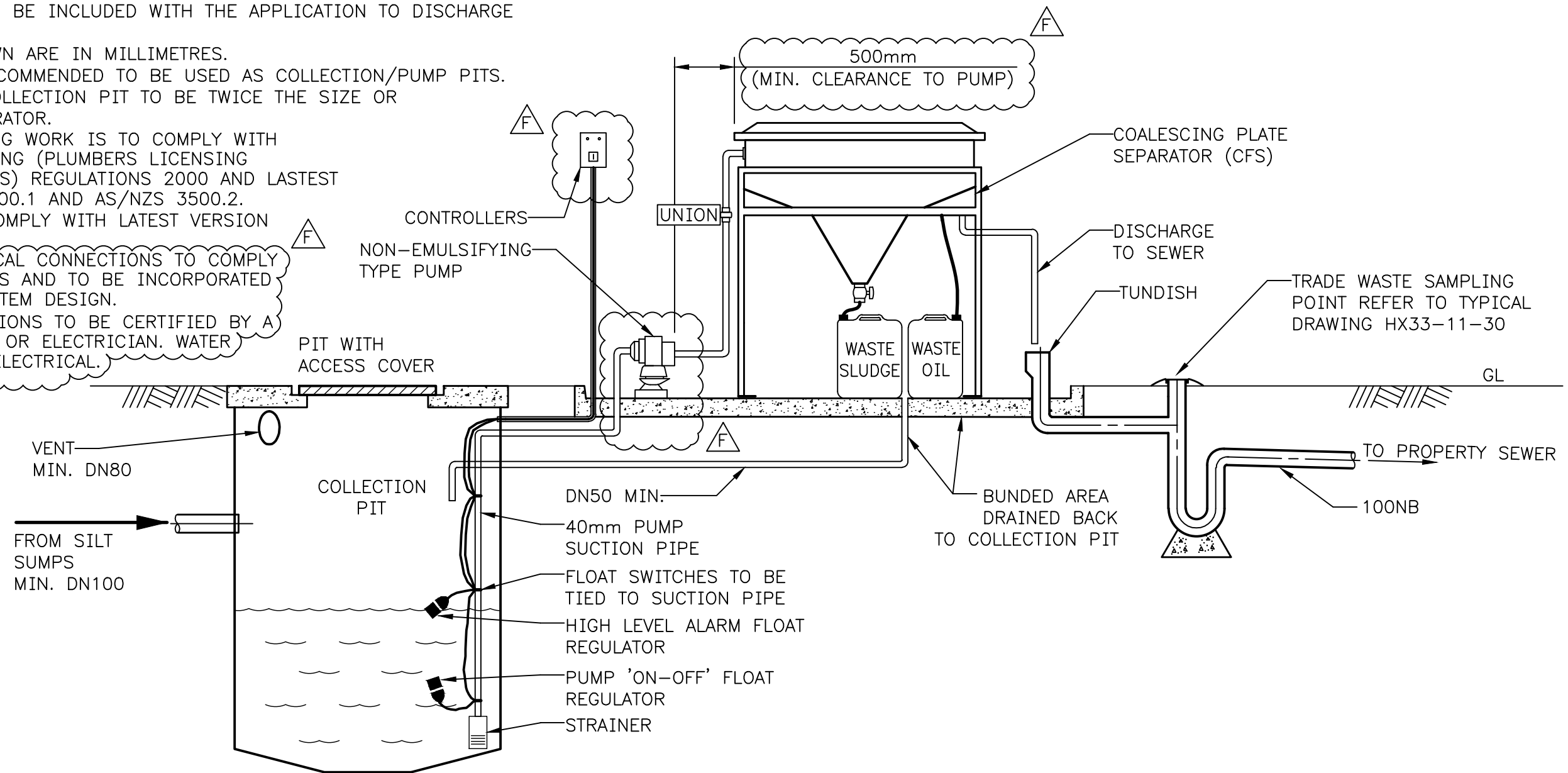

ISSUE	DATE	GRID	REVISION	DRN	REC	APPD
F	12/2017		PUMP AND CONTROLLER ARRANGEMENT AMENDED, NOTES 10 & 11 ADDED	BJ	SJ	SJ
E	07/2016		WEBSITE DETAILS ADDED, GUIDELINES AMENDED	BJ	SJ	MS
D	03/2014		WASTE SLUDGE ADDED AND ALL REFERENCES TO 'INDUSTRIAL WASTE' REPLACED WITH 'TRADE WASTE'	AC	PR	MS
C	06/2009		BUNDED AREA INCREASED. BUNDED AREA TEXT MODIFIED. NOTES 6, 7 & 8 ADDED.	RY	GC	AM
B	12/2005		TEE REMOVED	KLM	AM	VM

SCALE: DIAGRAMMATIC

DES CALC	RECOMMENDED	25/03/2014		WATER CORPORATION		ORIGINAL SHEET SIZE
DES CHD	P. RANASINGHE (SIGNED)			TYPICAL DRAWINGS FOR TRADE WASTE		
DRN	SUPERVISOR ASSESSMENT		MANAGER, TRADE WASTES	FORMERLY TYPICAL DRAWING 1210		MF
K MCGREGOR	APPROVED	25/03/2014		FILE	PLAN	
Q.C. CHD	M. STARK (SIGNED)		PROJECT	HX33-12-10		F
G CLEAVER						