

# HALGAN™ HCPS-WA COOLING PIT - WA

## Notes

1. **Product:**  
The Halgan Cooling Pit is used to cool the liquid waste water and provide a discharge to the sewer of not more than 38 o C. The inlet and outlet design provide mixing of the waste water. The Halgan Cooling Pit is manufactured from polyethylene.
2. **Application:**  
The Halgan Cooling Pit is used for treatment of waste water from Launderette, Commercial/Industrial laundry and boiler blow down. In some applications where large quantities of hot waste water is discharged, it may be required to install a cooling tower to lower the temperature.
3. **General**
  - 3.1. Tank constructed from Polyethylene.
  - 3.2. The Cooling Pit is to be installed in a location that will not cause a nuisance, obstruct fire access, cannot be vandalised or be damaged by vehicles.
  - 3.3. The Cooling Pit must have ease of access to pumpout point for maintenance.
  - 3.4. A hose tap fitted with RPZD backflow protection (as per AS/NZS 3500) must be installed within 5 metres of the Cooling Pit for maintenance and cleaning.
4. **Installation above ground**
  - 4.1. The Cooling Pit is to be supported on a 100mm thick concrete pad. A stand is available for the Halgan S Series Cooling Pit if required.
  - 4.2. Any maintenance platform must be installed in accordance with Australian Standard 1657-1992 allowing safe access while inspecting and maintaining the Cooling Pit.
  - 4.3. All pipes connecting to the Cooling Pit shall be fully supported, there shall be no stress on the tank connections.
  - 4.4. All stormwater must be diverted away from the Cooling Pit to prevent undermining of foundation.
5. **Installation below ground**
  - 5.1. All connections to the Cooling Pit shall be in accordance with the appropriate authorities.
  - 5.2. Any excavation exceeding 1,5 metres in depth shall comply with the construction safety acts and regulations before backfilling.
  - 5.3. The Cooling Pit must be filled with water prior to backfilling.
6. **Excavation dimensions**
  - 6.1. The excavated hole width shall be kept as narrow as practicable. The depth shall not be greater than 150mm more than the required depth.
  - 6.2. 75mm clearance is required at the sides of tank.
7. **Over excavation**
  - 7.1. Where an excavation has been made deeper than required, the excess depth shall be filled either with 4:1 sand cement compacted to achieve 98% compaction or concrete
8. **Water Charged Ground**
  - 8.1. Where installation is in high water table or water charged ground, mine subsidence, filled or unstable areas, the services of a qualified structural engineer is required for certification.
9. **Bedding material**
  - 9.1. The bedding/backfill material shall be Blue Metal granular material up to 10mm diameter.
  - 9.2. The bedding/backfill shall be minimum 75mm thick.
  - 9.3. The bedding/backfill shall be thoroughly compacted by tamping at 300mm layers.
  - 9.4. The bedding/backfill material shall encase the whole tank.
  - 9.5. Foreign material such as builder's waste, bricks, and concrete shall not be used as backfill.
  - 9.6. The backfill shall be compacted to restore the excavated hole as near as practicable to the normal ground.

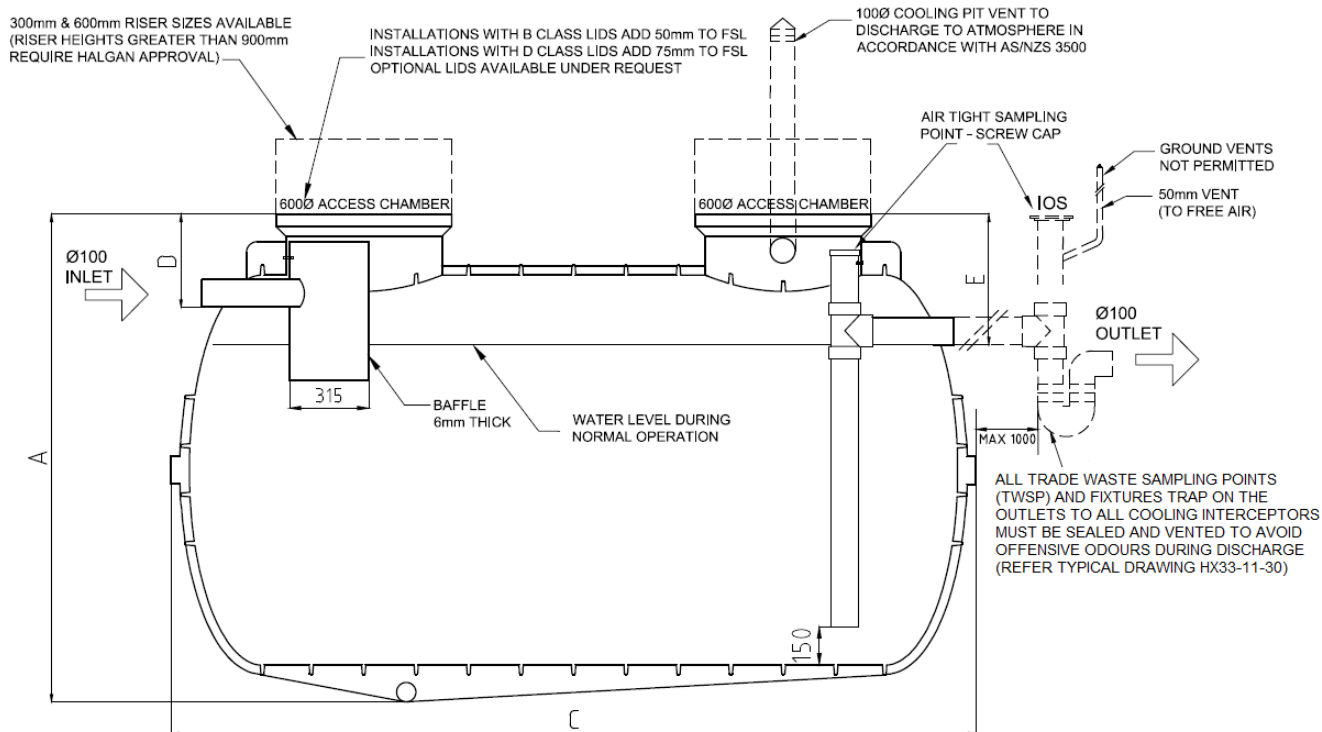

**HALGAN HCPS-WA COOLING PIT DIMENSIONS**  
DIMENSIONS DO NOT INCLUDE PIPEWORK OR ACCESS LIDS

MODEL	A	B	C	D (INLET)	E (OUTLET)	VOLUME	WEIGHT
HCPS1000-WA*	1550mm	1130mm	1700mm	380mm	530mm	1000 L	95 KG
HCPS1500-WA	1550mm	1130mm	2280mm	380mm	530mm	1500 L	125 KG
HCPS2000-WA	1550mm	1130mm	3010mm	380mm	530mm	2000 L	200 KG
HCPS3000-WA	1680mm	1365mm	3055mm	380mm	530mm	3000 L	260KG
HCPS4000-WA	1825mm	1510mm	3250mm	380mm	530mm	4000 L	310 KG
HCPS5000-WA	1940mm	1625mm	3200mm	370mm	520mm	5000 L	350 KG

\*HCPS1000-WA only has one access hatch

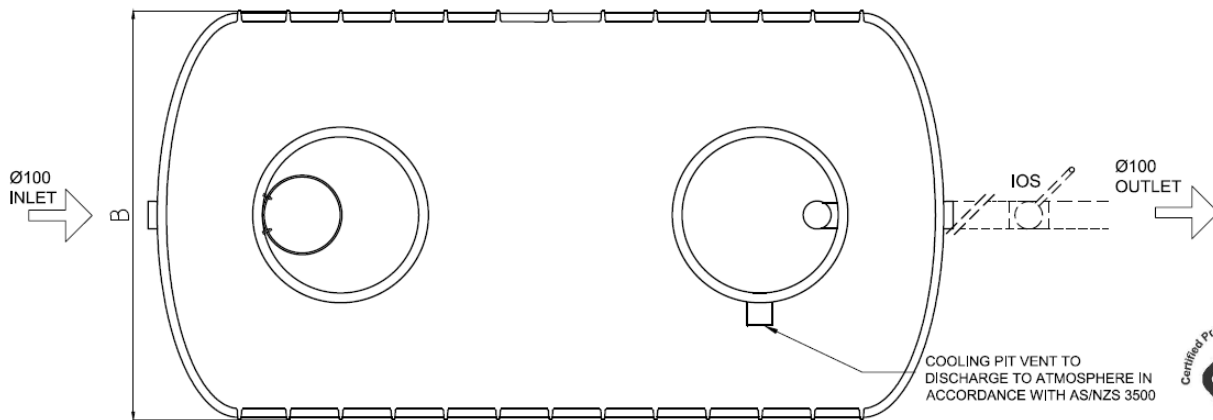

Global-Mark.com.au®  
ID NUMBER: 100896

REV	DATE	DESCRIPTION	BY	CHKD	APP
A	07.11.2016	DETAIL DESIGN	LB	JB	KH

THIS DRAWING AND THE INFORMATION CONTAINED HEREON ARE THE PROPERTY OF HALGAN PTY LTD AND MUST NOT BE COPIED, REPRODUCED OR USED WITHOUT THE WRITTEN PERMISSION OF HALGAN PTY LTD.

DO NOT SCALE IF IN DOUBT ASK



halgan pty ltd  
halgan.com.au

Freecall 1800 626 753  
22, Ethel Avenue  
Brookvale NSW 2100  
admin@halgan.com.au  
www.halgan.com.au



HALGAN HCPS-WA  
COOLING PIT DETAIL - WA

DRAWN	DATE	SCALE	REV.
LB	07.11.2016	1:20	A3
DESIGNED	JB		
DWG. NO.			
<b>HCPS-WA</b>			<b>A</b>