



Product Code:
FW-150BR

FW-150R-BASKET (Basket Only)

Great for commercial kitchens, shopping centres and hospitals. Available in 304 grade stainless steel, it suits 100mm DWV, and has a 150mm diameter round grate. It also features a fixed secondary strainer and removable basket.

Features and Benefits:

- Fixed secondary strainer
- Removable strainer basket
- Suits 100mm DWV, HDPE pipe
- In stock and available for immediate delivery



Top

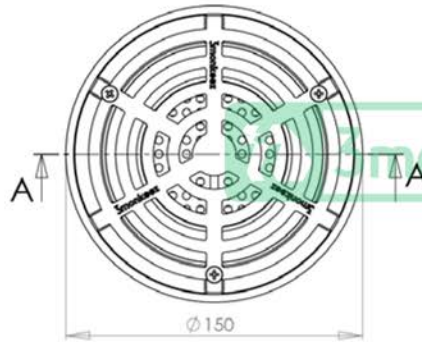

Bottom

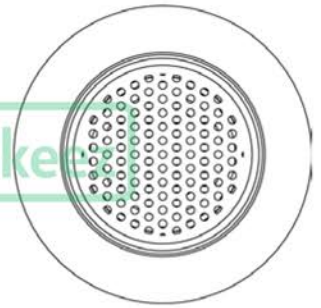

Side

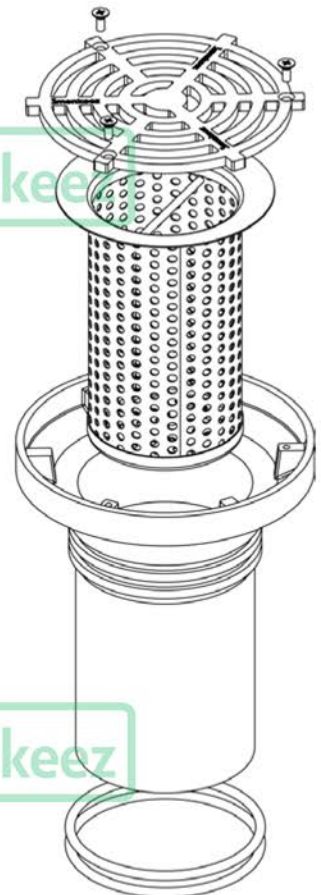
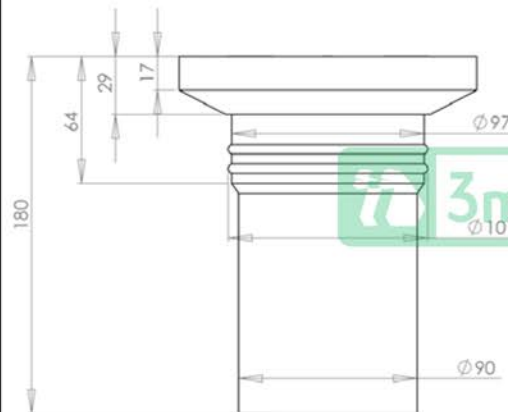

Cross Section

