

Notes

1. **General**
 - 1.1. Tank constructed from Polyethylene.
 - 1.2. The Vessel is to be installed in a location that will not cause a nuisance, obstruct fire access, cannot be vandalised or be damaged by vehicles.
 - 1.3. The Vessel must have ease of access to pumpout point for maintenance.
 - 1.4. A hose tap fitted with RPZD backflow protection (as per AS/NZS 3500).
 - 1.5. Non standard installations require Halgan approval.
2. **Installation above ground**
 - 2.1. The Vessel is to be supported on a 100mm thick concrete pad.
 - 2.2. A stand is available for S Series models if required.
 - 2.3. Any maintenance platform must be designed in accordance with Australian Standard 1657 allowing safe access while inspecting and maintaining the Vessel.
 - 2.4. All pipes connecting to the Vessel shall be fully supported; there shall be no stress on the tank connections.
 - 2.5. All stormwater must be diverted away from the Vessel to prevent undermining of foundation.
 - 2.6. Bunded compound dimensions: the vessel should be locate within a bunded compound designed to hold the total volume of the tank in case of a spillage.
3. **Installation below ground**
 - 3.1. All connections to the Vessel shall be in accordance with the appropriate authorities.
 - 3.2. Any excavation exceeding 1.5 metres in depth shall comply with the construction safety acts and regulations before backfilling.
 - 3.3. The Vessel must be filled with water prior to backfilling.
 - 3.4. Riser heights greater than 900mm require Halgan approval.
4. **Excavation dimensions**
 - 4.1. The excavated hole width shall be kept as narrow as practicable. The depth shall not be greater than 150mm and the width not greater than 75mm of the tank dimensions.
5. **Over excavation**
 - 5.1. Where an excavation has been made deeper than required, the excess depth shall be filled either with 4:1 sand cement compacted to achieve 98% compaction or concrete.
6. **Bedding/Backfill**
 - 6.1. The bedding/backfill material shall be Blue Metal granular material up to 10mm diameter.
 - 6.2. The bedding/backfill shall be thoroughly compacted by tamping at 300 mm layers.
 - 6.3. The bedding/backfill material shall encase the whole tank.
 - 6.4. Foreign material such as builder's waste, bricks, and concrete shall not be used as backfill.
 - 6.5. The backfill shall be compacted to restore the excavated hole as near as practicable to the normal ground.
7. **Water Charged Ground**
 - 7.1. Installation in areas subject to flooding & groundwater is only permitted when the level of water does not exceed the height of the middle of the tank.
 - 7.2. In areas of heavy, clay-like soils, the installation is only permitted when there is sufficient drainage underneath the body of the tank.

OWHS - HALGAN™ OIL / WATER SEPARATOR DETAIL - WA

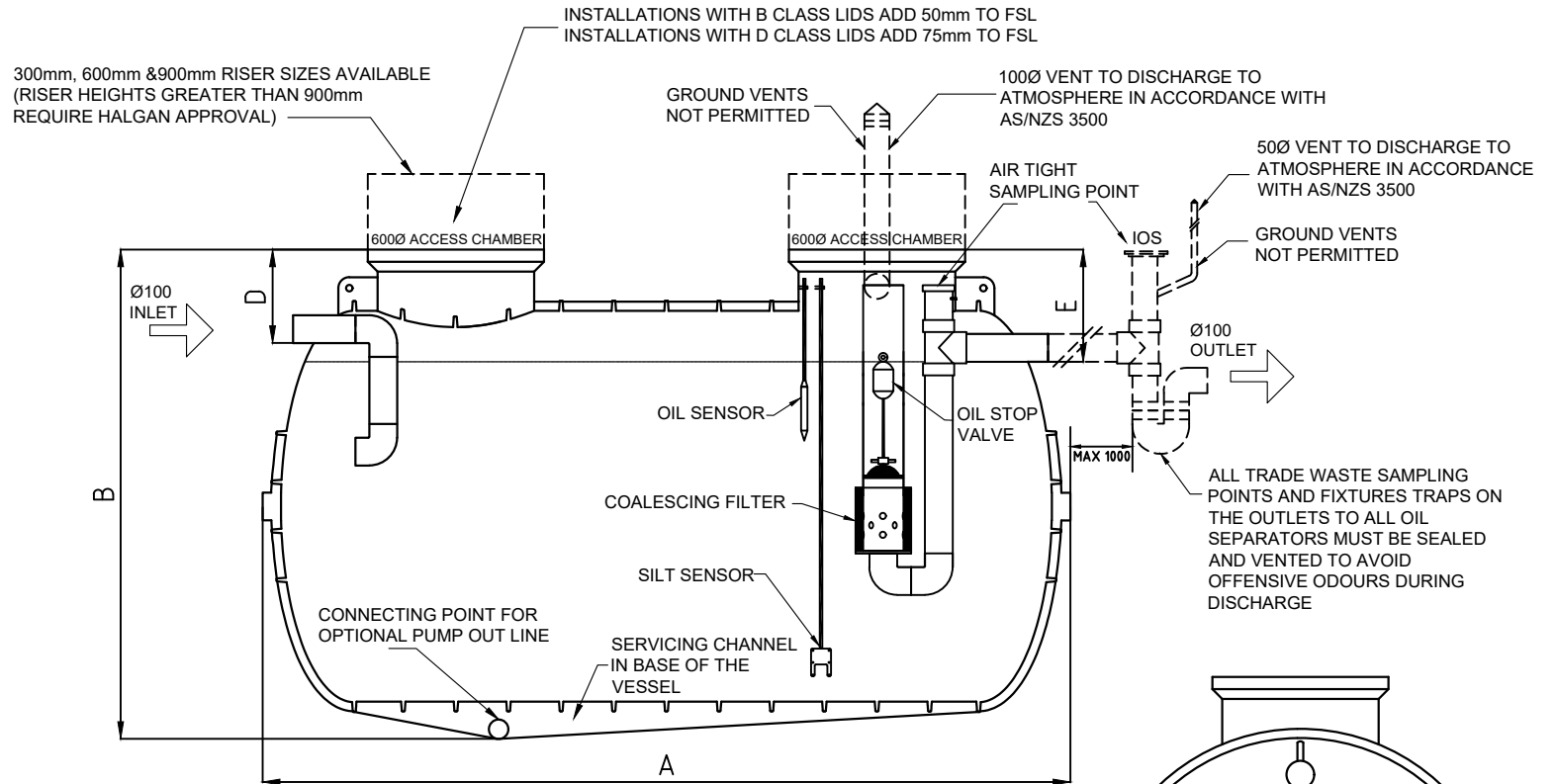

HALGAN OIL / WATER SEPARATOR DIMENSIONS							
DIMENSIONS DO NOT INCLUDE PIPEWORK OR ACCESS LIDS							
MODEL	A	B	C	D	E	VOLUME	WEIGHT
OWHS1000	1700mm	1550mm	1130mm	380mm	455mm	1000 L	95 KG
OWHS1500	2280mm	1550mm	1130mm	380mm	455mm	1500 L	125 KG
OWHS2000	3010mm	1550mm	1130mm	380mm	455mm	2000 L	200 KG
OWHS3000	3055mm	1680mm	1365mm	380mm	455mm	3000 L	260 KG
OWHS4000	3250mm	1825mm	1510mm	380mm	455mm	4000 L	310 KG
OWHS5000	3200mm	1940mm	1625mm	370mm	445mm	5000 L	350 KG

*OWHS1000 has only one access hatch

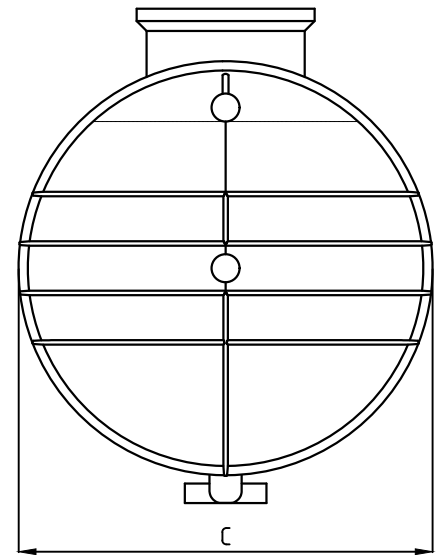

REV	DATE	DESCRIPTION	BY	CHKD	APP
V11	07.02.2019	REFERENCE UPDATE	LB	JC	KH
V10	22.01.2019	REFERENCE UPDATE	LB	JC	KH
V9	05.12.2018	NOTES UPDATE	LB	JC	KH
E	04.09.2018	DETAIL DESIGN UPDATE - OIL VALVE, OIL SENSOR, SILT SENSOR	LB	JC	KH
D	18.06.2018	DETAIL DESIGN UPDATE	LB	JC	KH

THIS DRAWING AND THE INFORMATION CONTAINED HEREON ARE THE PROPERTY OF HALGAN PTY LTD AND MUST NOT BE COPIED, REPRODUCED OR USED WITHOUT THE WRITTEN PERMISSION OF HALGAN PTY LTD.

DO NOT SCALE IF IN DOUBT ASK



halgan pty ltd
halgan.com.au

Freecall 1800 626 753
22, Ethel Avenue
Brookvale NSW 2100
admin@halgan.com.au
www.halgan.com.au

MEASUREMENTS CAN VARY ± 3%

HALGAN™ OIL / WATER SEPARATOR DETAIL - WA

DRWN	DATE	SCALE	REV.
LB	07.02.2019	-	A4
CHKD	JC	-	
DRWN	LB	-	
OWHS DETAIL			V11