

Item No.	Description	Qty.	MAK Part No.	MAK Dwg No.
1	Vessel Body	1	Z3100222	MAKOWS050-VM-001
2	Vessel Lid	1	Z3100223	MAKOWS050-VM-002
3	Vessel Stand	1	Z3100224	MAKOWS050-VM-003
4	Tube Pack Hold-down Set	1	Z3100225	MAKOWS050-VM-004
5	Skimmer Pipe	1	Z3100226	MAKOWS050-VM-005
6	DN40 PVC Coupling	1	FP-ADMI-40MM	-
7	Tube Pack (546x546x546)	3	SP-BLCK-LARGE	-
8	M6 Wing Nut 316SS	2	Z5100155	-
9	DN40 Gate Valve Brass	2	V5000101	-

Nozzle Schedule		
Nozzle No.	Description	Connection Type
N1	Raw Water Supply	DN50 BSP(F) Connection
N2	Filtered Water Out	DN80 Table 'E' Flange
N3	Vessel Drain 1	DN40 BSP(F) Connection
N4	Vessel Drain 2	DN40 BSP(F) Connection
N5	Skimmed Oil Drain Out	DN40 BSP(F) Connection

Dry Mass: 250kg
Operating Mass: 900kg

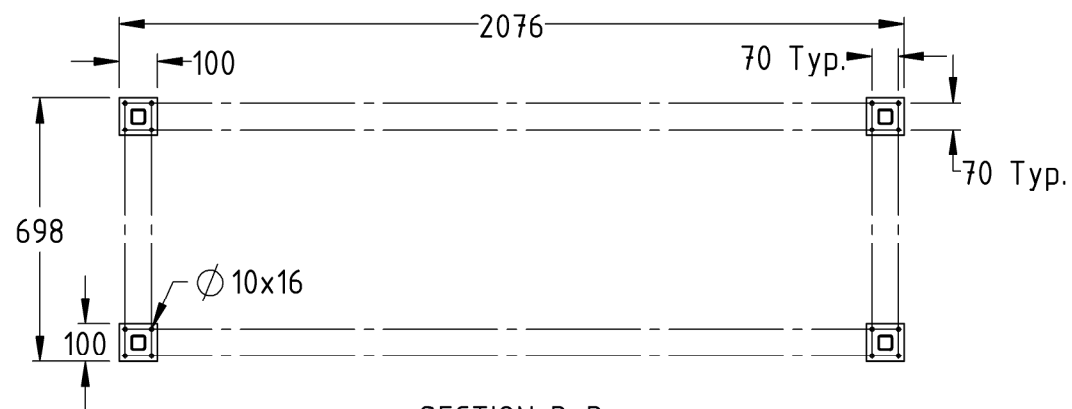
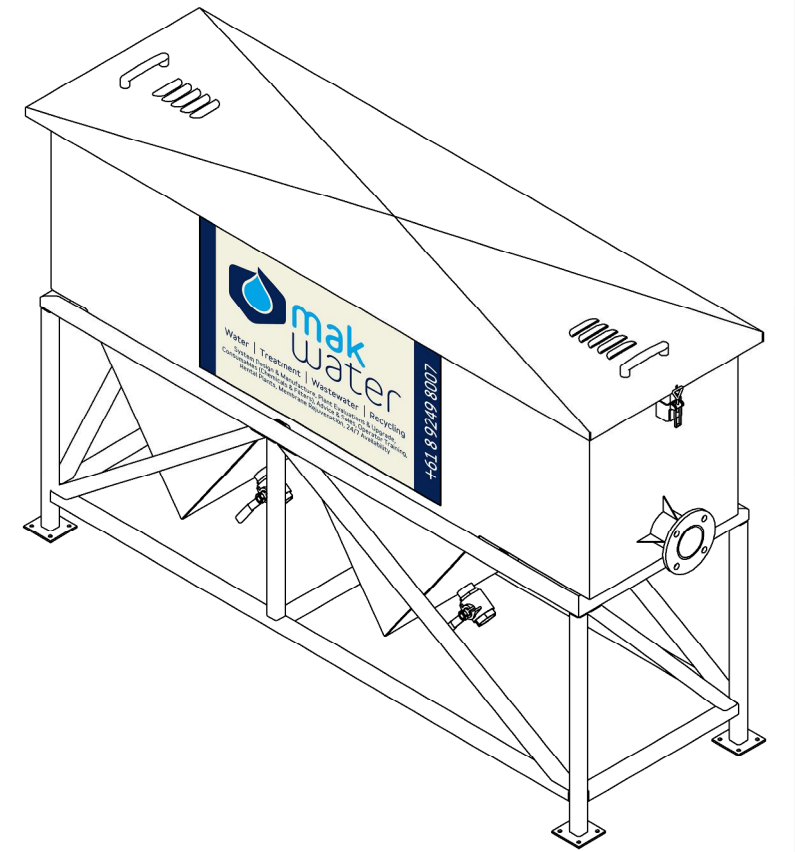

SECTION B-B

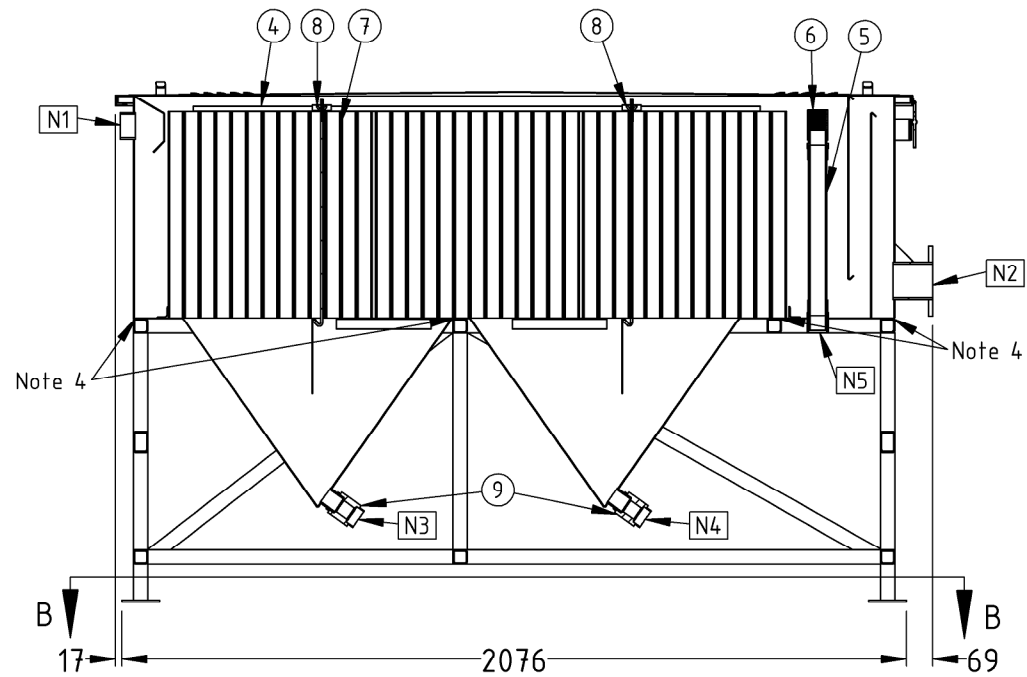
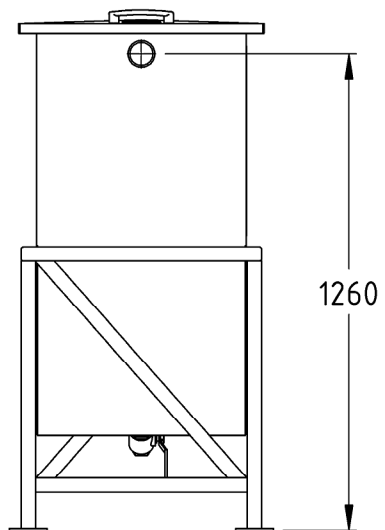
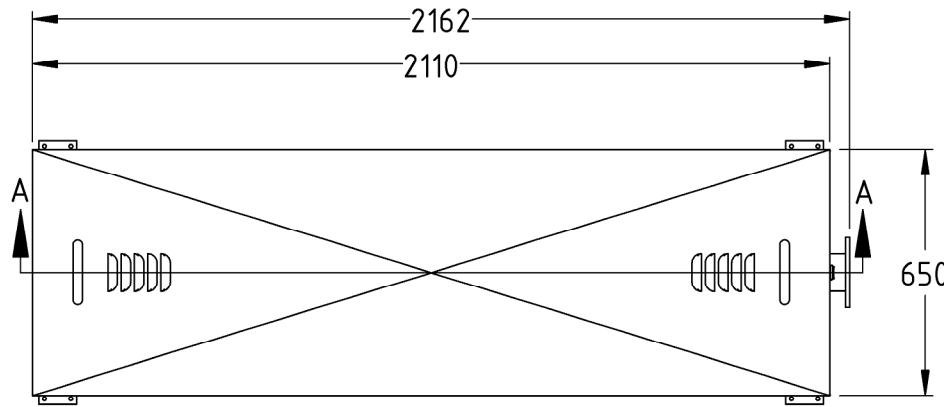

SECTION A-A

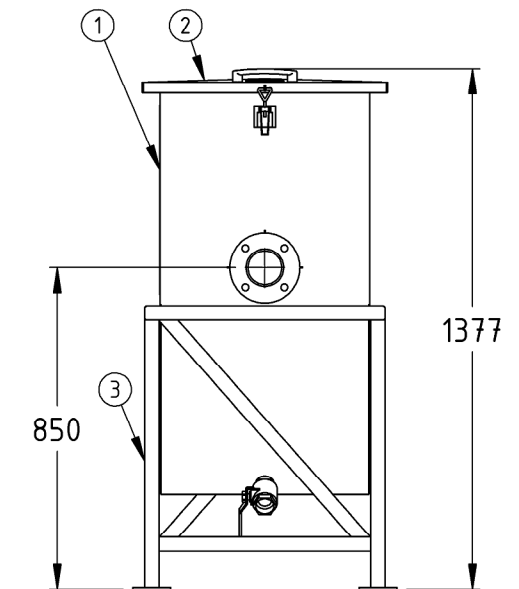

- Notes:
1. Install on level concrete surface on 20mm grout base.
 2. Fix to concrete using M8 anchor bolts (supplied by others).
 3. Connecting pipework from nozzles to be supplied by others.
 4. Isolation rubber to be installed between body and stand.

This drawing remains property of MAK Water and cannot be manufactured from, copied, or transmitted to a third party without prior written approval from MAK Water ABN 32134829280 COPYRIGHT © MAK Water 2016. PO Box 2625 Malaga WA 6944 Web: www.makwater.com.au Telephone: +61 8 9249 8007 Email: info@makwater.com.au

Reference Drawing No.	Reference Drawing Title	Rev	Date	Description	Notes	DRN	CHK	APP
MAKOWS-050-VM-005	Skimmer Pipe Fabrication Drawing							
MAKOWS-050-VM-004	Tube Pack Hold-down Set Fabrication Drawing							
MAKOWS-050-VM-003	Vessel Stand Fabrication Drawing							
MAKOWS-050-VM-002	Vessel Lid Fabrication Drawing							
MAKOWS-050-VM-001	Vessel Body Fabrication Drawing	0	25/08/2017	Issued for Construction				

mak water
a Clearmake company

Scale: 1:20
Commercial in Confidence
Paper Size: A3

Standard Product: CL5.0 Oil Water Separator
CL5.0 Oil Water Separator Assembly
General Arrangement Drawing
CM.CL5.0SSNP.304

Sheet 1 of 1
Client Document No.:
MAK Document No.: MAKOWS-050-VA-001
Rev: 0