

REVISIONS					
REV.	DESCRIPTION	DATE	DRAWN	CHECKED	APPROVED
0	APPROVED FOR CONSTRUCTION	28-02-2020	SYN	WA	WA

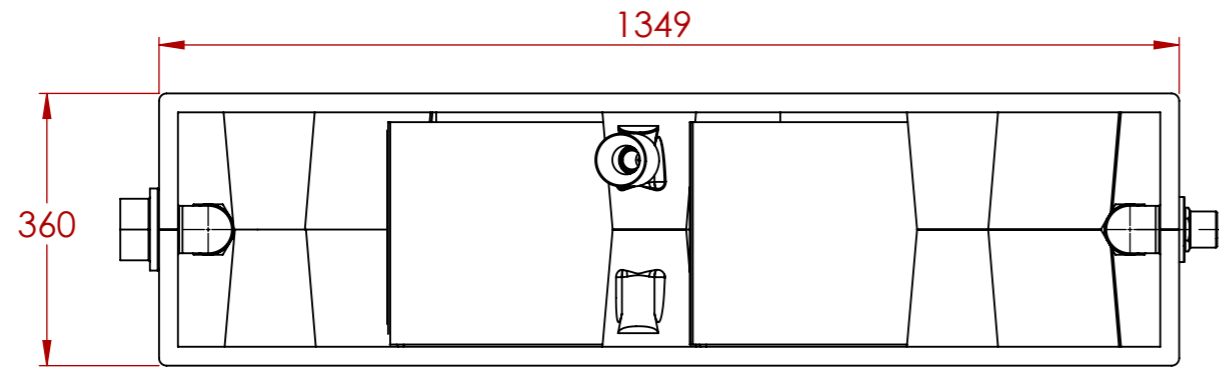

ITEM NO.	QTY	CODE	DESCRIPTION	SPECIFICATION
1	1	70382	TS 1000-2500 PE OIL WATER SEPARATOR WITH LID	POLYETHYLENE
2	2	70358	PE RETAINING MESH	POLYETHYLENE
3	1	-	SEPARATION MEDIA PACK - UPSTREAM POSITION	POLYPROPYLENE RINGS IN HDPE MESH BAGS
4	1	-	SEPARATION MEDIA PACK - DOWNSTREAM POSITION	POLYPROPYLENE RINGS IN HDPE MESH BAGS
5	1	70355	ADJUSTABLE OIL SKIMMING COLLAR	POLYPROPYLENE
6	1	71614	SEPARATOR STAND,SS 304,PE 2000, STACKING	STAINLESS STEEL
7	2	71388	DN 40 BALL VALVE	PVC
8	1	16413	20L CONTAINER,NON DANGEROUS GOODS	PLASTIC

DN50 INLET, FEMALE  
THREAD, BSP G 2"

INLET

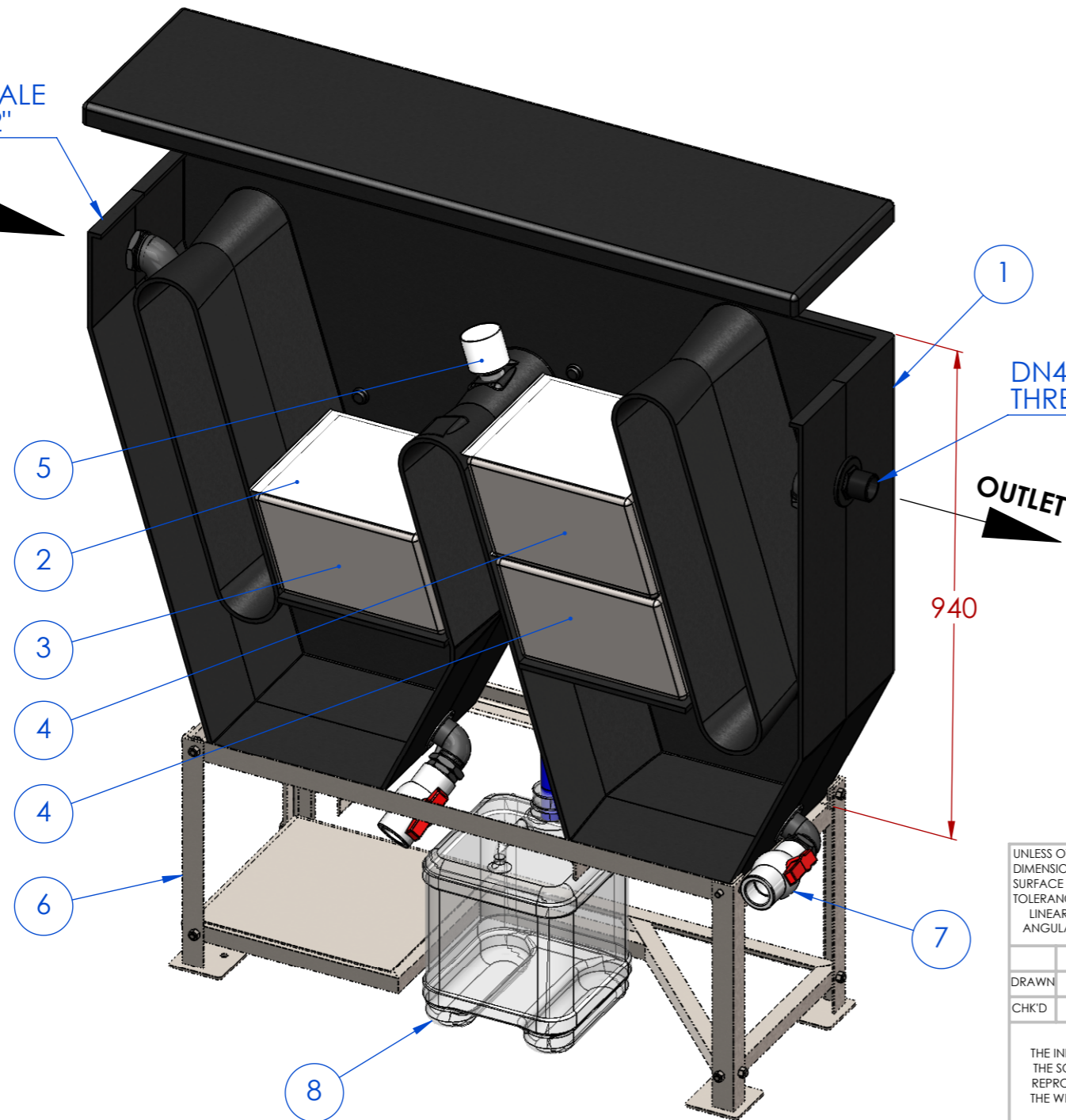

DN40 OUTLET, MALE  
THREAD BSP G 1 1/2"

OUTLET

PALL RING SIZES		
FLOW RATE(L/hr)	UPSTREAM POSITION	DOWNSTREAM POSITION
1000 & 1500	1 BAGS 25mm RINGS	2 BAGS 25mm RINGS
2000	1 BAGS 25mm RINGS	2 BAGS 16mm RINGS
2500	1 BAGS 16mm RINGS	2 BAGS 16mm RINGS

PARAMETER	VALUE
FLOWRATE AVAILABLE (L/hr)	1000, 1500, 2000, 2500

**COALESCING PLATE SEPARATORS - POLYETHYLENE - TS1000 TO TS2500**

UNLESS OTHERWISE SPECIFIED: DIMENSIONS ARE IN MILLIMETERS SURFACE FINISH: TOLERANCES: LINEAR: 0.05 mm ANGULAR: 0.10°		MATERIAL:  VARIOUS		DEBUR AND BREAK SHARP EDGES		<b>CleanaWater®</b> A3	
NAME	SIGNATURE	DATE	FINISH:	TITLE:		PE OIL WATER SEPARATOR SPECIFICATION DETAILS	
DRAWN SYN		21-02-2020	VARIOUS				
PROPRIETARY AND CONFIDENTIAL THE INFORMATION CONTAINED IN THIS DRAWING IS THE SOLE PROPERTY OF H2O CLEANAWATER. ANY REPRODUCTION IN PART OR AS A WHOLE WITHOUT THE WRITTEN PERMISSION OF H2O CLEANAWATER IS PROHIBITED.			DO NOT SCALE DRAWING		DWG NO. TSPE-DAT-001		REVISION 0
H2O CLEANAWATER, 40 LATITUDE BLVD, THOMASTOWN, VIC 3074. 1800 353 788			WEIGHT:		SCALE:1:10		SHEET 1 OF 2

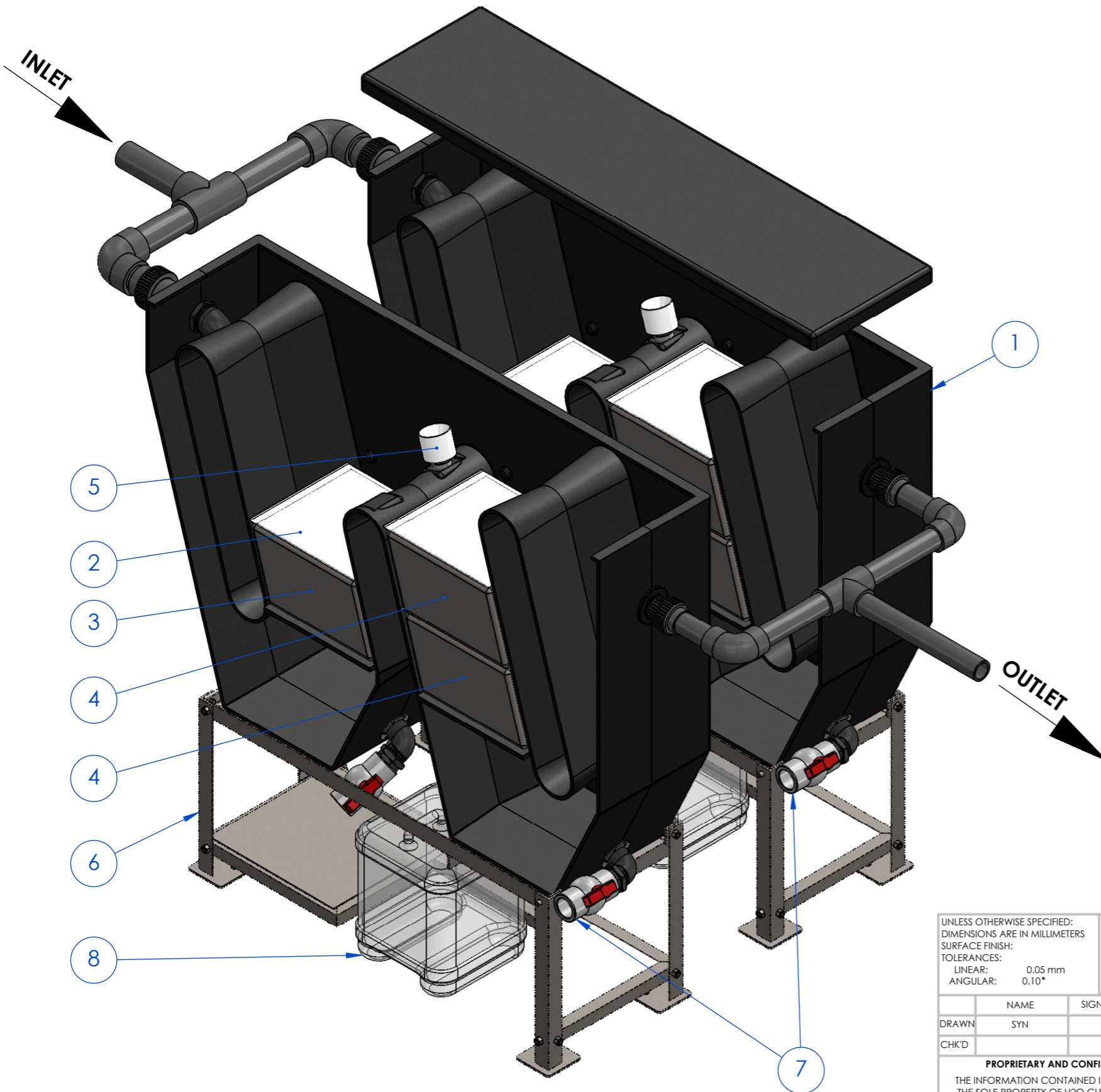

ITEM NO.	QTY	CODE	DESCRIPTION	SPECIFICATION
1	2	70382	TS 1000-2500 PE OIL WATER SEPARATOR WITH LID	POLYETHYLENE
2	4	70358	PE RETAINING MESH	POLYETHYLENE
3	2	-	SEPARATION MEDIA PACK - UPSTREAM POSITION	POLYPROPYLENE RINGS IN HDPE MESH BAGS
4	2	-	SEPARATION MEDIA PACK - DOWNSTREAM POSITION	POLYPROPYLENE RINGS IN HDPE MESH BAGS
5	2	70355	ADJUSTABLE OIL SKIMMING COLLAR	POLYPROPYLENE
6	2	71614	SEPARATOR STAND,SS 304,PE 2000, STACKING	STAINLESS STEEL
7	4	71388	DN 40 BALL VALVE	PVC
8	2	16413	20L CONTAINER, NON DANGEROUS GOODS	PLASTIC

PALL RING SIZES		
FLOW RATE(L/hr)	UPSTREAM POSITION	DOWNSTREAM POSITION
3000	2 BAGS 25mm RINGS	4 BAGS 25mm RINGS
4000	2 BAGS 25mm RINGS	4 BAGS 16mm RINGS
5000	2 BAGS 16mm RINGS	4 BAGS 16mm RINGS

PARAMETER	VALUE
FLOWRATE AVAILABLE (L/Hr)	3000, 4000, 5000

**COALESCING PLATE SEPARATORS - POLYETHYLENE - FLOW RATES BETWEEN 3000 TO 5000 L/hr**

UNLESS OTHERWISE SPECIFIED: DIMENSIONS ARE IN MILLIMETERS SURFACE FINISH: TOLERANCES: LINEAR: 0.05 mm ANGULAR: 0.10°		MATERIAL:  VARIOUS		DEBUR AND BREAK SHARP EDGES		<b>CleanaWater®</b> A3	
NAME	SIGNATURE	DATE	FINISH:	TITLE:			
DRAWN SYN		21-02-2020	VARIOUS	PE OIL WATER SEPARATOR SPECIFICATION DETAILS			
CHK'D				DO NOT SCALE DRAWING		REVISION	
<b>PROPRIETARY AND CONFIDENTIAL</b> THE INFORMATION CONTAINED IN THIS DRAWING IS THE SOLE PROPERTY OF H2O CLEANAWATER. ANY REPRODUCTION IN PART OR AS A WHOLE WITHOUT THE WRITTEN PERMISSION OF H2O CLEANAWATER IS PROHIBITED.			DWG NO.		TSPE-DAT-001		0
H2O CLEANAWATER, 40 LATITUDE BLVD, THOMASTOWN, VIC 3074. 1800 353 788			WEIGHT:		SCALE:1:20		SHEET 2 OF 2