

HAIGH

Hygienic Solutions



QUATTRO[®]
Bedpan Disposal Technology



www.haigh.co.uk

WRAS
APPROVED
PRODUCT

Important

This technical/maintenance manual is to be regarded by the owner/operator as an integral part of the equipment, which must be available for use by the owner/service engineer as required. It must be available during the life of the equipment and passed to any subsequent owner/user if the equipment is sold or transferred elsewhere.

Warranty

Our warranty provides a guarantee against defects in manufacture for the period of warranty from the purchase date within the UK mainland and Northern Ireland. An extended warranty or Service Contract is available by contacting our sales office.

Damage caused by misuse is chargeable and will invalidate the warranty, as will poor installation, if the machine is not installed in accordance with the installation instructions as detailed in this manual.

This warranty does not affect your statutory rights.

Note:

In all communications relating to warranty, please quote the serial number of the machine concerned. This can be found on a label each side of the machine and on the hopper front when the cover has been removed.

If we can be of further assistance please do not hesitate to contact us:

Sales

Telephone	+44 (0)1989 763131
Fax	+44 (0)1989 768777
Email	sales@haigh.co.uk

Service

Telephone	+44 (0)1989 760230
Fax	+44 (0)1989 768777
Email	service@haigh.co.uk



EC Declaration of Conformity

We The Haigh Engineering Company Limited
of Alton Road,
 Ross-on-Wye
 HR9 5NG
 UK

declare that the following products:

Quattro (s/n 1146A-x-xxxx, 1146B-x-xxxx, 1146C-x-xxxx)

in accordance with the following directives:

2006/42/EC - Machinery Safety Directive
2004/108/EC - Electromagnetic Compatibility
2006/95/EC - Low Voltage Directive
2011/65/EU – Restriction of the Use of Certain Hazardous Substances in
Electrical and Electronic Equipment Directive (RHOS)

comply with the following standards:

BS EN ISO 12100:2010 - Safety of machinery – Risk Assessment
EN61000-6-1:2007 - EMC Immunity
EN61000-6-3:2007 (+A1:2011) - EMC Emission
EN60204-1:2006 (+A1:2009) - Safety of machinery - Electrical

and, by meeting all essential requirements of the directives, are marked with the CE mark.

Signed 
Name Martin Price
Position Healthcare Division Manager
Date 11 November 2016



Operating & Maintenance Manual

Table of Contents

1. Safety Precautions & Procedures
2. Equipment Description, Process and Control
3. Installation & Commissioning
4. Maintenance & Servicing Procedures
5. Part Identification Diagrams
6. Fault Finding & Troubleshooting

1. Safety Precautions & Procedures

Operating & Maintenance Manual

Introduction

This manual provides instructions which must be followed when installing and servicing the machine.



“WARNING – to reduce the risk of injury, user must read instruction manual”

Please note:

- The machine should only be installed by suitably qualified technicians who have read this manual.
- A copy of the manual must always be at hand where the machine or installation is being used. Relevant sections of this manual may be printed from the manual on the CD-ROM that comes with the machine.
- In addition to these general safety instructions you must observe the special safety instructions which are included in other sections of this manual.

Safety Symbols and Instructions

The Hazard Sign



This sign is used in the manual as a general hazard symbol to mark those safety instructions whose non-observance can result in danger to personnel or equipment

The Warning Sign



WARNING, RISK OF ELECTRIC SHOCK TO PERSONNEL

This sign is used as a warning against electric voltage

- Single Phase supply - 230V
- Three Phase supply - 400V

The Safety Sign



This sign is used to denote that appropriate Personal Protection Equipment must be worn.

Instructions Located Directly on the Machine

All instructions located directly on this machine must be observed and be kept completely legible at all times.

Electrical Safety

- Low voltage electrical equipment (less than 1000V) can cause serious or fatal injuries.
- Any person installing or maintaining this equipment should be fully competent to carry out this work.
- Such persons should be familiar with the relevant codes of practice or standards which are applicable to the country of installation.

Preliminary Operating Advice

- This machine is designed to operate on a fully automatic cycle. During this cycle it will only stop if a fault occurs or if it is overloaded.
- If the hopper is overloaded beyond the recommended capacity the internal trip can cause the machine to stop. Continued abuse in this manner will eventually cause motor failure.
- If an emergency occurs, such as a foreign object being in the hopper, the machine should be stopped immediately by switching off the power at the isolator.

Staff Qualifications & Training

- All staff who operate, maintain, inspect or install the machine must be suitably trained and qualified and have the necessary equipment or tools to carry out their tasks safely.
- The person who is responsible for staff supervision should define the exact areas of responsibility and scope of authority for all staff using or maintaining the machine. If a member of staff lacks the necessary knowledge, he or she must receive due training and instruction.
- Any training or instruction that may be required can be provided by the manufacturer or supplier.
- The supervisor must also make sure that the content of this manual is fully understood by the staff concerned.

Dangers Arising from Non-Observance of Safety Instructions

- Danger to personnel and to the machine.
- Danger to the environment through leakage of hazardous substances.
- Loss of all entitlement to redress.

Safety Conscious Working

- In addition to the safety instructions given in this manual, it is essential to follow the national accident prevention directives currently in force and any internal regulations concerning work and safety.
- Duty of care - Your personal safety, the safety of others, of the equipment and the environment is the responsibility of everyone.

Safety Instructions for Maintenance, Inspection & Installation

- Leakages of contaminated material must be discharged in such a way that neither personnel nor the environment are placed at risk. Statutory directives must be observed.
- All possible danger from electric shock must be eliminated (for details see the regulations of the country of authority and your local power supply company).
- Observe equipment warning signs.
- The supervisor must ensure that all maintenance, inspection and installation work is carried out by authorized and qualified skilled staff, who are duly informed about the machine and/or installation after studying the manual thoroughly.
- Work on the machine must only be carried out with the machine stopped and electrical power supply turned off at the isolator switch.
- Pumps or assemblies which convey, or are in contact with, harmful media must be decontaminated.
- All safety devices (Interlocks), must be refitted and be in working order immediately after the work is carried out, and their operations checked.

Arbitrary Modifications & Replacement of Product Parts

- Modifications or changes to the machine are only permissible after consulting with the manufacturer.
- Original spare parts and accessories authorised by the manufacturer contribute to safety.
- If unauthorised parts are used, this will exempt the manufacturer from liability for any consequences caused by the use of those unauthorised parts.

Unacceptable Modes of Operation

- The safe operation of the machine as delivered is guaranteed only if it is used within the manufacturer's guidelines. This machine was designed on the basis of specified conditions of operation contained within the conditions of purchase of the equipment. The specifications listed in the conditions of operation are to be regarded as limit values and must not be exceeded under any circumstances.
- All users should be made aware that, if the equipment is used in a manner not specified by the manufacturer, the protection provided by the equipment may be impaired.

Operating & Maintenance Manual

2. Equipment Description, Process and Control

Operating & Maintenance Manual

Information about Quattro

About The Machine

Quattro consists of an electric motor which drives a pulveriser, with a separate water pump that flushes the hopper and outlet pipe-work.

Water is supplied via mains supply or a storage tank through an inlet solenoid valve. The solenoid valve is operated by the machine's printed circuit board (P.C.B.) which receives a signal from a level switch mounted in the cistern. The water is drawn from the cistern by a separate pump and is discharged via the plumbing system into the machine. A measured quantity of deodoriser is fed into the plumbing towards the end of the cycle.

The internal surfaces of the lid and hopper are automatically washed down by the spray from a vent centrally mounted on the underside of the lid.

Switching on the wall isolator actuates the microprocessor which performs a safety monitoring assessment of the condition of the machine before the green ready to run light illuminates. The machine is now ready to start a cycle of operation.

The electrical safety system is continuously monitored by the internal microprocessor.

If a problem occurs, cycle termination devices end the cycle of operation and the respective warning or fault light will illuminate. For operation refer to the indicator panel.

This machine is a Water Regulations Advisory Scheme (WRAS), approved product with protection from contamination to the water supply provided by an Air gap to EN 13077, Family A, Type B.

Maceration cycle: 94 seconds.

The Pulveriser

The pulveriser consists of an impeller rotating at high speed within a toothed cutter ring which forms the lower part of the stainless steel hopper assembly.

The impeller is fitted with two sweep blades which pulp the bedpans and urine bottles before the pulp passes on through the disposer.

- Dispose of pulp products **only** e.g. bedpans and urine bottles.
- The machine is not designed to dispose of dressings, swabs, gloves etc.
- **THESE WILL JAM THE MACHINE**

Should an unsuitable object have been inadvertently placed in the machine and the impeller become jammed, the motor overload trip will operate to stop the machine and the red fault light will illuminate.



Always isolate the machine from mains electrical supply before servicing.

Remove the object and ensure the impeller is free to rotate. The overload trip device within the control box will automatically reset. Close and latch the lid.

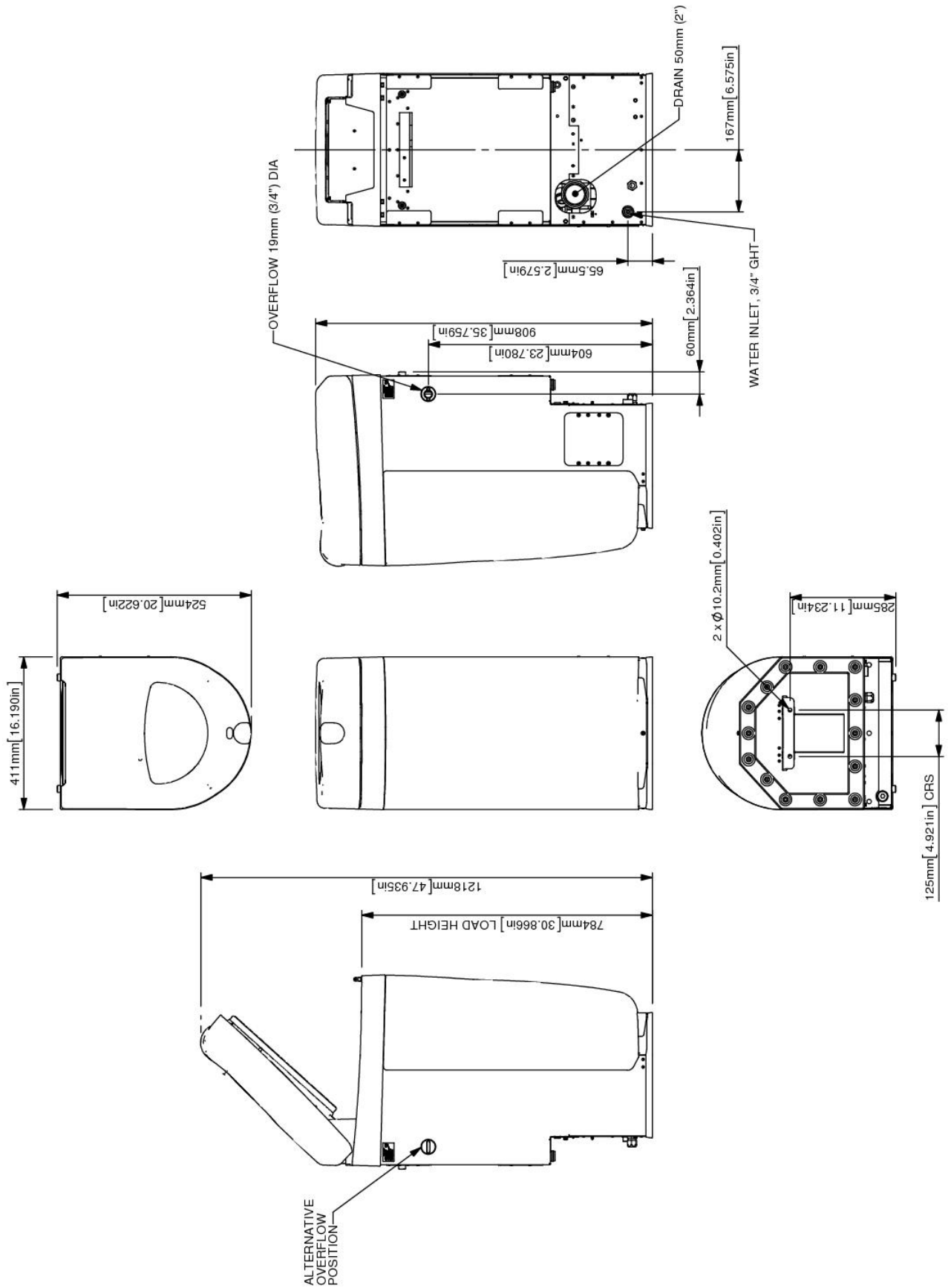

Installation Diagram





Specification

Feature	Detail
Isolator	For single and three phase machines 20 amp Isolator to I.E.C. standards.
Water Pump	Self-primed from the cistern. Electric centrifugal pump.
Maximum Loading Pulp Products Only	Maximum Four. Disposable bedpan, urine bottle. Any combination of disposable bedpans or urine bottles 2 Wash bowls maximum
Pipework Connections	Mains inlet ¾" B.S.P. female connection.
	Waste Drain Outlet 50mm (2" B.S.P.) Multifit P Trap
Mains Water Inlet Flow Rate	Required flow rate. Minimum 5.5l/m Water regulated to 9 lpm maximum.
Cistern	13 Litres Capacity. Inlet protected by an 'EN 13077, Family A, Type B'
Water Consumption	Cycle 1 = 17ltrs Cycle 2 = 18.5ltrs Cycle 3 = 23ltrs
Cistern Overflow Indicator	Never connect the overflow indicator stub to the drain. Ensure any discharge is Visible
Direction Of Rotation For Macerator Motor	Single phase machines are supplied with the correct rotation. Three phase machines must be checked. - Clockwise direction only when looking into the hopper. Refer to Commissioning section.
Weight Of Machine	Machine only. 65 kg. Machine on pallet. 70 kg.
Mounting	Floor 10mm dia securing bolts
Temperature Operating Range	+5 to +40°C
Humidity Operating Range	50-80% RH
Noise levels	The A-weighted emission sound level, LpA, produced by Quattro does not exceed 70 dB(A).







All installations must comply with statutory regulations, local water by-laws and relevant codes of practice of the country of installation. Responsibility for this must rest with the installer. The company make every effort to comply with national requirements/standards.

Operating Your Machine

LCD Panel Chart

Normal Operation			
QUATTRO ✓			Standby (sleep)
		✓	Ready / Standby (awake)
		✓	Lid opening initiated, display flashes
		✓	Running
		✓	Running, extended cycle

Identification of the Symbols and Indicator Lights

	Indicator light Green	Machine healthy
	Indicator light Amber	Machine warning of attention required
	Indicator light Red	Machine indicating fault. Call for service engineer. Please Quote Fault Code when calling (See Page 50)
	Water Filling	Rising until the tank is full. Illuminated on low water condition, after 180 seconds fault light also illuminates.
	Drain Block Indicator	Illuminated during a drain block cycle. On release, if water and pulp are still in the hopper covering the impeller, call the Service Engineer.
	Low deodoriser	Illuminated when deodoriser requires changing.

See Chapter 6 for troubleshooting for the above indicators

How to Operate Quattro

Refer to the indicator panel shown on the facing page.

With the green indicator light on the open button illuminated... **Open, Load, Close**



1. **Open** the lid by pressing the blue Lid Release button.
2. **Load** the machine:

MAXIMUM load for this machine:

Disposable bedpans

Four

Urine bottles

Four

Any combination of products above

Four

Wash bowls

Two



DO NOT exceeded this maximum loading.

3. **Close** the lid, the lid will lock and the machine will start its fully automatic cycle.

Once the cycle has finished the lid will be able to be opened for the next operation.

Hands Free Opening

When fitted with an optional extra Foot Pedal Hands Free Opening Kit, the Quattro lid can easily be opened by operating the low profile foot bellow (See Image Below).



Operating Advice



- Operate Quattro immediately after every loading.
- **Wash hands after every loading.**
- Never use a chemical reaction substance to clear a drain block situation in the disposer, damage to the seals will result.
- To reduce the possibility of the machine jamming, do not place the bedpans inside each other when putting them in the hopper.
- If electrical power to the machine fails during an operation cycle, the interlock remains engaged. The interlock releases once power is restored to the machine.



- **Do not attempt to force the lid open**

Once Daily

- Run the machine under “no load” conditions to clear any residue.

Fault Light

- Call the service engineer if the light is illuminated red (Please Quote Fault Code – See Page 50)
- Do not attempt any servicing yourself.

Replace Haigh Internal MaciFresh™ Kit

1



2



3



4



5



6



7



8



3. Installation & Commissioning

Installing Quattro



Please read and familiarise yourself with the technical points contained in this section of the manual before installing this machine.

Installation Requirements



Quattro requires the following services for installation. Please refer to specification page:

1. Cold water supply.
2. Waste outlet connection - From internal 'P' trap to mains sewage only.
3. Overflow - Ensure indicator pipe discharge is visible.
4. Electrical Connection.

Installation Planning



Consider location and availability of power, water supply and drainage.

Note:

- Sufficient space should be allowed for the removal of the front panel and to service the machine.
- The machine must be level in both directions.
- Never allow the pump to run in a dry condition.

Cold Water Supply



Quattro is designed to operate on a minimum water flow rate of 5.5 lpm. The supply into the cistern is regulated to a maximum of 9 lpm via a constant flow valve located in the inlet solenoid.

To establish the flow rate the initial fill of the machine is timed:

Initial Fill Time	Flow Rate
87 seconds	9 lpm
142 seconds	5.5 lpm



The flow regulator may not be removed to improve the flow as this will invalidate the machines WRAS Approval. For advice on low flow installations please contact your service representative, contact details provided within this manual.



- Break tank supply is permissible providing a minimum flow rate of 5.5 lpm is available at the machine connection.
- Ensure that the supply line to the machine is at no point less than 15mm, larger if the available head is very low.
- Ensure that the supply cannot be starved by other fittings.
- Ensure that the machine connection complies with statutory regulations, local water authority bylaws and relevant codes of practice.



• **A dedicated isolation valve (not supplied), must be fitted in the cold water supply pipework. It should be placed close to the machine so that it is readily accessible during maintenance or servicing.**

- A feed hose is required for connecting the machine to the water supply.
- The cistern is fitted to this machine and provided with an 'EN 13077, Family A, Type B' to prevent back syphon of contaminated water.



• **Under no circumstances may the cistern be bypassed.**

Waste Outlet Connection



Quattro is designed to be installed to 50mm pipework with a fall of 1:25 or sufficient to maintain a self-cleansing velocity.



We recommend that the maximum total length of pipework before entering the 100mm vertical soil stack is 3m with one swept bend. If an additional swept bend is introduced then the maximum length would reduce to 2.5m.



- Minimum size of waste pipe 50mm.
- **Connect the machine to the drain using the minimum number of long radius/swept bends. Use long radius or 'swept' bends - never short bends or 90° elbows.**



- When a machine is installed on an existing drain then check that there is no calcium build-up as this reduces the efficiency of the drain and may lead to blockages.
- Provide easy access for rodding.
- The machine is fitted with a 50mm 'P' trap inside the cabinet terminating in a compression fitting suitable for a 50mm pipe stub. The outlet is for rear connection. Fitting a slow bend will allow for alternative connections through the floor / to the right / and to the left.
- **Never connect waste outlet to a septic tank.**
- Machine waste must be run separately to a 100mm vertical soil stack.
- Ensure the waste takes the shortest route to the soil stack.
- Ensure a clean run inside pipework - no burrs or reducing shoulders.
- Support plastic pipework adequately on runs to prevent sagging. Remember ceiling voids can get very warm.
- Avoid running the drain line near or across hot water pipes.
- A straight pipe run is preferable but if necessary any change of direction must be kept to a minimum, with an overall length run of two metres. However, if you need to exceed this length please contact Haigh Engineering for further assistance.



Overflow

The overflow indicator pipe from the integral cistern needs to be run to a suitable position. A 1" nominal push in socket is fitted to the cistern for customer connection.



- Ensure that discharge from the overflow is visible.
- **Do not connect the overflow directly into the soil drain. A tundish device may be used.**

Electrical Information

Quattro is supplied for use on either single phase or three phase power supplies.

Refer to the rating label details on the top of the electrical connection cover of the machine.



- **All electrical installations comply with current I.E.E. regulations.**
- Appropriate I.E.C. approved cables have been used.
- The appliance is connected to a protective earth connection via the earth terminal and identified by the earthing label.



- **Isolator (customer supply) to be mounted adjacent to appliance.**
- A 2 metre cable flying lead is supplied ready fitted to the machine for connection to the customer's isolator.
- Mains supplies always to be protected by I.E.C. approved circuit breakers or fuses.
- The thermal relay overload device in the motor circuit should always be set for a value corresponding to the rated current of the motor. The overload is pre-set before leaving the factory in the automatic reset mode.

Circuit Breakers / Fusing



The following recommendations for electrical protection apply:

	Single Phase	Three Phase
Rating	Refer to Rating Label	
MCB to ESEN 60898 Type D	6 Amp	4 Amp
Fuse to BS 88 HRC	13 Amp	6 Amp
Connection Cable	1.5mm ²	

Existing Installation

Where an isolator and a lead is already present from a previous installation, fit a junction box (not supplied) to the wall and connect the lead and the 2 metre flying lead of the machine into the junction box.



Ensure that the circuit breaker or fusing complies with the preceding table.

Storage (Customer)

If the machine is not to be installed immediately, it should be stored in the carton in which it has been transported, in a clean, dry place which is free from vibration.

Undo the carton, lift the lid to periodically rotate the impeller by hand to prevent the mechanical seal seizing. Re-seal the carton after doing this.



Industrial gloves must be worn when working on or rotating the impeller by hand.

Removing From Storage (Customer)

If the machine has been stored, ensure that the impeller boss is free to rotate. The mechanical seal may have seized if it has not been revolved frequently or through water drying out. Result: Motor will not start, or does start and damages seal faces.

To free the mechanical seal:

- Remove the impeller and part the seal faces, lubricate with clean water only.
- A new mechanical seal will be required if faces are damaged as the seal will leak.

Note:



- **Industrial gloves must be worn when working on or rotating the impeller by hand.**
- Never put tools etc. on the cabinet top, these could damage the surface.
- Never allow the pump to run in a dry condition.

Unpacking the Machine

1. Remove the carton and any packing materials.
2. Remove the front panel screw, hold both sides of the front panel at the bottom and pull to release it and access the interior.
3. Remove the electrical control box to access the central fixing down bolt.
4. Remove the central fixing down bolt.
5. Remove the machine from the pallet.
6. Remove the bolts that secure the floor locating bracket to the pallet. The floor locating bracket will be used to fix the machine to the floor and is positioned by using the template (supplied).
7. The machine is now ready for installation.

Installation Procedure



Having read and understood the preceding contents of this chapter:

1. **Position the floor template** - Place the template in the desired position on the floor.



Ensure that there is sufficient clearance behind the machine for cleaning requirements.



CAUTION: Before drilling, check & position the template to ensure that the holes do not affect under floor heating or other services.

2. **Drill holes** - Place the floor locating bracket in the position indicated on the template and drill the fixing holes. **Ensure the template is not moved while drilling.**
3. **Remove template** - Take the template away and replace the floor locating bracket.
4. **Secure the bracket** - Using the desired floor fixing fasteners (not supplied) bolt the floor locating bracket to the floor. Ensure the floor locating bracket is fitted the correct way round as indicated on the template. The machine should be rigid with compression on the rubber mounting keeping the machine secure.
5. **Position** - Lift the rear of the machine centrally over the floor locating bracket. Slide the machine forward on the runners underneath, until the floor locating bracket locates in the two guide slots in the runners.
6. **Secure the machine and connect services:**
 - Replace the mounting base bolt under the motor to secure the machine in position.
 - Make the waste connection from the internal 'P' trap (to mains sewage only). Ensure that connecting pipe is cut square and deburred before fitting to prevent the waste snagging within the pipework and restricting the flow.
 - The cistern overflow indicator pipe discharge should remain visible to indicate an overflow condition. A tundish device is available as an optional extra to direct overflow water to a drain.
 - Connect the mains cold water inlet supply. Open the inlet isolating valve.
 - Connect the flying lead supplied ready fitted to the machine, to the installation isolator. Note advice on electrical information page.
 - Turn on the electrical supply. The inlet solenoid valve opens to admit water to the cistern.
 - Continue with commissioning the machine. Ensure the rotational direction of the machine is correct. A direction of rotation label with cord tail is attached to the impeller in the hopper. The cord trail must indicate the trail towards the tick. This is only needed for the three phase machine.
7. **Fit front panel** - Refit the front panel. Secure with the front panel screw.

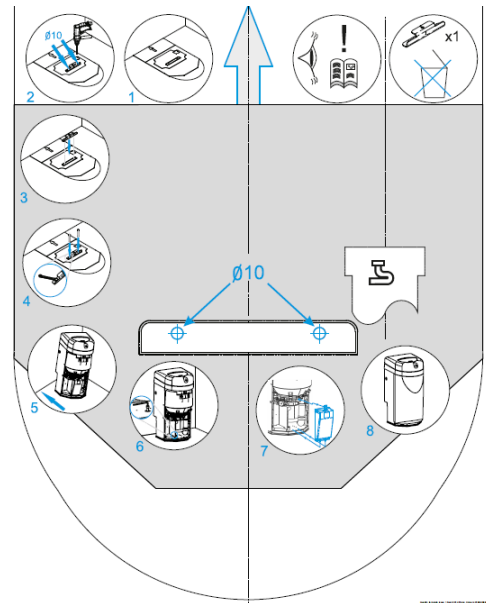

Commissioning

Commissioning must be carried out by person(s) suitably qualified and authorised to carry out mechanical and electrical maintenance.



Check that the machine is isolated from the electrical power supply. If not, isolate.

Mechanical checks

- Ensure the machine has been securely bolted down.
- Clean off any accumulated surface dust and dirt.
- Check inside the machine & surrounding area for tools, fasteners, rubbish or other foreign objects and remove them accordingly. Most problems which arise during the first hours of operation are caused by such matter.
- Check that the water is connected & turned on.
- Check that the drain is connected.

Electrical checks

- Check that the electrical connection is made in accordance with the previous section.

Impeller direction of rotation - three phase machines only

The rotational direction of a single phase machine is correct when dispatched, but a three phase motor can be wired correctly when testing at the factory but incorrectly when the machine is installed. Pulp products remaining in the hopper is the result of incorrect rotation.

- Open the lid & look into the hopper to see the rotation indicator label and cord that is affixed to the impeller.
- Close the lid & start the machine.
- Open the lid after the cycle is completed and observe the direction of the resulting cord trail.
- If the direction is towards the 'X' the motor is revolving in the wrong direction. **If so reverse the phases at the connection to the isolator.**

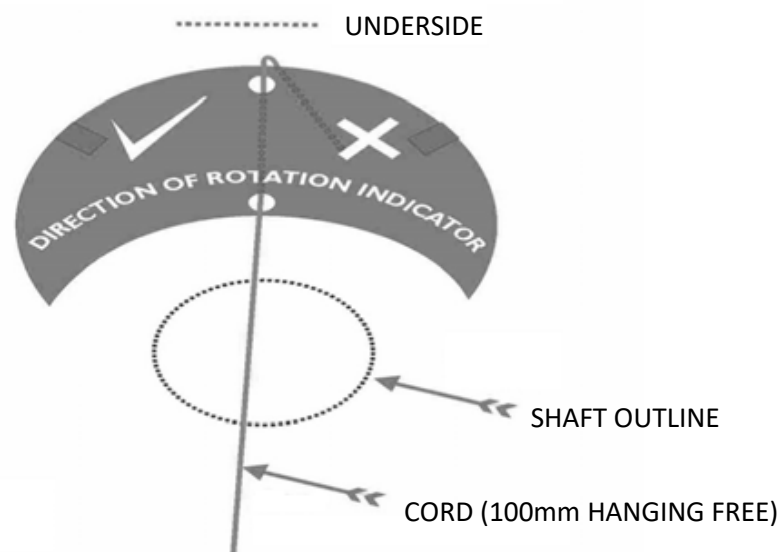

4. Maintenance & Servicing Procedures

Routine Maintenance



Electrically isolate the machine before undertaking any routine maintenance.



Industrial gloves must be worn when working on or rotating the impeller by hand.

Daily

- Run the machine under “no load” conditions to clear any residue.

Monthly

- Lid spray- remove any scale and replace.
- Check that the lid micro-switch and solenoid latch operate.
- Check for leakage from the pulveriser and water pump seals.

Quarterly

Water Supply and Drainage

- Check for leakage from the pulveriser or water pump seals.
- Check for leaks cold water supply pipe-work.
- Check that the machine is draining correctly.
- Check that the drain block pressure switch tube is clear of water.
- Check and clean solenoid filter or replace.

Mechanical

- Check wear on the hopper cutter ring/impeller.
- Check that the impeller is rotating freely and for absence of vibration.
- Inspect and tighten nuts and bolts as necessary.
- Check the condition of the lid/hopper seal, and that the lid opening gas spring operates correctly.
- Check the lid latch arrangement. Turn isolator off during an empty cycle to simulate a power loss and ensure that the solenoid has secured the latch in the locked position.

Electrical

- Check contactor is operating correctly in control gear.
- Check overload units operating and set correctly.
- Check lid positive break interlock switch operates correctly.
- Check electrical connections in control gear and motor terminal box are secure.
- Low water sensor and drain/hopper block pressure switch operate.

Functionally test the machine.

Cleaning Recommendations



Electrically isolate the machine before cleaning.



Never use a wet solution to clean the indicator panel.

Daily

- All exterior panels to be wiped over with normal cleaning solution for worktops etc. (soapy water) and then dried.
- The best results are obtained by opening the lid which allows full access to the seating and the lid seal.
- All internal surfaces are automatically cleaned by the machine. **Failure to do so must be investigated.**

Weekly (as required)

- The lid seating area should be scrubbed with a brush, wiped and the neoprene seal washed with the same cleaning solution.

Lubrication

The machine is designed for minimum maintenance.

- The clip bushes used in this machine must **not** be lubricated.
- Apply anti-seize compound if indicated.
- The motor is fitted with sealed for life bearings.
- The mechanical seal face must be perfectly clean.
- Use only clean water to lubricate the seal face.

Ordering Spares

Spares are identified in Chapter 6 of this manual and can be ordered from Haigh Engineering.

Telephone +44 (0)1989 760230
Fax +44 (0)1989 768777
Email service@haigh.co.uk

Please quote the following information

- Your contact details
- The machine serial number
- The part number required
- The full part description
- The quantity of each part required
- The invoice address
- The delivery address

Failure to state the above details may cause delay in the delivery and accuracy of the parts required.

If required a kit containing recommended spare parts for this machine is available from the contact details above.

5. Part Identification Diagrams

Servicing Quattro



Ensure appropriate protective equipment is worn



ALWAYS isolate the machine from mains electrical supply before servicing

Isolate the water inlet to the pump at the service valve by turning the isolation screw 90°.

Reverse to vertical on completion.



Denotes assembly step

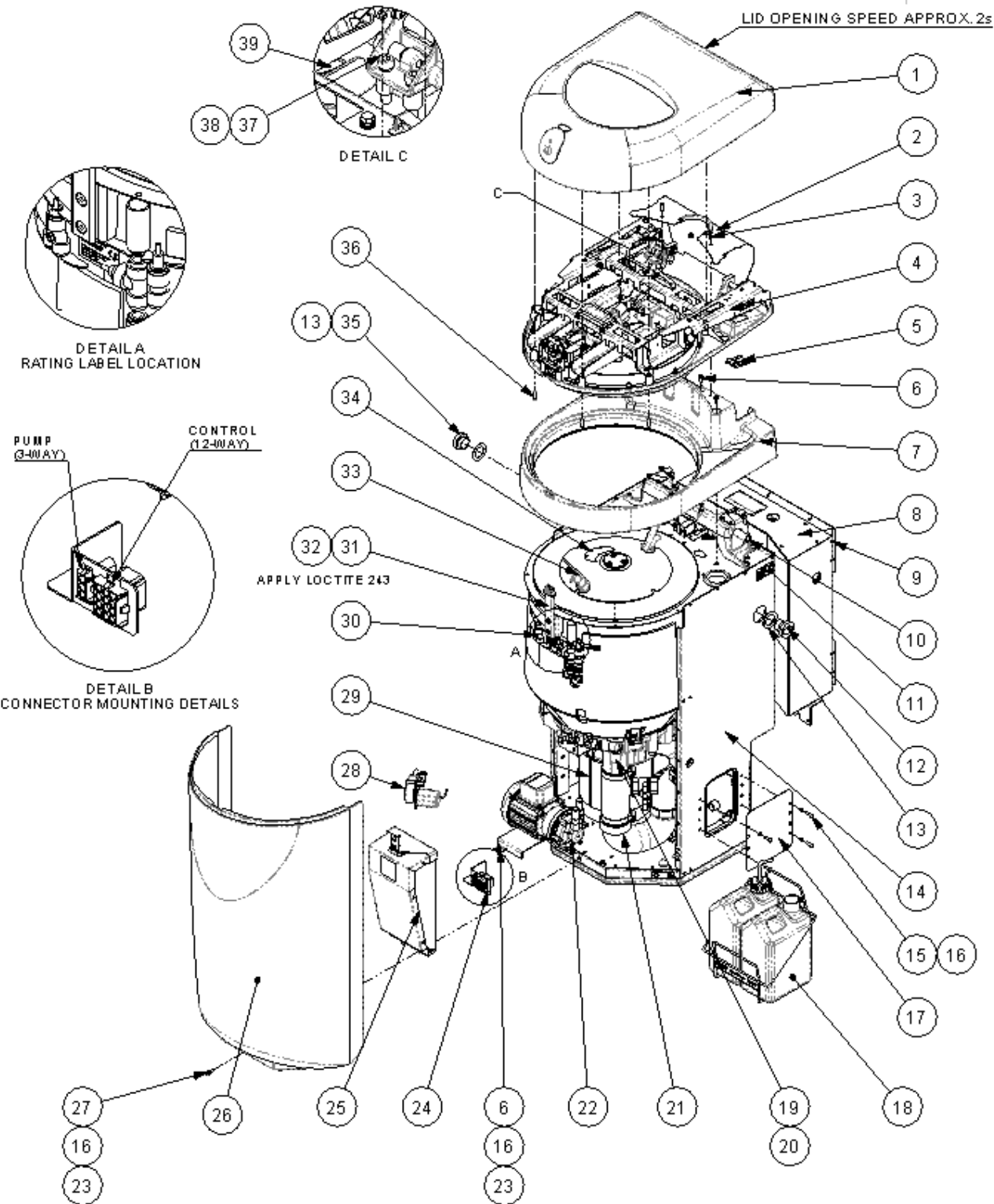

General Assembly

Item	Part No	Description	Qty
1	902-111570	Top Cover Assembly	1
2	901-111851	Rear Cover Plate Assy	1
3	901-107162	Screw M5 X 16 Plastite	4
4	903-111569	Lid Assy	1
5	901-112016	Spring Aperture Cover	1
6	722-006178	Screw M5 X 12 Sckt Cap	6
7	901-111591	Cabinet Top & Seal Assembly	1
8	901-111580	Cistern And Deadsheet	1
9	711-006017	Pop Rivet 3 Dia	11
10	901-111694	Quattro Inlet Plumbing	1
11	90X-112118	Quattro Rating / Serial No Label	3
12	901-111512	Overflow Fitting	1
13	901-111654	3/4" Sealing Washer	2
14	903-110873	Frame & Top Plate Assy	1
15	701-006177	Screw M5 X 16 Sckt Button Hd	4
16	701-006229	Washer 5mm Spring	6
17	901-111224	Service Hole Cover	1
18	901-112566	External Macifresh kit	1
19	901-111567	Pulveriser Head Assembly	1
20	901-110919	Hopper/Head Seal	1
21	901-110942	Drain Outlet Assy	1
22	901-111848*	Pump Assy*	1
	901-100226	Pump	
23	705-006218	Washer 5mm Plain	2
24	90X-112570	Connector Support Bracket	1
25	901-111503	Single Phase Ctrl Enclosure Assy	1
	902-111503	Three Phase Ctrl Enclosure Assy	
26	901-111581	Front Cover Assembly	1
27	707-006120	Screw M5 x 16 Pozi	1
28	901-111812	Deodoriser Pump	1
29	901-111566	Single Phase Motor Assy	1
	902-111566	Three Phase Motor Assy	
30	901-111598	Plumbing Assembly	1
31	901-111600	Striker Assembly	1
32	705-006188	Screw M6 X 16 Sckt Csk	2
33	901-111576	Impeller & Hub Cap Assembly	1
34	900-028063	Label – Rotating Indicator * Three Phase <u>Only</u>	1
35	902-111512	Overflow Fitting	1
36	902-107162	Screw M5 X 20 Plastite	6
37	733-006110	Screw M6 X 30 Sckt Cap Tufloc	6
38	703-006229	Washer 6mm Spring	6
39	902-112016	Spring Aperture Cover	1

*Denotes an assembly of parts

General Assembly Parts List

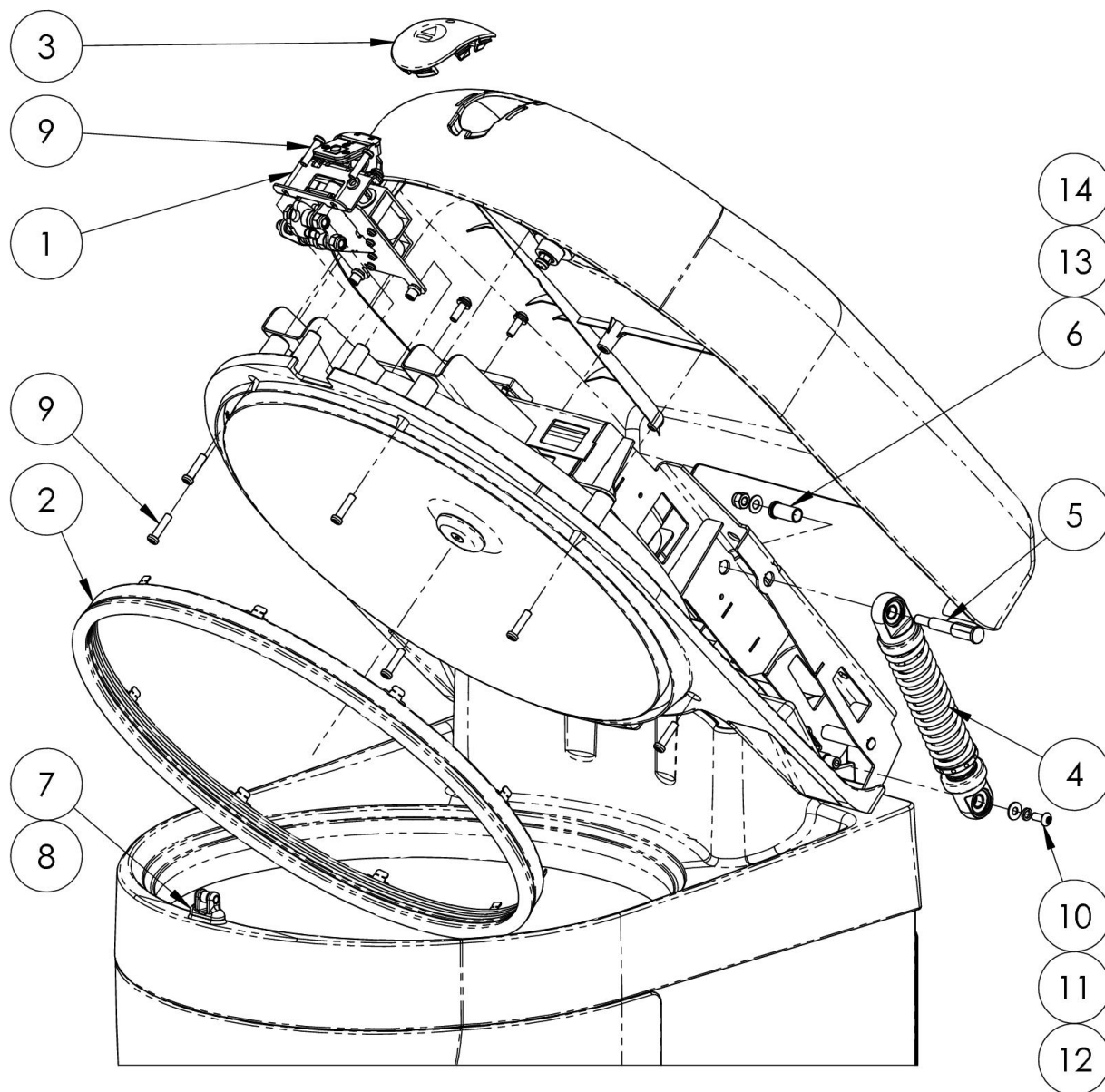

Item	Part No	Description	Qty
1	901-111199	Latch Assembly	1
2	902-111594	Lid Seal	1
3	901-111409	Release Button	1
4	902-111488	Spring Assembly	2
5	901-111522	Hinge Pin	2
6	901-111523	Hinge Boss	2
7	901-111600	Striker Assembly	1
8	901-111421	Striker Seal (included with Striker Assembly)	1
9	901-107162	Screw	8
10		Screw M5x12 Button Hex Sckt	2
11		Washer M5 Spring	2
12		Washer M5 Plain	2
13		Washer M6 Plain	2
14		Nut M6 Nyloc	2

Lid Maintenance

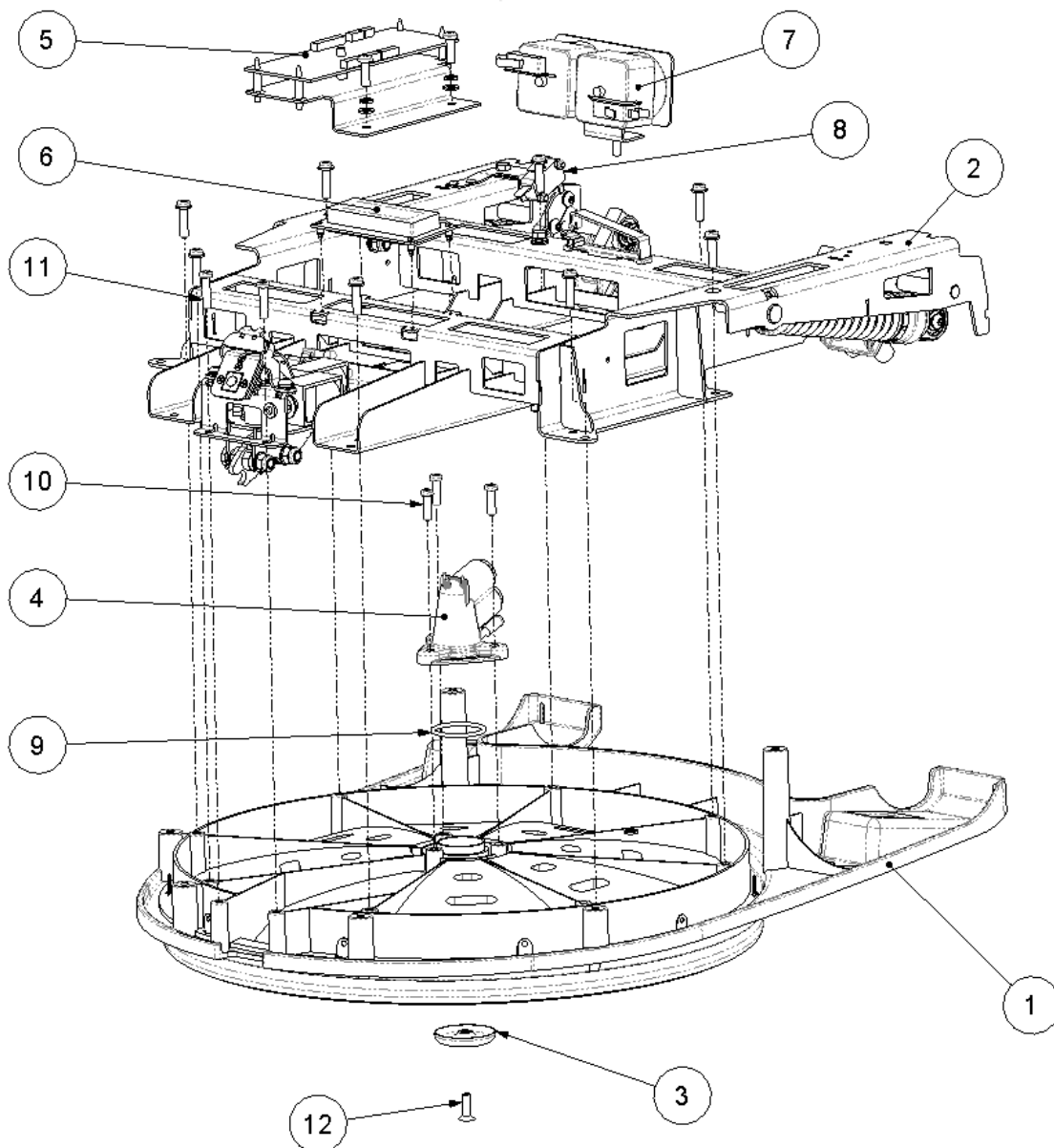

Item	Part No	Description	Qty
1	901-110878	Lid Assembly	1
2	901-111596	Lid Support (c/w Hinge Brackets and Spring Assemblies)	1
3	900-013486	Spray Vent	1
4	901-111288	Spray Inlet	1
5	901-111593	PCB	1
6	901-111571	LCD	1
7	905-003571	Pressure Switch	1
8	900-003940	Switch	1
9	997-051206	O Ring	1
10	901-107162	Screw M5x16 Pozi Pan	3
11	902-107162	Screw M5x20 Pozi Pan	10
12	900-013522	Screw	1

Lid Assembly

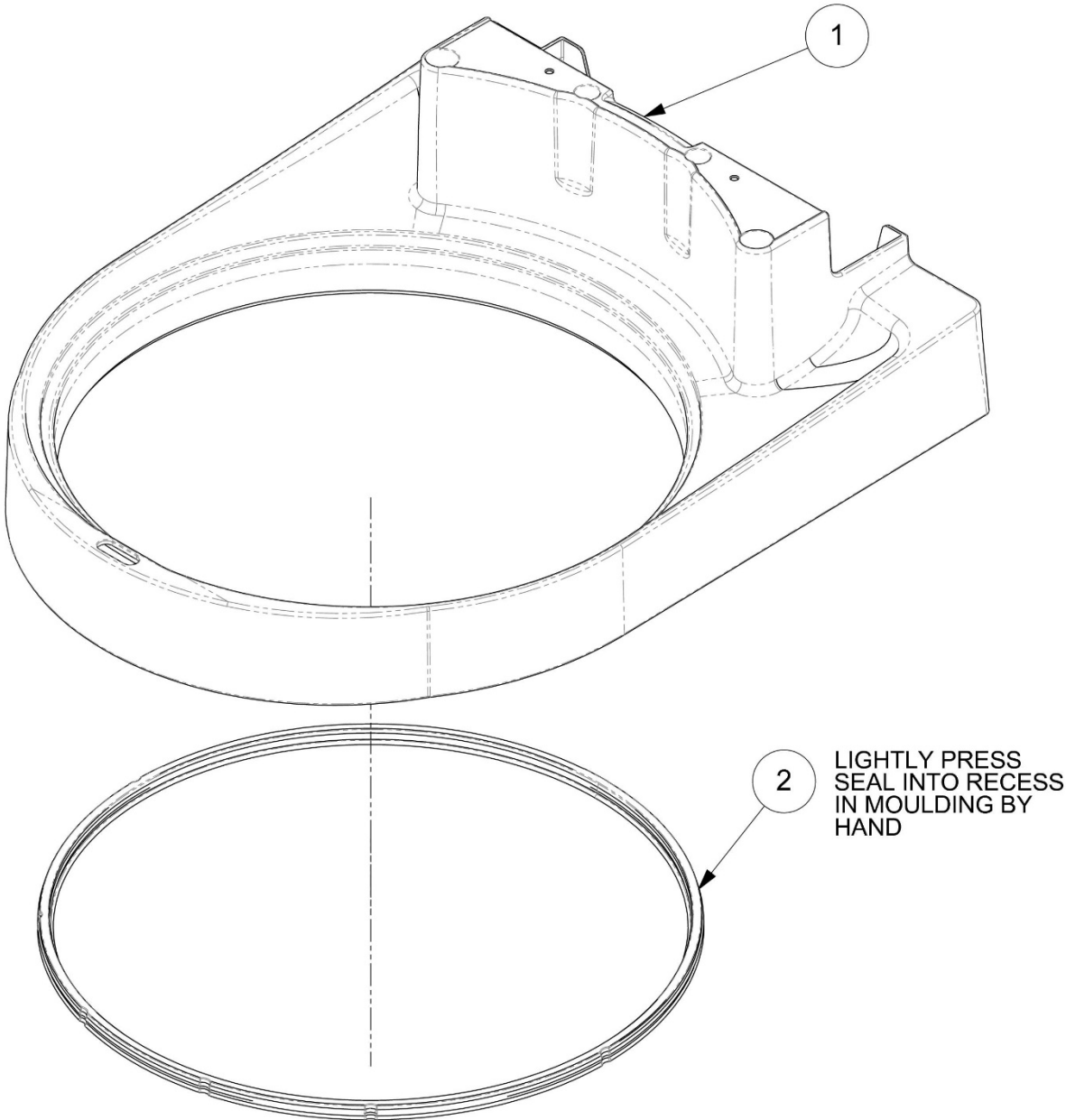

Item	Part No	Description	Qty
1	902-110877	Cabinet Top	1
2	901-111006	Hopper / Top Seal	1

Cabinet Top Assembly

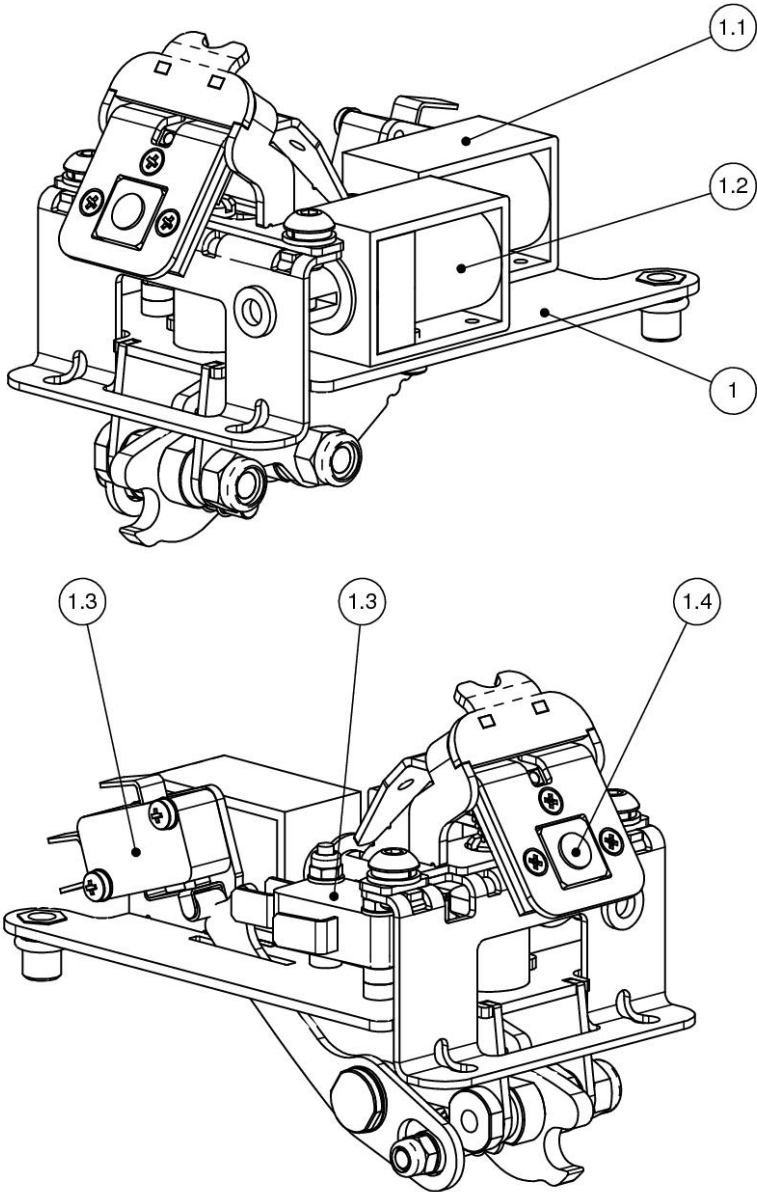

Item	Part No	Description	Qty
1	901-111199	Latch Assembly	1
1.1	902-107552	Solenoid	1
1.2	901-030234	Solenoid	1
1.3	900-030183	Micro Switch	2
1.4	901-111880	Switch PCB	1

Latch Assembly

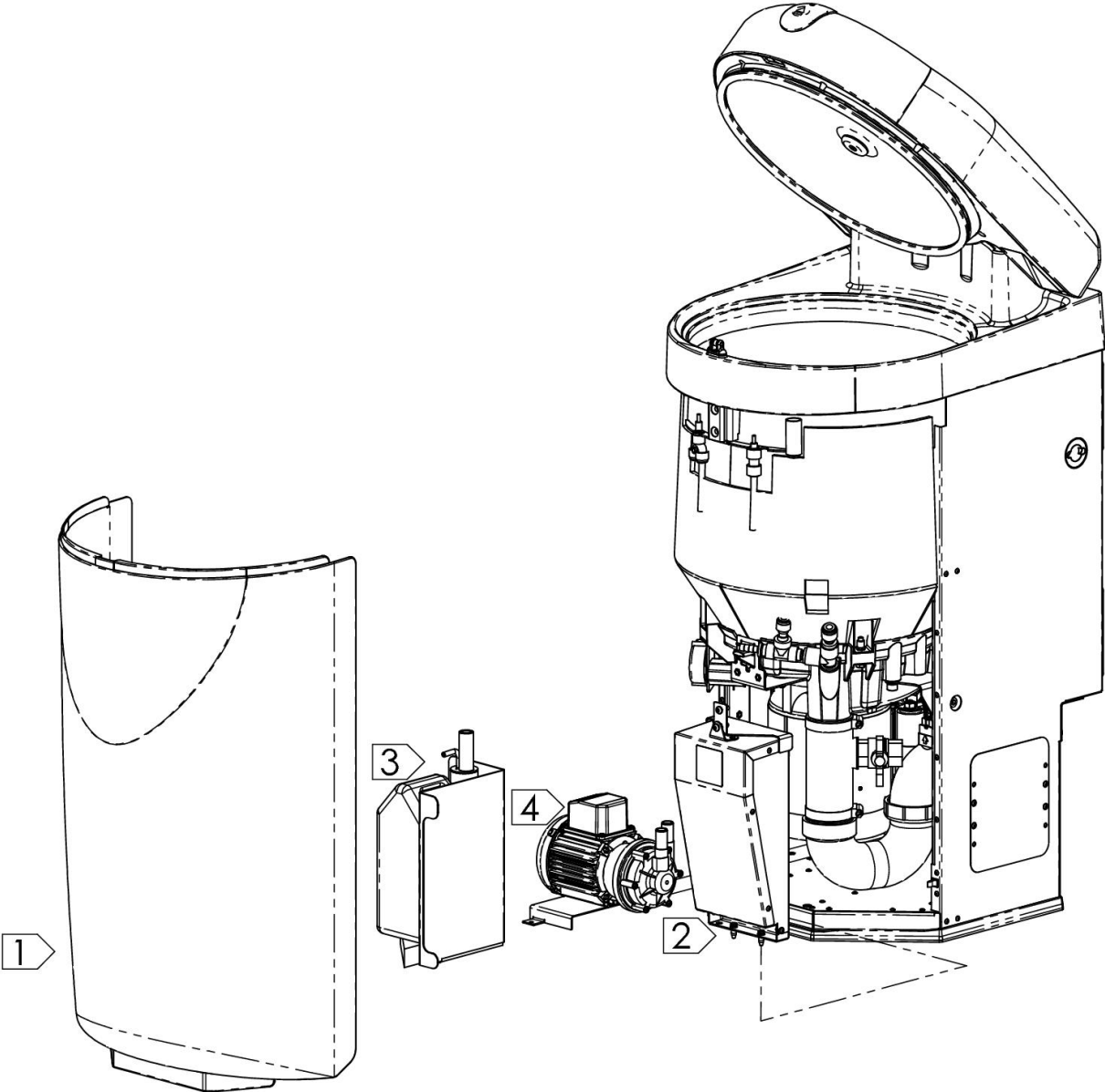

Main Pump & Deodoriser Pump Removal Diagram

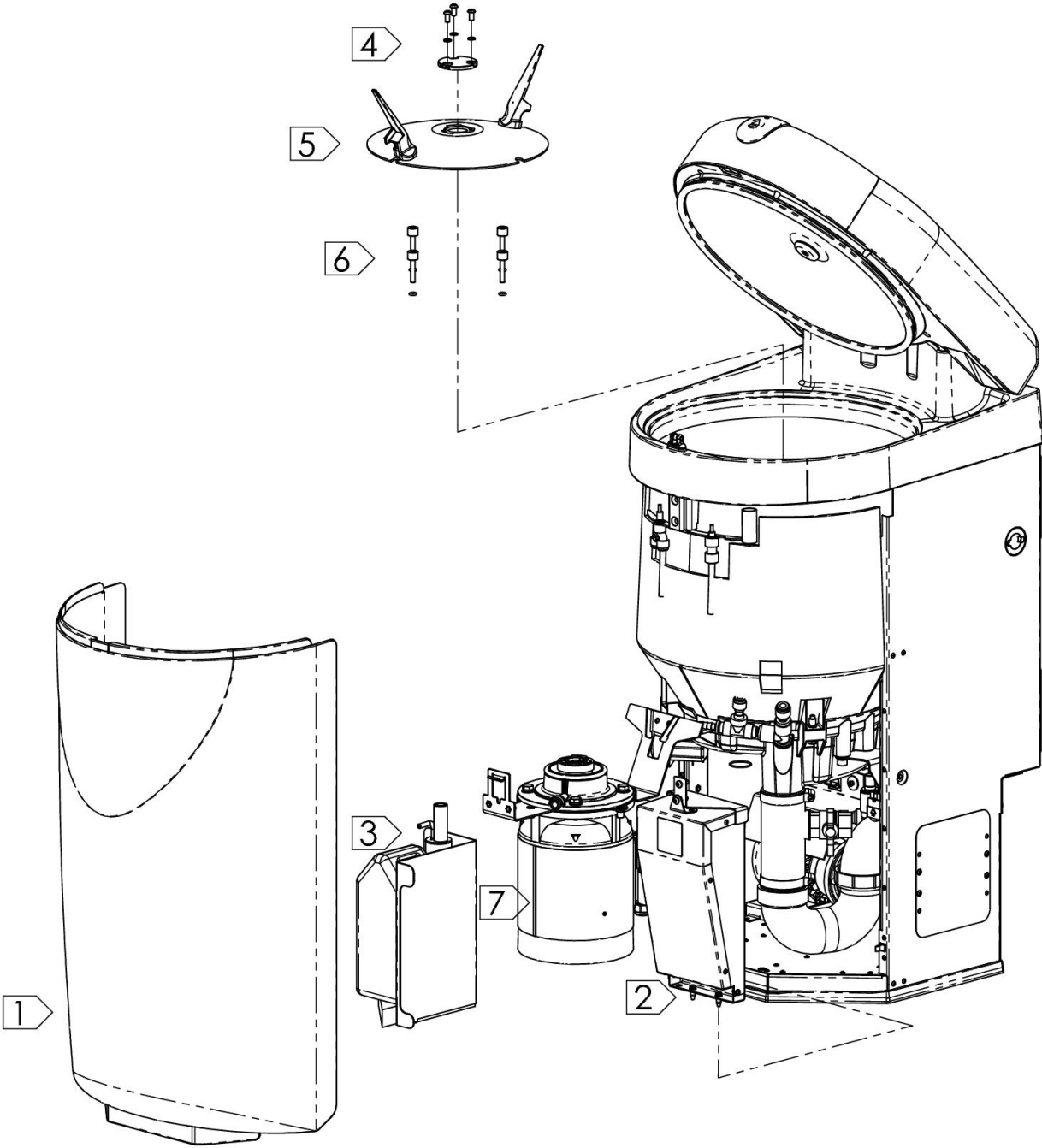

Mechanical Assembly Removal

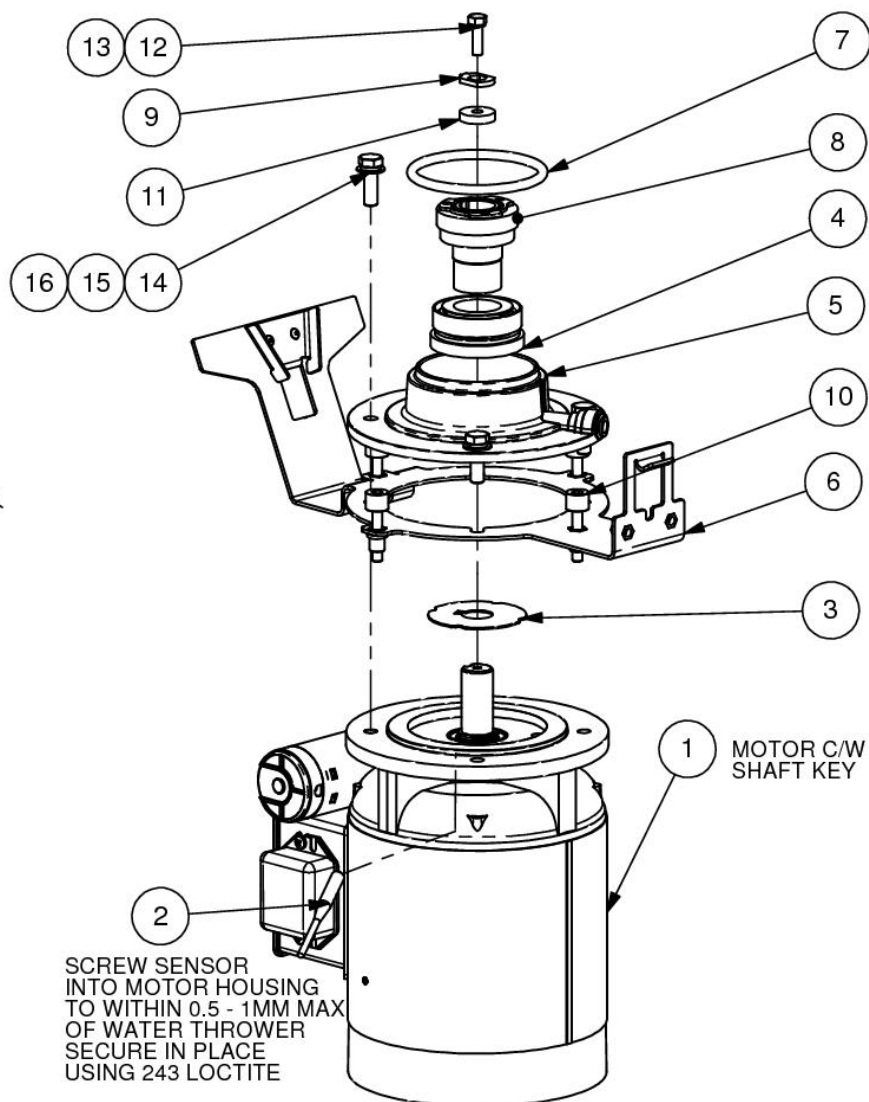

Item	Part No	Description	Qty
1	907-014614	Motor 230V-1-50Hz	1
	903-014615	Motor 400V-3-50Hz	1
2	901-111578	Speed Sensor	1
3	902-013924	Water Thrower	1
4	901-013926	Mechanical Seal	1
5	901-111573	Seal Housing	1
6	901-111266	Motor Hinge Plate Assy	1
7	955-051206	O Ring	1
8	901-013921	Impeller Hub	1
9	901-013841	Lock Washer	1
10	901-111568	Sealed Screw Assy	4
11	901-013922	Hub Washer	1
12	703-006229	Washer 6mm Spring	1
13	761-006110	Screw M6x20 Hex Hd	1
14	709-006218	Washer 8mm Plain	4
15	704-006229	Washer 8mm Spring	4
16	728-006118	Screw M8x25 Hex Hd	4

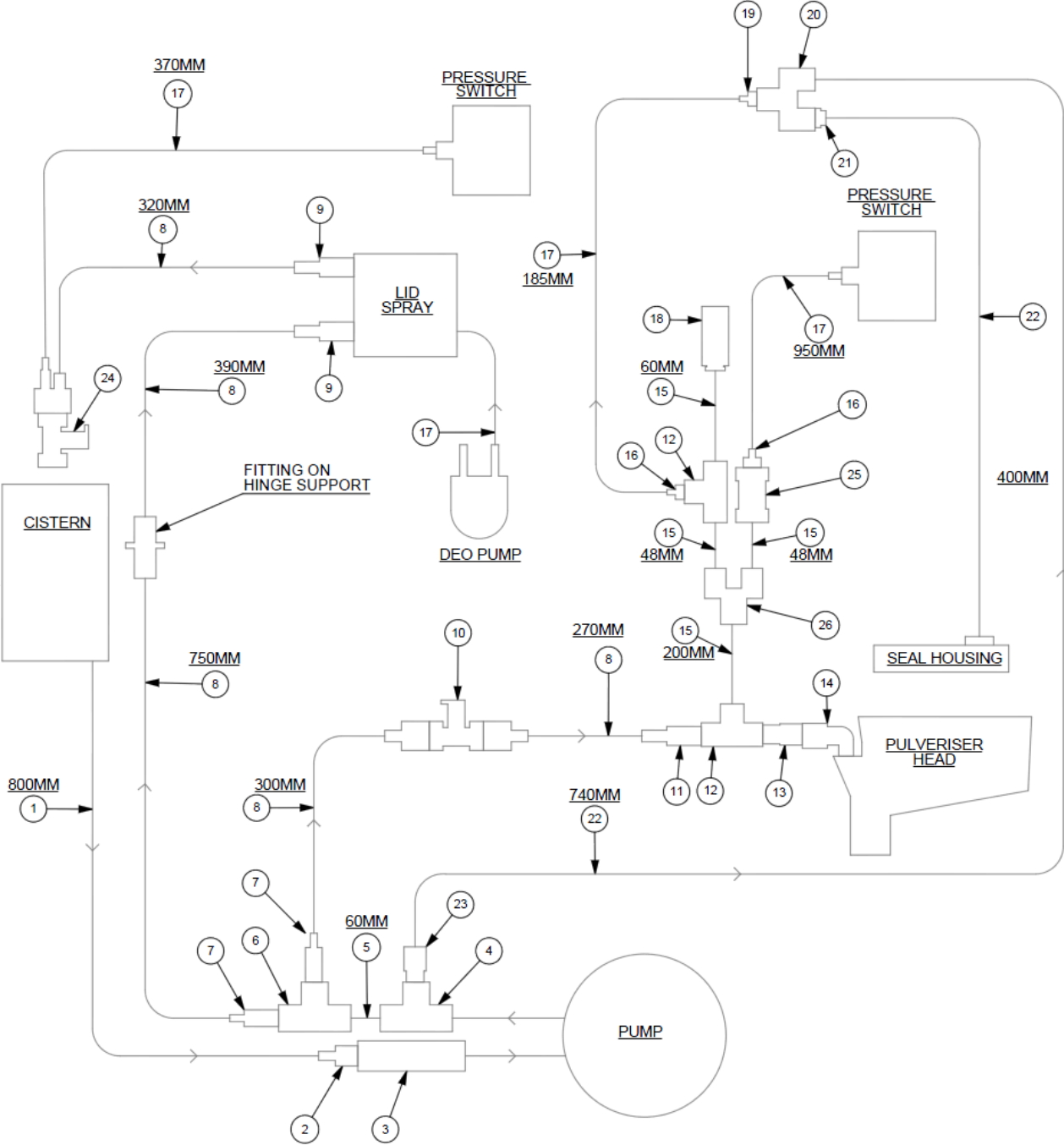

Plumbing Diagram

Operating & Maintenance Manual

ITEM	PART No	DESCRIPTION	Qty
1	604-000131	Ø18mm X Ø13mm PVC Braided Hose RPVC12	800mm
2	904-111546	Hose Stub	1
3	901-013998	Service Valve JG 15SV	1
4	901-013958	Reducing T JG PEM3015AW 15-15-10	1
5	624-000139	15mm John Guest LLDPE Tube	60mm
6	900-016938	15mm Equal Tee	1
7	905-111546	Hose Stub	2
8	627-000139	Ø13.5mm X Ø8mm Reinforced PVC Braided Hose	2050mm
9	901-111546	Hose Stub	2
10	901-111631	Drain Flush Solenoid Assembly (BLUE Identifier)	1
11	901-103002	10mm Tube To 8mm Hose Stem JG PM251008E	1
12	901-101313	Tee 10 X 10 X 10 JG PM0210E	1
13	907-111546	Hose Stub	1
14	900-013608	Stem Elbow 12 X 12 JG PM022121E	1
15	625-000139	Ø10mm X Ø8mm Flexible Nylon Tube	250mm
16	903-013527	Adaptor	2
17	608-000131	Tube 3id X 6od Clear PVC	2050mm
18	901-111840	Vent Valve	1
19	902-013527	Adaptor	1
20	901-013613	8mm Divider JG RM2308E	1
21	901-111562	Seal Housing Restrictor	1
22	628-000139	Tube 8 X 5,5 JG PE-0806-100M-N	1350mm
23	902-013945	10mm x 8mm Reducer JG: PM061008E	1
24	902-111626	HPR Solenoid Assembly	1
25	901-013774	10mm Equal Straight Adaptor JG: PM0410E	1
26	902-013613	10mm Divider JG: RM2310E	1

Note-All hose fittings to be fastened with Jubilee Clip- See table below for detail

Hose Part No.	Jubilee Clip Size	Part No.	Quantity
604-000131	00	703-006082	2
627-000139	M00	900-005293	10

Plumbing Parts List

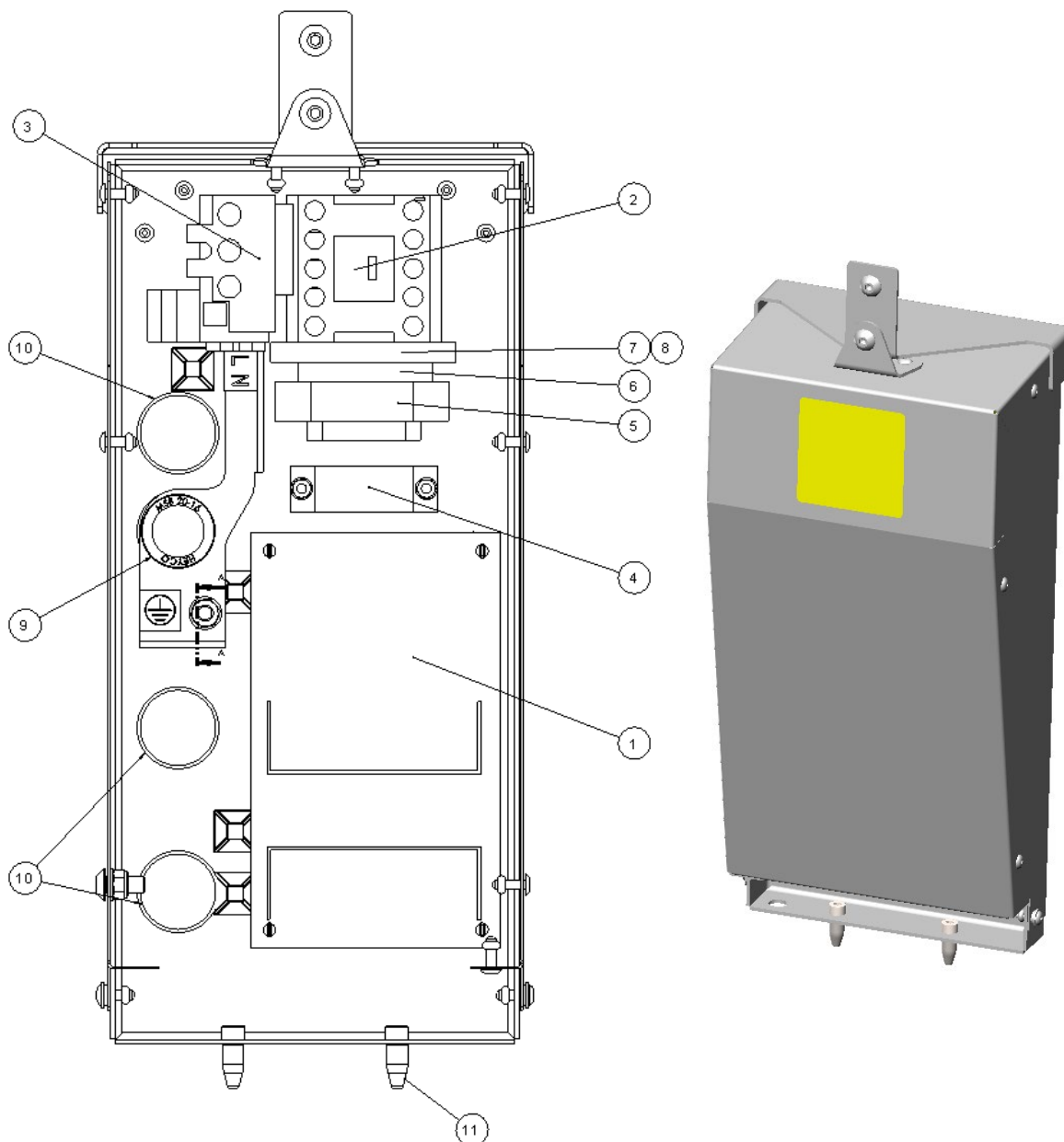

ITEM	PART No	Tag #	DESCRIPTION	1 Phase	3 Phase
1	901-111557	A6	Power Supply	1	1
2	900-030209	A4	Contactator	1	1
3	902-030154	A7	Overload Device 4.0-6.2A	1	-
	904-030154		Overload Device 1.2-1.9A	-	1
4	106-031088	A5	Relay	1	1
5	129-031012	-	End Stop	1	-
6	100-031012	-	Grey Terminal	1	1
7	125-031012	-	Fused Terminal	1	3
8	111-031099	A3	FUSE 10A HBC 20mm X 5mm Dia	1	-
	112-031099		FUSE 6.3A LBC 20mm X 5mm Dia	-	1
9	108-031131	-	Snap Bush	1	1
10	902-111517	-	Grommet	4	4
11	901-016583	-	Location Peg	2	2

Control Enclosure

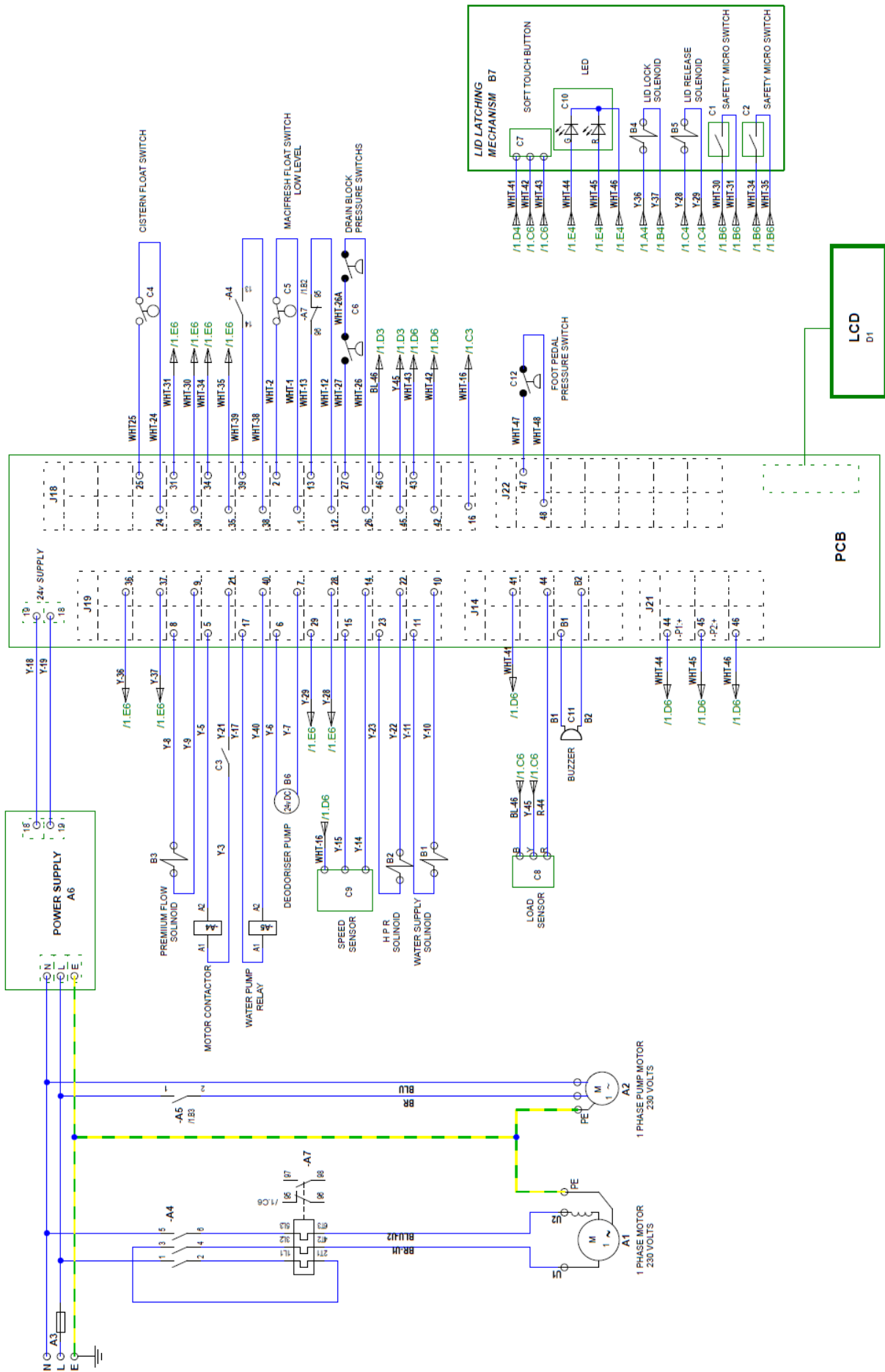

Wiring Diagram – Single Phase

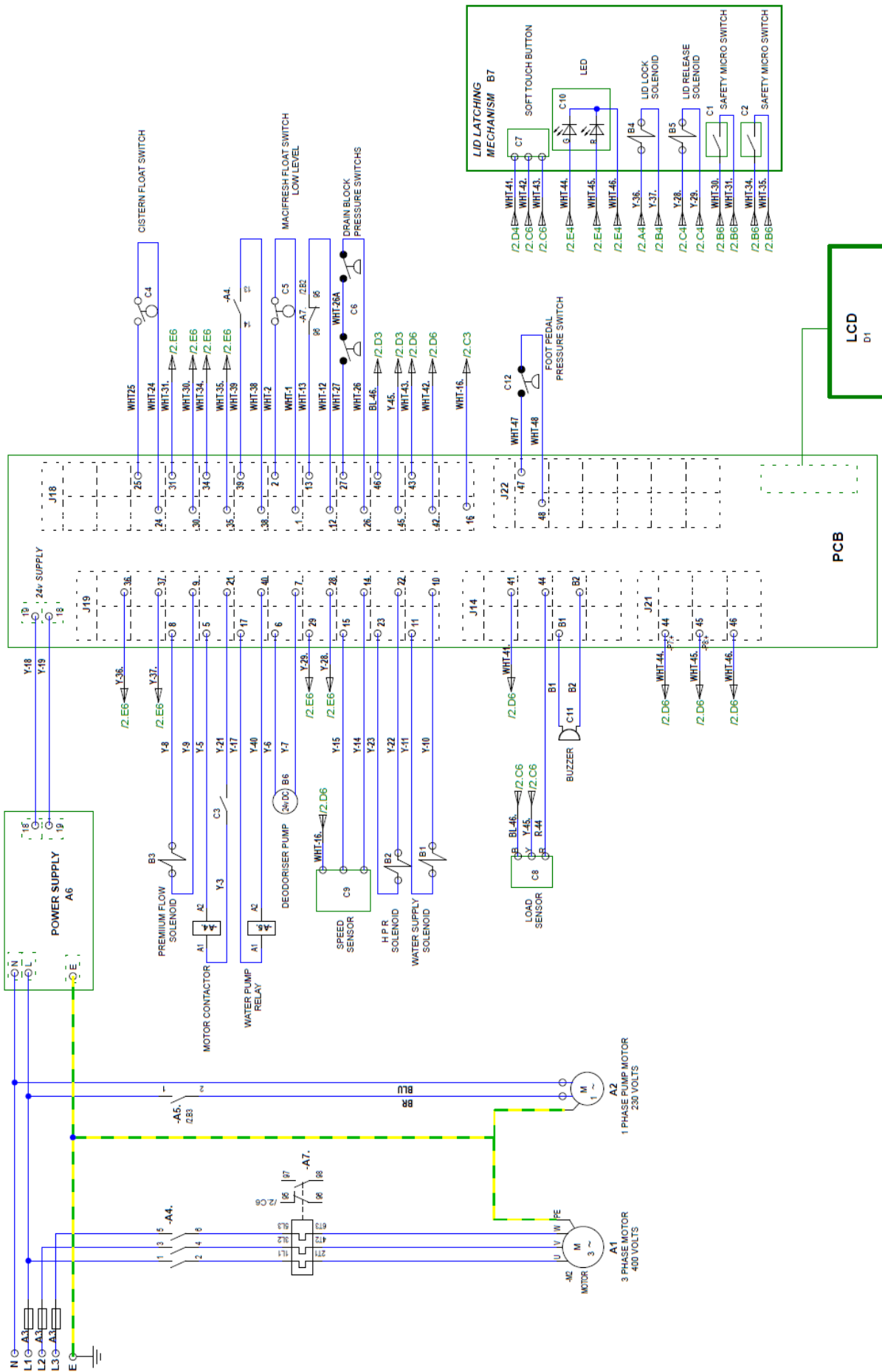

Wiring Diagram – 3 Phase

Tag	Part Number	Description	Function
A1	n/a	Motor	
A2	901-100226*	Pump*	
A3	125-031012	Mains Fuse 10A (1Φ)	
		Mains Fuse 10A (3Φ)	
A4	900-030209	Contactor	Motor control
A5	106-031088	Relay	Control water pump
A6	901-111557	Power Supply	Supply 24V DC output
A7	902-030154	Overload Device 4.0-6.2A	Motor control
	904-030154	Overload Device 1.2-1.9A	
B1	901-111630	Solenoid Valve Kit	Mains water supply
PCB	901-111516	PCB	Logic Control
B2	901-111605*	Solenoid Valve (RED Identifier)*	HPR
B3	901-103786*	Solenoid Valve (BLUE Identifier)*	Premium Flow
B4	901-030234	Solenoid (latching)	Lid Lock
B5	902-107552	Solenoid	Lid Release
B6	901-111812*	Pump*	Deodoriser
C1	900-030183	Micro-switch	Safety monitoring
C2	900-030183	Micro-switch	Safety monitoring
C3	900-003940	Positive Break switch	Break contactor coil connection
C4	902-102108*	Level switch*	Low water level indication
C5	902-102108*	Level switch*	Low deo level indication
C6	905-003571*	Pressure switch*	System pressure sensing
C7	n/a	Soft Touch Button	Signal to operate lid solenoid
C8	n/a	IR sensor	Signal to indicate load sensing
C9	901-111578	Speed sensor	Signal to indicate motor turning
C10	n/a	LED	TBA
C11	901-112530	Buzzer	Audible feedback regarding machine operation
C12	n/a	Foot Pedal Switch	Lid Opening
D1	901-111571	LCD	Visual feedback regarding machine operation

*Denotes component less fixing brackets

Control Gear

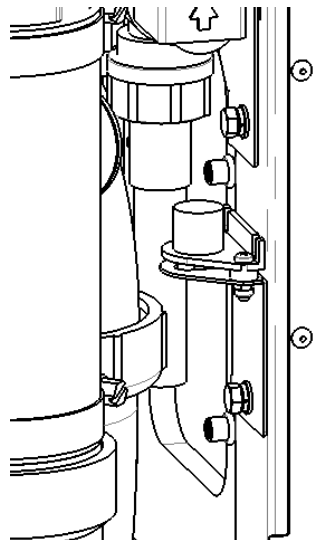
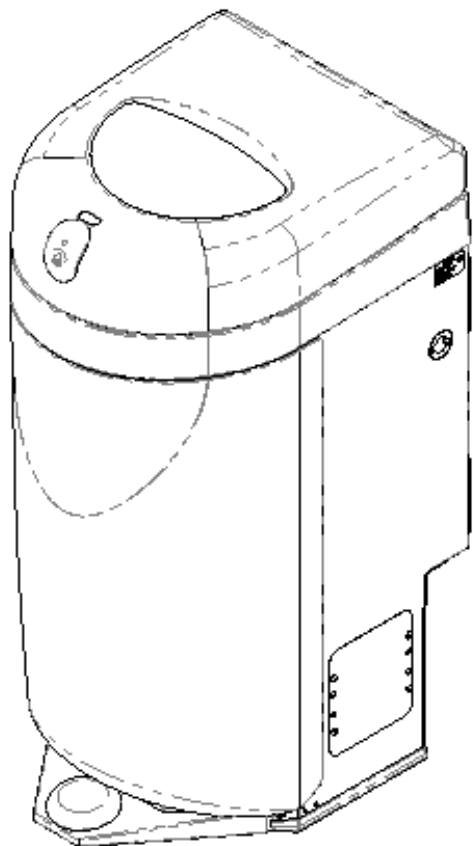

Additional Pressure Switch* Fitted in Base

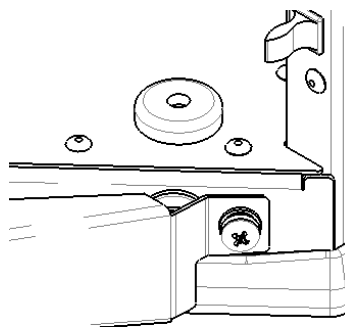

Foot Switch Fitted to Frame
(Both Sides)

Foot Pedal Hands Free Opening Kit

Part No	Description
905-112632	Foot Pedal Hands Free Opening Kit
906-112632	Foot Pedal Hands Free Opening Kit (Plinth Compatible)

* On early models the Additional Pressure Switch was fitted in Lid

6. Fault Finding & Troubleshooting

Functional Problems



Electrically isolate the machine before any maintenance







Maintenance should only be performed by qualified personnel

Always check the indicator lights on the machine before calling maintenance staff, as simple remedies may work.

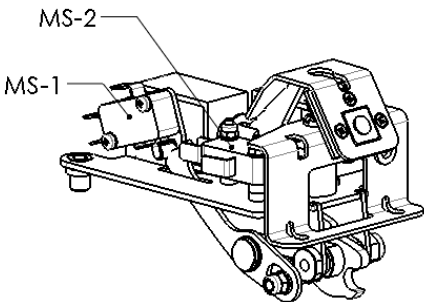
Problem	Possible Causes / Resolution
Machine is not clean internally after use	<ul style="list-style-type: none"> Lack of water or a failure to circulate within the machine. Check that the main water solenoid valve is operating. Make sure that the main isolating valve is open. Is the water isolator service valve in the 'Open' position? Check that the pump is working.
Underside of lid has a deposit after use	<ul style="list-style-type: none"> Check for foreign matter in the gap of the vent in the centre of the lid. If this is blocked, remove the vent, clean it and replace it. The jet gap must be the same around its circumference. If the problem is with the pump you will require an exchange unit for this part.
Lid seal is leaking	<ul style="list-style-type: none"> Check that the lid seal sits centrally on the lid gasket. Adjust and rectify, before making any adjustments to the latch mechanism. Remove any scum that has accumulated around the lid/hopper seal area.
Unable to open lid	<ul style="list-style-type: none"> Power failure. A solenoid on the latch mechanism locks the lid. The lid cannot be opened until: <ol style="list-style-type: none"> The power is restored. The Interlock Latch is released manually. <div style="text-align: center;"> </div> <p style="text-align: center;">Once open check the operation of the latch and replace as necessary</p>
Unable to close lid	<ul style="list-style-type: none"> Foreign object present. Investigate and remove.
Internal water leakage	<ul style="list-style-type: none"> The Pulveriser or Pump mechanical seal is leaking Fit a new mechanical seal in the main assembly, or if the pump is leaking, exchange this for a new part. The plumbing is leaking. Investigate where the leakage originates and rectify the problem. Damaged Hopper Seal. Replace the Hopper seal, ensuring that the new seal fits correctly.

Troubleshooting

Problem	Possible Causes / Resolution
	<p>Latch not engaged, display flashes</p>
F1	<p>Latch not engaged after three attempts</p> <ul style="list-style-type: none"> • Lid latch not correctly fastened. • Note - Occurs after three failed attempts to latch the lid closed. Make sure that the lid interlock is correctly adjusted, adjusted if required.
F2	<p>Safety monitor circuit malfunction</p> <p>Interlock micro switch circuit broken during machine operation.</p> <p>Remove lid cover:</p> <ul style="list-style-type: none"> • Check micro switch (MS-1 and MS-2) operation. • Check MS-1 and MS-2 circuits for continuity. <div style="text-align: center;">  </div>
F3	<p>Contactor circuit fault</p> <ul style="list-style-type: none"> • Check operation of rear positive break switch. • Main contactor fault. • Check contactor connections, replace contactor if necessary.
F4	<p>Overload trip.</p> <ul style="list-style-type: none"> • Motor has tripped out on overload, probably jammed: • Switch off at isolator and remove the obstruction from the hopper.
<p>F5</p> 	<p>Drain Block Stage 1</p> <ul style="list-style-type: none"> • Pressure in hopper has built up to trigger the pressure switch but the machine recovered and continued.

<p>F6</p> 	<p>Drain Block Stage 2</p> <ul style="list-style-type: none"> • Pressure in Hopper: • Blockage in Pulveriser exit or drain. Investigate the cause and clear the blockage. • Incorrect installation, pipe size, or position of waste pipework. 50mm minimum. • Non return/in line valves not operating correctly. Clean or replace as required. • Never use a reactive chemical drain block clearer within the machine as it will damage the seals.
<p>F7</p> 	<p>Cistern fails to replenish with water after 150 seconds.</p> <ul style="list-style-type: none"> • Lack of water in cistern: • Check that the mains inlet valve is open. • Check that there is sufficient water pressure. • Check and clean the inlet solenoid filter. • Check solenoid valve is operating. Replace if required.
<p>F8</p> 	<p>Water level fails to drop after 20 seconds</p> <ul style="list-style-type: none"> • Pump not operating or level sensor problem: • Check the pump and replace if faulty. • Check the cistern level switch and replace if faulty.
<p>F9</p>	<p>Motor Speed sensor failure</p> <ul style="list-style-type: none"> • Caution only, machine reverts to a safe state to ensure that motor has stopped before the interlock is released.
	<p>No indicators illuminated</p> <ul style="list-style-type: none"> • Power failure • No power to machine. • Check indicator membrane is connected properly. • Check fuses / electrical connections.



www.haigh.co.uk

It is the policy of our company to continually improve our products and accordingly we reserve the right to alter specifications and appearance without notice.

The Haigh Engineering Company Limited
Alton Road, Ross-on-Wye, Herefordshire HR9 5NG UK

Tel: +44 (0) 1989 763131
Fax: +44 (0) 1989 768777

info@haigh.co.uk

