

Indust FI/Waste Combo - Stainless Steel Vinyl Grate 150X100 PVC/HDPE /CU & Stainless Steel Dual Strainers

Product Code: DI4M06VX

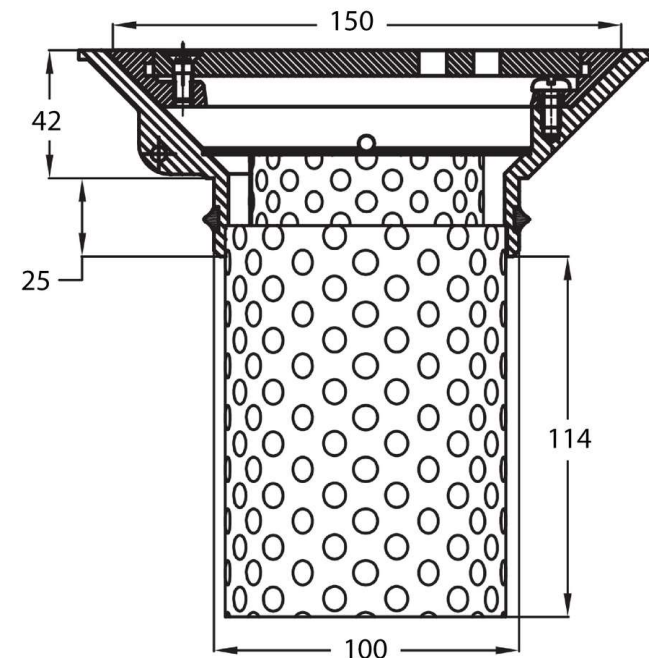

Cast stainless steel round vinyl industrial trap combination slip-in to PVC/HDPE or copper with stainless steel lock down allen key screws and removable primary stainless steel strainer and fixed secondary stainless steel strainer, load rated to Class C.

Features

- Complies with AS 3996 Class C and EN 1253 M125.
- Complies to AS/NZS 4994:1998 Discharge of commercial and industrial waste water to sewer
- Ideal for commercial kitchens, food preparation areas, shopping centres and health care facilities with vinyl flooring

Flow Rate Guide (litre/second)

Grate Size	Pressure Head mm of Water		
	20mm	30mm	40mm
150	2.1	2.8	3.5

Typical Installation

Slab On Ground

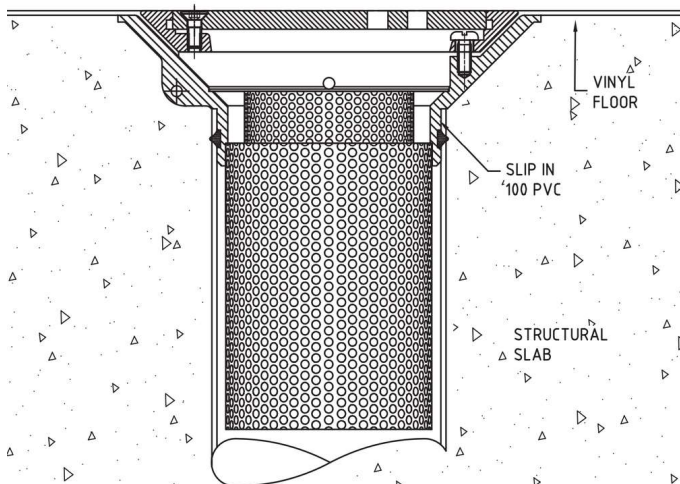



Environmental Sustainability

We are ISO 14001 certified and take sustainability seriously. Our products are environmentally responsible designed to be healthier for users, save water and/or energy, and minimise carbon footprint. Our target is to reduce our carbon footprint by 25%, and the use of non-recyclable/non-compostable materials across the company (e.g. plastics) by 50%.

Warranty

Galvin Engineering products are covered under our Manufacturer's Warranty. Galvin Engineering products must be installed in accordance with the installation instructions and in accordance with AS 3500 and NCC Volume Three, relevant Australian Standards and local authorities applicable to product being installed. Water and electrical supply conditions must also comply to the applicable national and/or state standards, failing to comply with these provisions may void the product warranty and affect performance of the product.

Please visit www.galvinengineering.com.au to view the full warranty, our Maintenance & Cleaning information and any other additional information.

While all reasonable care has been taken in compiling the information in this document, the designs, dimensions and products shown are indicative only and should not be relied upon without our prior approval. Due to our policy of continuous development, we reserve the right to alter any details of specifications or products without notice. All information, drawings, technical specifications and product designs remain the property of Galvin Engineering Pty Ltd.

Within Australia: **1300 514 074**
Outside Australia: P: +61 (0)8 9338 2344
sales@galvinengineering.com.au
www.galvinengineering.com.au



**A family
owned
Australian
business**

