

# Assembly and Installation Instructions Oil Water Separator KLsepa.compact

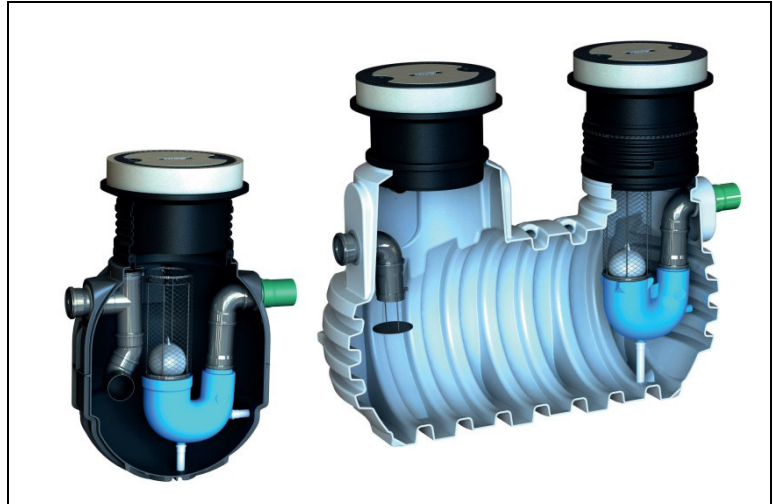
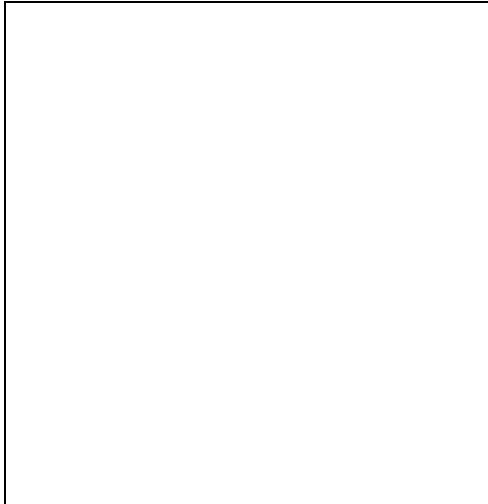

It is imperative to observe the items described in these instructions. In case of non-compliance, all warranty claims shall lapse. For all add-on items from GRAF, you shall receive separate installation instructions included with the transport packaging.

It is imperative to check the components for potential damage prior to transferring them into the building pit. The items described in these instructions apply to the separator as well as to a potential additional upstream sludge trap. For the operation and maintenance of the system, you shall receive separate instructions.

## Table of Contents

|                              |    |
|------------------------------|----|
| 1. Safety notices            | 1  |
| 2. Installation conditions   | 2  |
| 3. Assembly and Installation | 8  |
| 4. Technical data            | 16 |

# 1. Safety notices

## 1. Safety notices

The applicable accident prevention regulations in accordance with the Employers' Liability Association regulations (BGV) C22 must be observed during all work. Particularly during the walk through of the tank, a second person should be present for safety reasons.

Furthermore, all relevant regulations and standards must be observed during assembly, installation, maintenance and repair. Details hereto can be found in the respective paragraphs of these instructions.



The tank cover must remain closed at all times, except for work inside the tank, otherwise there is an increased risk of accident.



The rain protection mounted at delivery only serves as packaging for the transport and is not accessible or childproof. It must be removed immediately upon delivery and replaced by an appropriate cover (telescopic dome shaft with respective cover). Only original GRAF covers or covers approved in writing by GRAF must be used.

GRAF offers a wide range of accessory parts which are precisely coordinated and can be used to complete systems. The use of accessories that have not been approved by GRAF results in the exclusion of the warranty/guarantee.

## 2. Installation conditions

### 2. Installation conditions

#### 2.1. Installation basics

- Existing drainpipes should be checked for matching connection heights.
- The materials of the inlet and outlet pipes must be resistant to wastewater light fluids containing petroleum.
- The required pipe diameter, depending on the nominal size of the separator and the required slope of the line according to the corresponding standards (EN 752-4, EN 12056-2, EN 858-1 or equivalent AS/NZS 3500.1 and AS/NZS 3500.2), must be adhered to.
- Safety against buoyancy and flotation must be ensured.
- The installation instructions for the tank must be followed.
- A sampling option should be provided.
- Proper ventilation of the inlet and outlet pipes (according to EN 1825 or equivalent AS/NZS 3500).
- The condition of all components must be checked before installation and protected from damage or dirt.
- The covers must be comply with the latest version of AS 3996. The use of interlocking or ventilating covers is not allowed.

#### 2.2. Requirements for the installation site

- The installation site must be frost-protected.
- The installation site should be as close as possible to the wastewater accumulation location.
- The accessibility of the inlet and outlet area for cleaning vehicles and for inspection must be ensured (alignment of the shaft structures).
- The excavation base must be installed horizontally and must have sufficient base course / bearing capacity.
- The inlet and outlet lines must be installed in compliance with EN 12056 and EN 858-2 or equivalent AS/NZS 3500.1 and AS/NZS 3500.2
- Separators are to be operated without backflow by gravity. Separators with outlets below the locally specified backflow level are to be connected to the drainage system according to EN 12050 by means of sewage lifting units.
- Before filling the building pit, and possibly before connecting the inlet and outlet line, the system including shaft structure should be checked for leaks. Procedures and results of the inspection should be documented.
- Special local requirements must be taken into account (e.g. water protection area, flood prone areas etc.).

## 2. Installation conditions

### 2.2.1 Special Requirements

#### Water Corporation (WA):

A sampling point according to HX33-11-30 has to be installed after the oil water separator. Also a collection pit according to HX33-12-10 has to be installed prior the oil water separator. For technical details please refer to the typical drawings on Water Corporation website.

#### Sapphire Tank

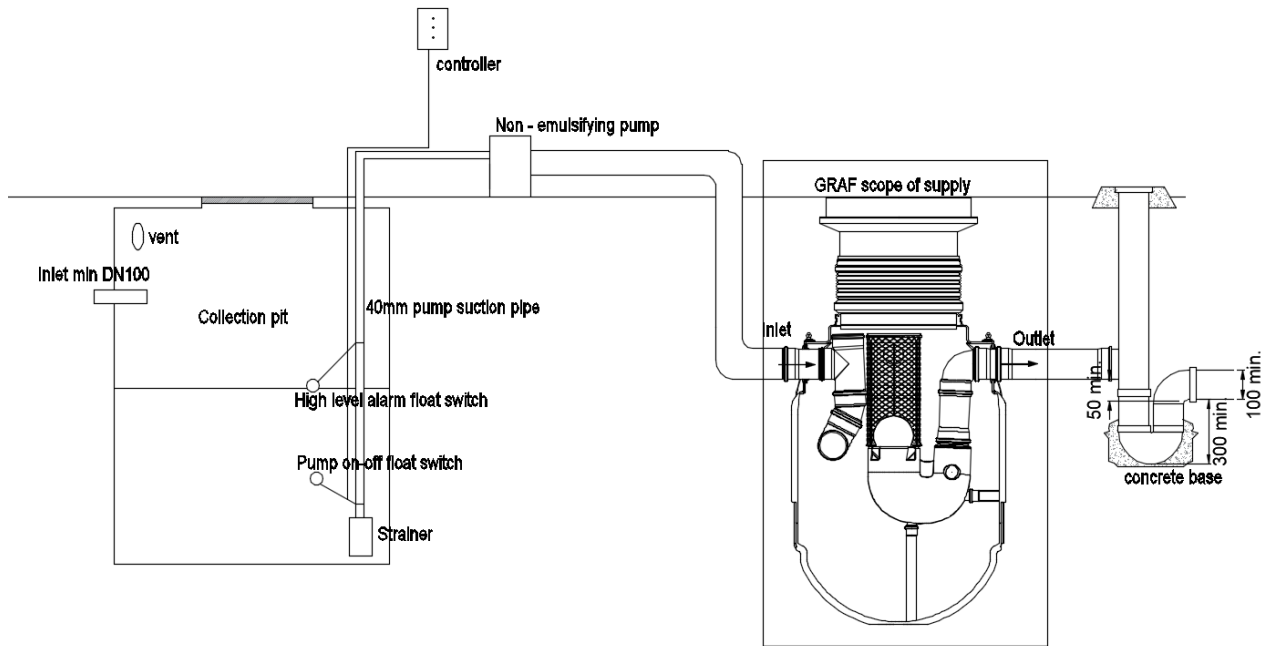

#### Diamant Tank

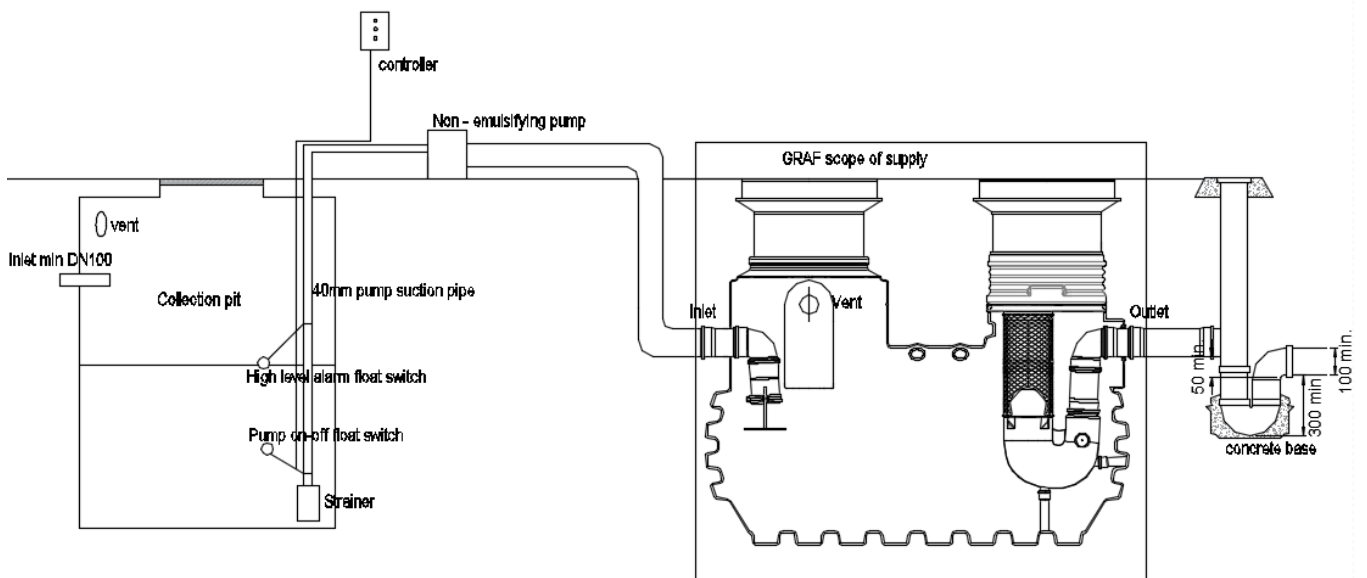

## 2. Installation conditions

### 2.3. Building site

The tank must only be installed in non-cohesive soil to slightly cohesive soil (G1 group, condition A4 and B4, degree of compaction DPR = 97 %, according to ATV-DVWK-A 127). In case of deviating installation conditions, a separate verification must be carried out.

Before installation, the following points must be clarified:

- The structural suitability of the ground.
- Maximum occurring ground water levels and infiltration capacity of the ground.

To determine the soil physical factors, a ground assessment must be carried out.

#### 2.3.1. Ground level cover

Please take note of the maximum earth covering. This should not be exceeded.

| Earth cover | Saphir  | Diamant |
|-------------|---------|---------|
| Min         | 700 mm  | 700 mm  |
| Max         | 1200 mm | 1200 mm |

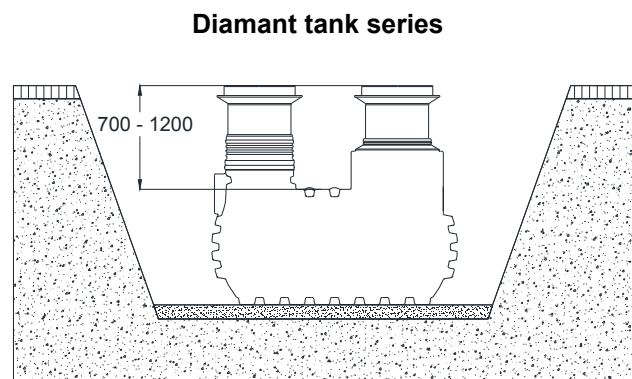
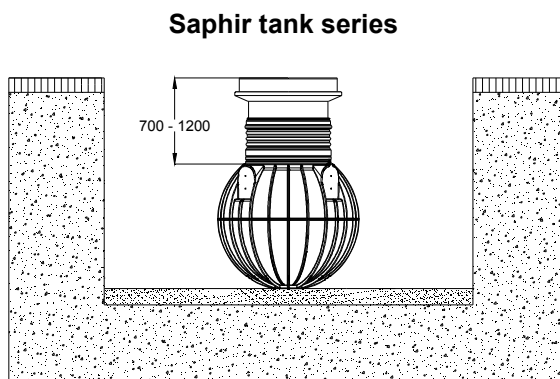

## 2. Installation conditions

### 2.3.2. Slope, embankment, etc.

During the installation of the tank in close proximity (<5 m) to a slope, mound or embankment (greater than 5°), a statically calculated retaining wall must be built to absorb the active earth pressure. The wall must exceed the tank dimensions by at least 500 mm and must have a minimum clearance of 1000 mm to the tank.

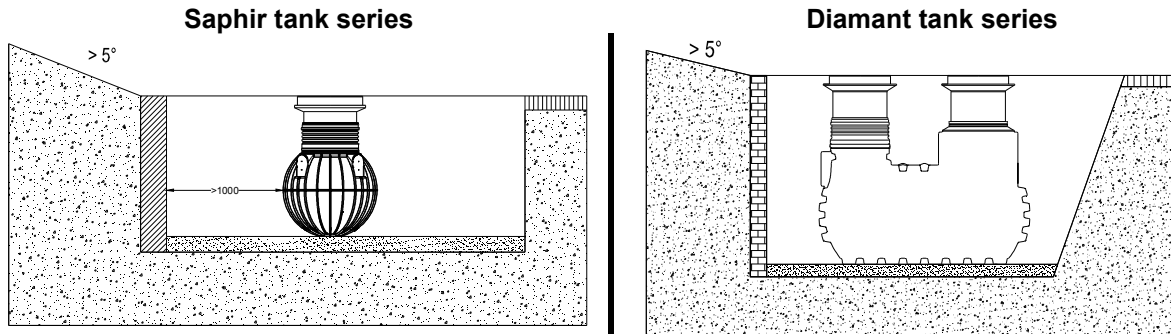

### 2.3.3. Ground water and cohesive (water-impermeable) soil (e.g. clay soil)

The tank must only be installed into groundwater/stratum water up to the levels specified in the following table. If it is to be expected that groundwater/stratum water levels - even if only occasionally - exceed these levels, it must be drained.

The drainage line may end up in a vertically installed DN 300 pipe, equipped with a submersible pressure pump that drains the excess water. The pump must be inspected in regular intervals.

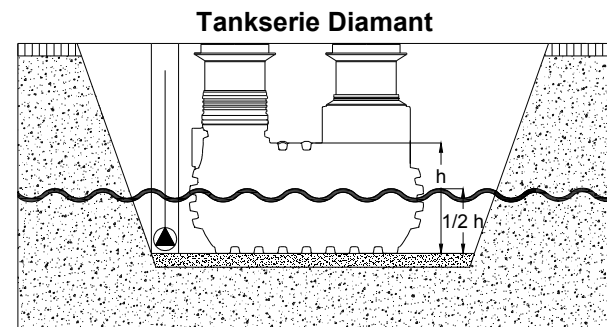
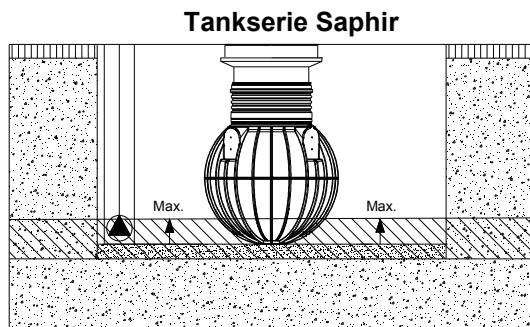

| Typ                         | max. groundwater level [mm] |
|-----------------------------|-----------------------------|
| NS3-300                     | 430                         |
| NS3-400T, NS3-600, NS6-600, | 550                         |

| Typ                    | max. groundwater level [mm] |
|------------------------|-----------------------------|
| NS 6-1300, NS 10-1300  | 575 (1/2 h)                 |
| NS 10-4000, NS 15-2000 | 700 (1/2 h)                 |

## 2. Installation conditions

### 2.3.4. Bank

The separator must be installed in a way so that the upper edge of the covers is aligned adequately high with the standard level of the area to be drained. The required banks can be taken from the table mentioned below.

| Typ                     | Bank |
|-------------------------|------|
| KLsepa.compact          | [cm] |
| NS3-300                 | 16   |
| NS3-400T,               | 19   |
| NS3-600,<br>NS6-600     | 15   |
| NS6-1300,<br>NS10-1300  | 12   |
| NS10-2000,<br>NS15-2000 | 15   |

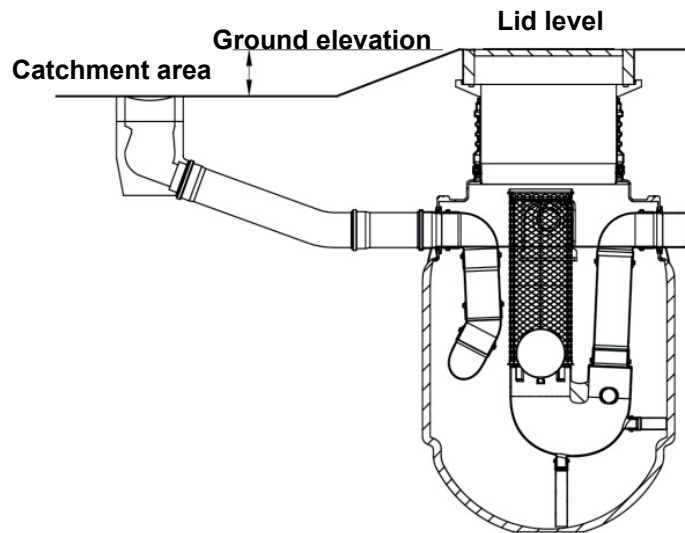

### 2.3.5. Accessible cover class A (AS 3996)

If there is no car traffic over the tank area and no load distribution plate is installed, the clearance to the passable areas must correspond with the building pit depth.

**Saphir tank series**

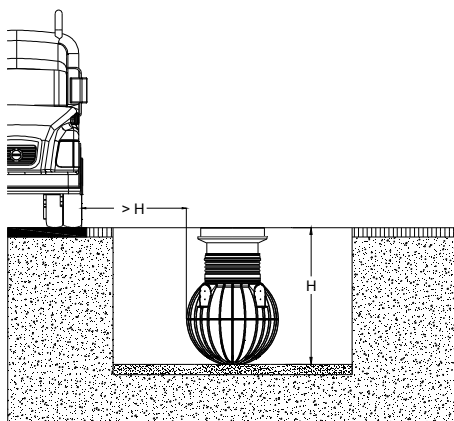

**Diamant tank series**

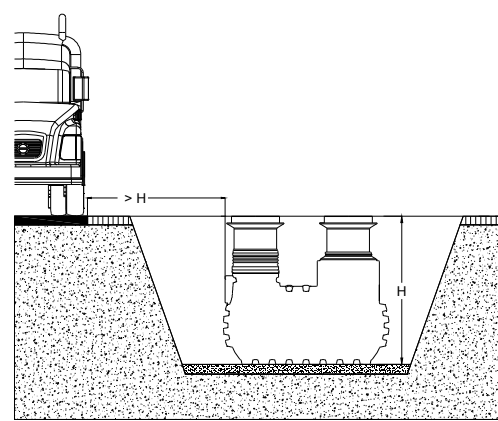

## 2. Installation conditions

### 2.3.6. Cover suitable for car traffic class B (AS 3996)

In case of car traffic, an appropriate cover according to AS3996 class B must be used. In addition, the telescopes must be equipped with a concrete collar. In reference to this, please see section 3.3.2.

**Saphir tank series**

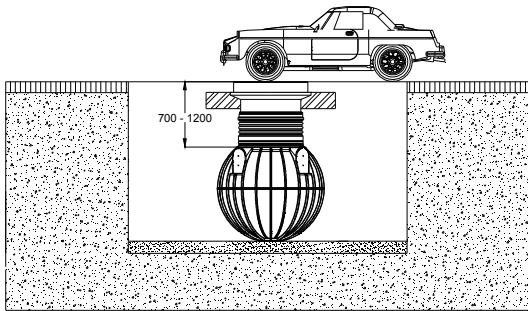

**Diamant tank series**

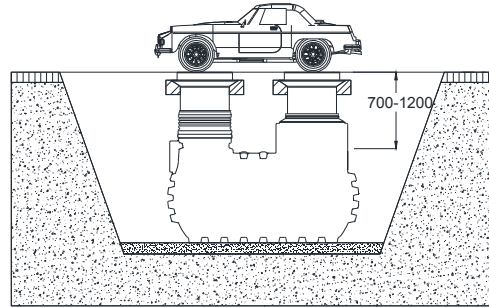

### 2.3.7. Cover suitable for truck/heavy load traffic class D (AS 3996)

In case of heavy truck traffic, an appropriate cover according to AS3996 class D must be used. In addition a load distribution plate must be provided on site (structural drawing available at GRAF GmbH).

**Saphir tank series**

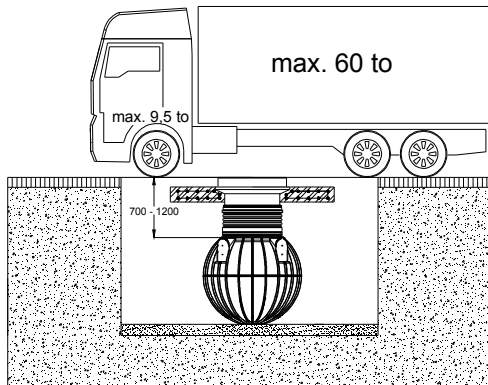

**Diamant tank series**

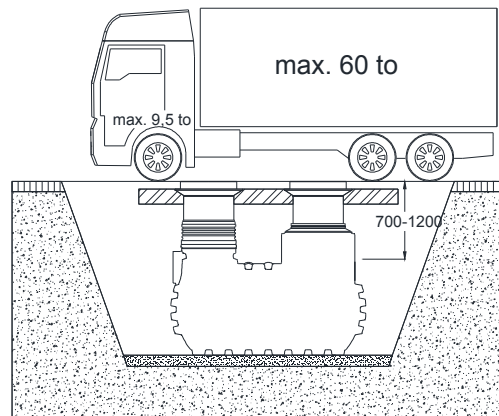



## 3. Assembly and Installation

### 3. Assembly and Installation

#### 3.1. Building pit

In order to leave adequate work space, the ground surface of the building pit must exceed the tank dimensions by > 500 mm on each side. The clearance to fixed structures must be at least 1000 mm.

A slope with the angle  $\beta$  must be applied according to the following table.

| Soil typ   | Slope angle $\beta$ in ° |
|--|--------------------------|
| Non-cohesive or soft, cohesive soil                        | $\leq 45^\circ$          |
| → Tank must be suitable for car traffic (cover B125, D400) | $\leq 50^\circ$          |
| Stiff or semi-firm, cohesive soil (tank accessible only)   | $\leq 60^\circ$          |
| Rock (tank accessible only)                                | $\leq 80^\circ$          |

Attention: In order to be suitable for car traffic, a slope angle of a maximum of  $50^\circ$  must be adhered to. The building site must be horizontal and even and must provide adequate load-bearing capacity.

The depth of the trench must be designed so the maximum earth covering from the shoulder of the tank does not exceed 1200mm.

A layer of compact grounded gravel (maximum grain size 8/16 mm, thickness at least 150 mm) must be laid down as a substructure.

## 3. Assembly and Installation

### 3.2. Final installation

#### 3.2.1. Positioning of the tank

The tank must be placed shock-proof and with adequate equipment into the prepared building pit. After placing the tank, it must be positioned in the pit in such a way that the inlet is aligned along the axis of the inlet line. The tank should be positioned vertically. After positioning the tank, fill the excavation layer by layer according to section 3.2.2.

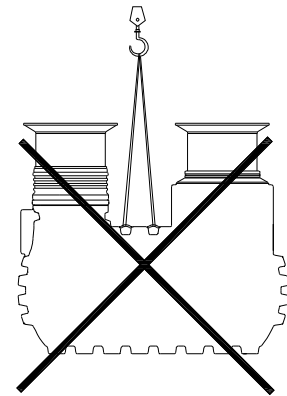

#### 3.2.2. Backfill

In order to avoid deformations of the tanks, the filling of the tank and the filling of the building pit should be carried out simultaneously. Before filling the tank, the outlet bend is filled with water (otherwise it might float and damage the assembly components!), then the tank will be filled up to 1/3; then the excavation is filled with layers of a maximum of 30 cm (grounded gravels with a maximum grain size of 8/16) up to the tank's upper edge. The individual layers must be compacted well (manual compactor). In order to prevent damage to the tank, the use of mechanical compacting equipment is not permitted at any time. The excavation must be at least 500 mm wide.

**IMPORTANT:**  
First fill up the outlet bend!

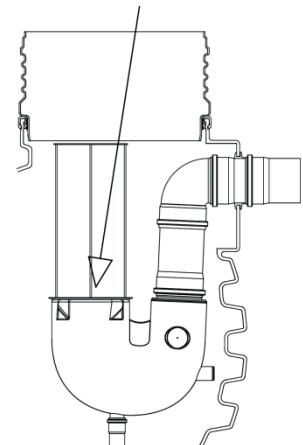

Attention: In order to be suitable for truck traffic (SLW40), a geotextile must be horizontally installed around the clearance areas!

**Saphir tank series**

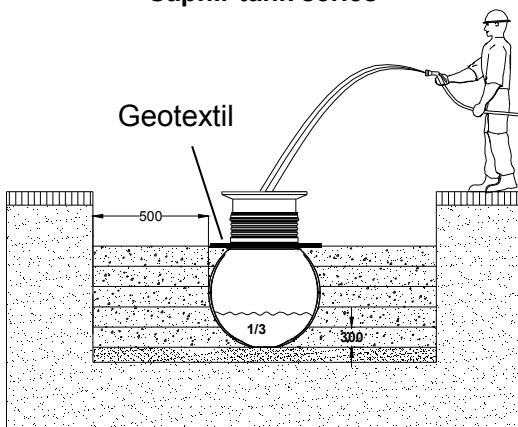

Dimensions geotextile  
1150 x 1150 mm

**Diamant tank series**

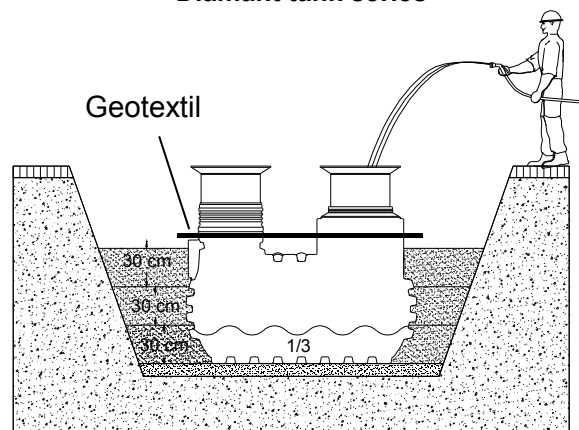

Dimensions geotextile  
NS6-1300, NS 10-1300: 1150 x 1150 mm  
NS10-4000, NS 15-4000: 1400 x 2450 mm

## 3. Assembly and Installation

### 3.2.3. Connection of inlet and outlet

When the excavation is backfilled to the lower edge of the inlet and outlet connections and compacted, the inlet and outlet lines are laid frost-protected and are connected.

After connecting the inlet and outlet lines, check whether the assembly components are in a vertical position. If they are not, position them according to the following figure.

Notes regarding the warning system:  
During the ground work, lay out the connection cables or empty pipes.

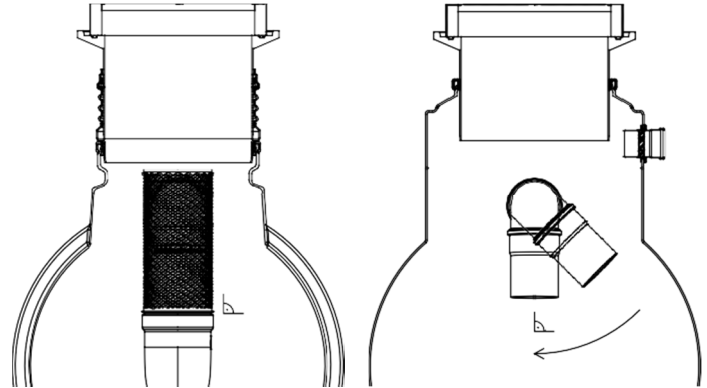

### 3.2.4. Connecting the sampling shaft

The sampling shaft must be positioned in flow direction immediately after the separator. For the installation, the installation instructions with regard to the “Sampling shaft” must be followed.

### 3.2.5. Connecting the warning system pipe

For the installation of a warning system, a borehole must be placed in the separator on the side that faces the installation site of the warning equipment. The opening should be placed as high as possible above the at-rest water level in the system.

The connecting line between the separator and the control unit must remain as short as possible. Unnecessary changes of direction, in particular such with an angle more than 45° must be avoided. The empty cable conduit must have a continuous downward slope towards the separator.

Formation of condensation inside the cable conduits can be minimised by an air-tight closure of the empty pipe on the side of the control unit. For potential subsequent wiring work, a pull wire should be added.

### 3. Assembly and Installation

#### 3.2.6. Tank installation

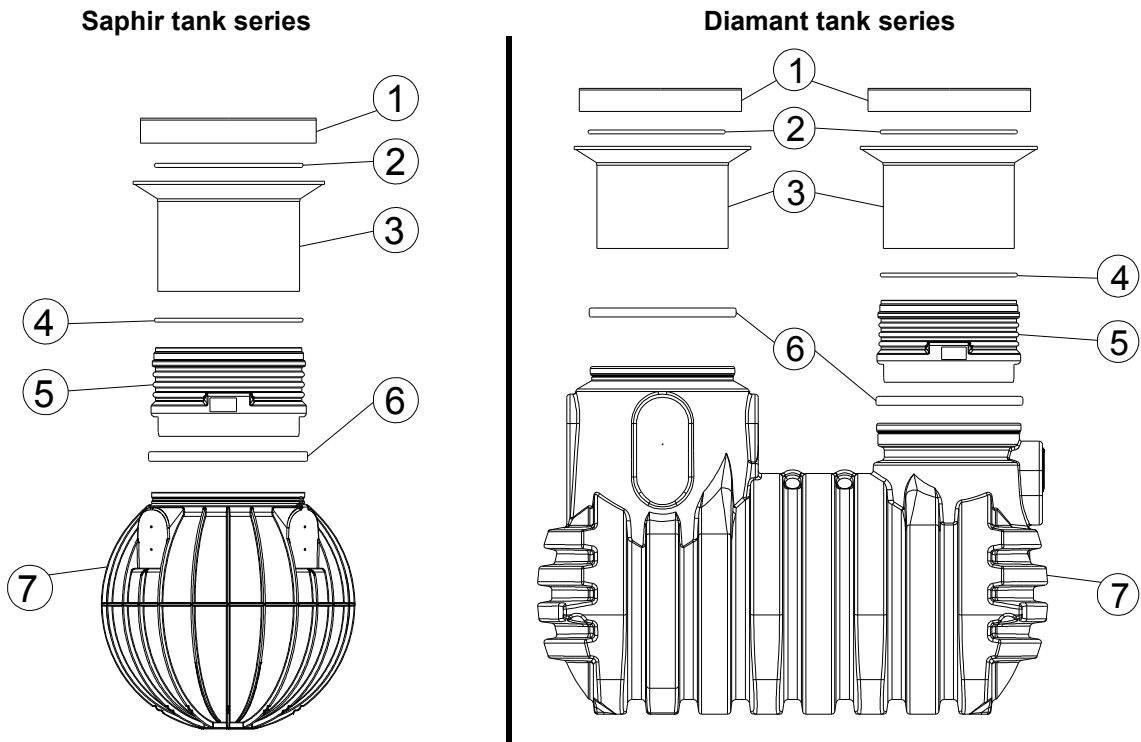

\* Up to two adaptors with respective seals can be installed.

- ① Concrete cover
- ② NBR seal
- ③ Telescope
- ④ Gasket for adaptor
- ⑤ Adaptor\*
- ⑥ Profile gasket
- ⑦ Separator tank

#### 3.2.7. Installation of adaptors and the telescopic dome shaft

The profile gasket ⑥ must be mounted onto the tank opening and the adaptor ⑤ inserted as far as the stop. Before inserting the adaptor, the seal must be lubricated with soft soap.

The seal ④ is mounted into the adaptor and the telescopic dome shaft ③ is inserted

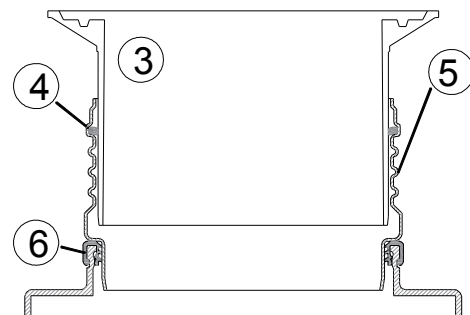

### 3. Assembly and Installation

#### 3.2.8. Installation of telescopic dome shaft directly onto the tank

In order to install the telescopic dome shaft onto the tank, the profile gasket ⑥ is mounted onto the tank opening and the telescopic dome shaft is inserted.

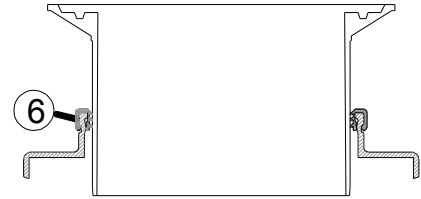

#### 3.3. Installation of the shaft structers

**Instructions regarding the covers:** The covers used for light fluid separators must meet the provisions of AS 3996. The cover(s) must not be equipped with openings to vent. It's not allowed to fastened with screws.

##### 3.3.1. Accessible

In order to prevent transferring loads onto the tank, the telescope is filled with layers of grounded gravels (maximum grain size 8/16) and compacted evenly. Subsequently an Ottocoll M500 cord is inserted into the groove of the telescopic dome shaft ③, then insert the hose seal ②. On top of the hose seal a cord of Ottocoll M500 also needs to be applied. Finally, the cover ① is placed onto the telescopic dome shaft.

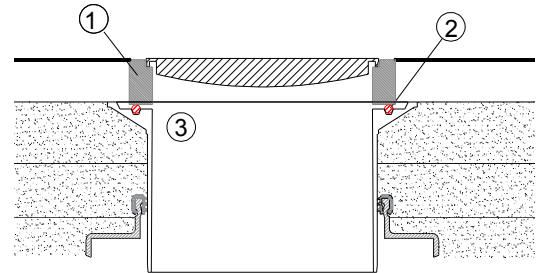

### 3. Assembly and Installation

#### 3.3.2. Suitable car traffic (class B)

If the tank is installed underneath an area with car traffic, a concrete ring (property class N25) must be placed in the collar area under the telescopic dome shaft for trucks. The circumference of the concrete layer to be filled in must be at least 300 mm wide and approx. 200 mm high. Subsequently an Ottocoll M500 cord is inserted into the groove of the telescopic dome shaft ③, then insert the hose seal ②. On top of the hose seal a cord of Ottocoll M500 also needs to be applied. At last, the cover ① is placed onto the telescopic dome shaft.

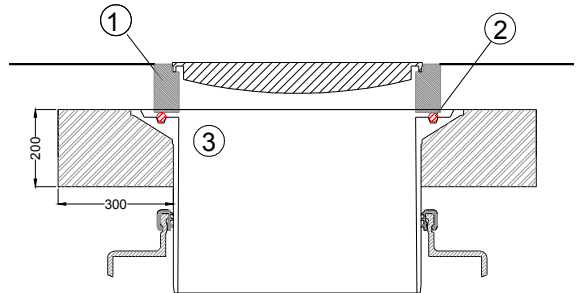

**Note!** The area is trafficable once the concrete is cured.

#### 3.3.3. Suitable for heavy load traffic (SLW40, cover D400)

A load distribution plate (property class N40) must be installed under the telescope for installations in areas with heavy load traffic. A respective formwork and reinforcement plan is available from the manufacturer. An adequately compacted, anti-capillary and draining base course must be installed underneath the load distribution plate. A geotextile must be laid horizontally at the level of the tank opening. Subsequently an Ottocoll M500 cord is inserted into the groove of the telescopic dome shaft ③, then insert the hose seal ②. On top of the hose seal a cord of Ottocoll M500 also needs to be applied. At last, the cover ① is placed onto the telescopic dome shaft.

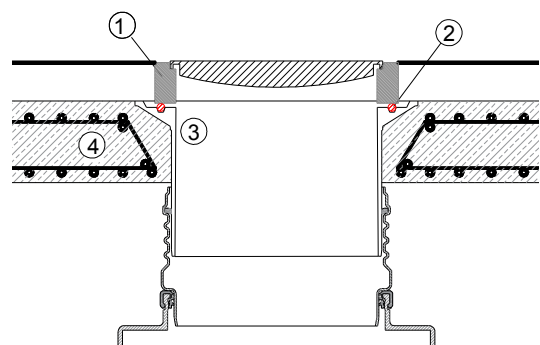

### 3. Assembly and Installation

#### 3.4. Warning system

The sensors of the warning system must - depending on the capacity of the separator - be installed on various height levels. The installation measurements are shown in the pictured table.

| Warning system type     | Oil    | High level | Sludge |
|-------------------------|--------|------------|--------|
| Clearance               | a [mm] | b [mm]     | c [mm] |
| NS3-300                 | 740    | 1200       | 460    |
| NS3-400T,               | 920    | 1550       | 560    |
| NS3-600,<br>NS6-600     | 1070   | 1500       | 730    |
| NS6-1300,<br>NS10-1300  | 870    | 1350       | 610    |
| NS10-2000,<br>NS15-2000 | 1050   | 1600       | 740    |

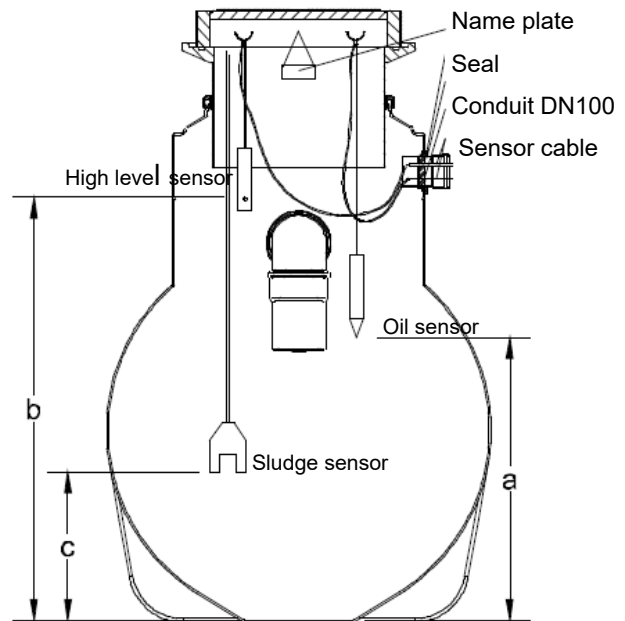

For the installation and maintenance of the warning system please refer to the attached original operating manual.

Attention: The holes for the mounting set must only be placed at the indicated positions in the concrete frame. On no account must the separator be damaged or perforated! For the process of pulling the cables through the empty pipes to the control unit the wall duct must already be tightened firmly.

## 3. Assembly and Installation

### 3.5. Commissioning

- Each oil separator is delivered with an identification plate pre-installed on the last riser closest to the finished cover level. If there isn't one in place already, please contact GRAF Australia immediately.



- To commission the separator, fill it with grease-free and oil-free water until the water begins to flow out of the discharge pipe. If a mixture of oil and water is fed into an empty tank, the separator system will not work properly and the wastewater would leave the separator system in a state that is cleaned insufficiently.
- When the separator is filled, the float must now be inserted into the guide rails of the outlet. Check, whether the float can be moved freely upward and downward. For class I separators the coalescence unit must now be inserted into the guide rails until it sits on the outlet bend.
- All relevant information, including the serial number from the identification plate must be entered into this operating manual!
- Commissioning must be documented in the commissioning report. Any claims under the warranty can only be made if the completed commissioning report is provided!



## 4. Technical data

### 4. Technical data

#### 4.1. Saphir tank series

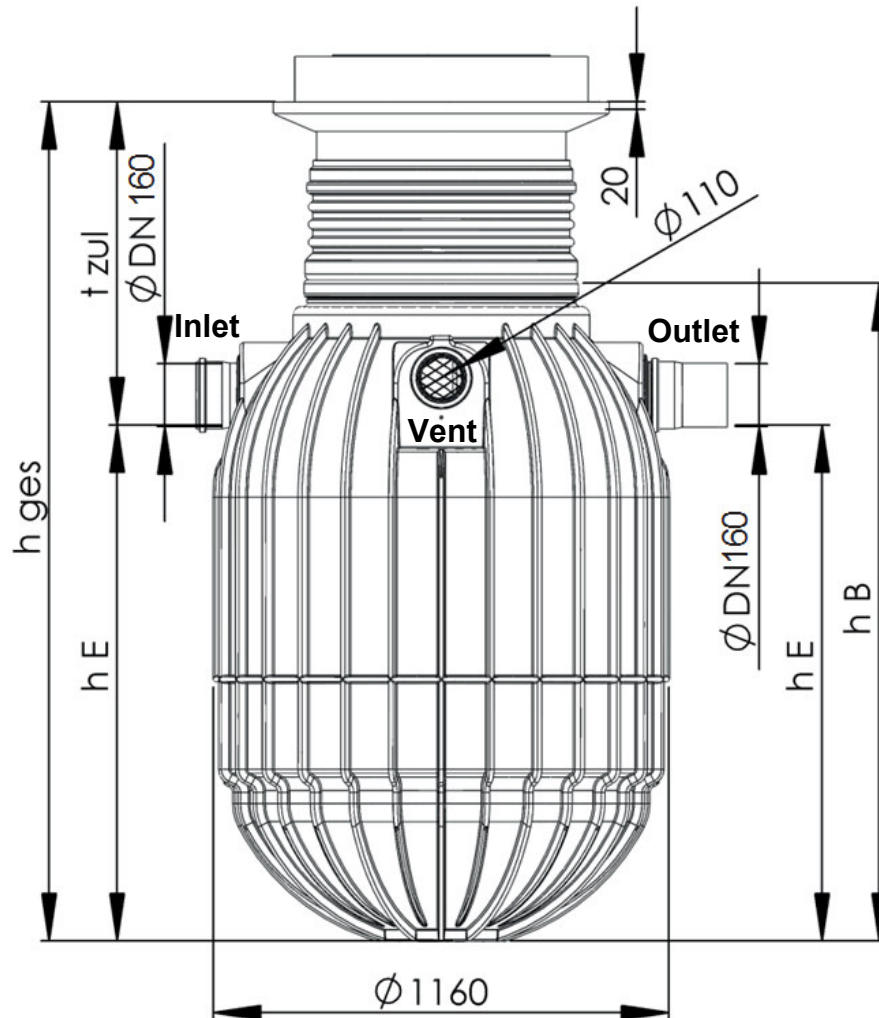

| KLsepa.compact |                       | NS 3-300    | NS 3-400-3, NS 3-600<br>NS 6-600 |
|----------------|-----------------------|-------------|----------------------------------|
| Heights        | h <sub>E</sub> [mm]   | 995         | 1320                             |
|                | t <sub>zul</sub> [mm] | 810 - 1010  | 810 - 1010                       |
|                | h <sub>ges</sub> [mm] | 1805 - 2005 | 2130 - 2330                      |
|                | h <sub>B</sub> [mm]   | 1345        | 1670                             |
| Connections    | DN                    | 160         | 160                              |
| Weight         | [kg]                  | 80          | 110                              |

## 4. Technical data

### 4.2. Diamant tank series

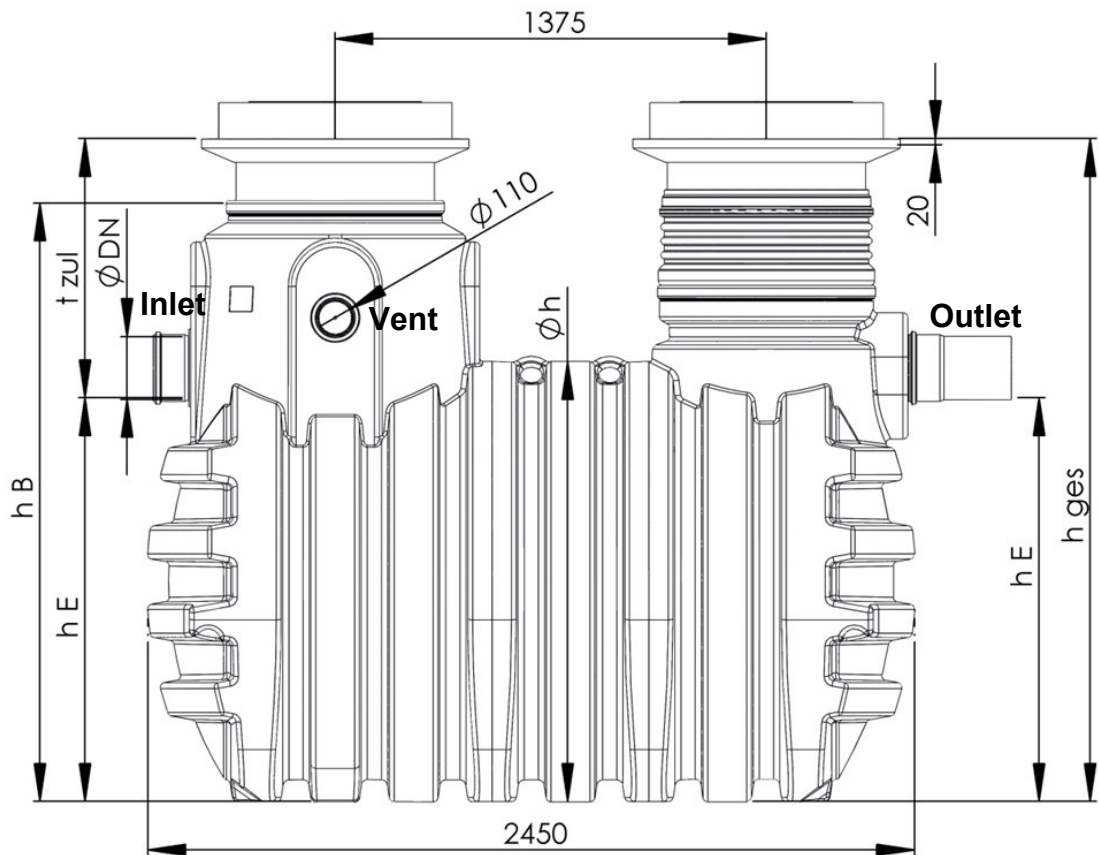

| KLsepa.compact |                | NS 6-1300<br>NS 10-1300 | NS 10-4000<br>NS 15-4000 |
|----------------|----------------|-------------------------|--------------------------|
| Heights        | $h_E$ [mm]     | 1085                    | 1280                     |
|                | $t_{zul}$ [mm] | 775 – 975               | 830 – 1030               |
|                | $h_{ges}$ [mm] | 1860 – 2060             | 2110 – 2310              |
|                | $h$ [mm]       | 1150                    | 1400                     |
|                | $h_B$ [mm]     | 1655                    | 1905                     |
| Connections    | DN             | 160                     | 200                      |
| Weight         | [kg]           | 165                     | 250                      |

## 4. Technical data

### 4.3. Sludge Traps (optional)

#### 4.3.1. Saphir tank series

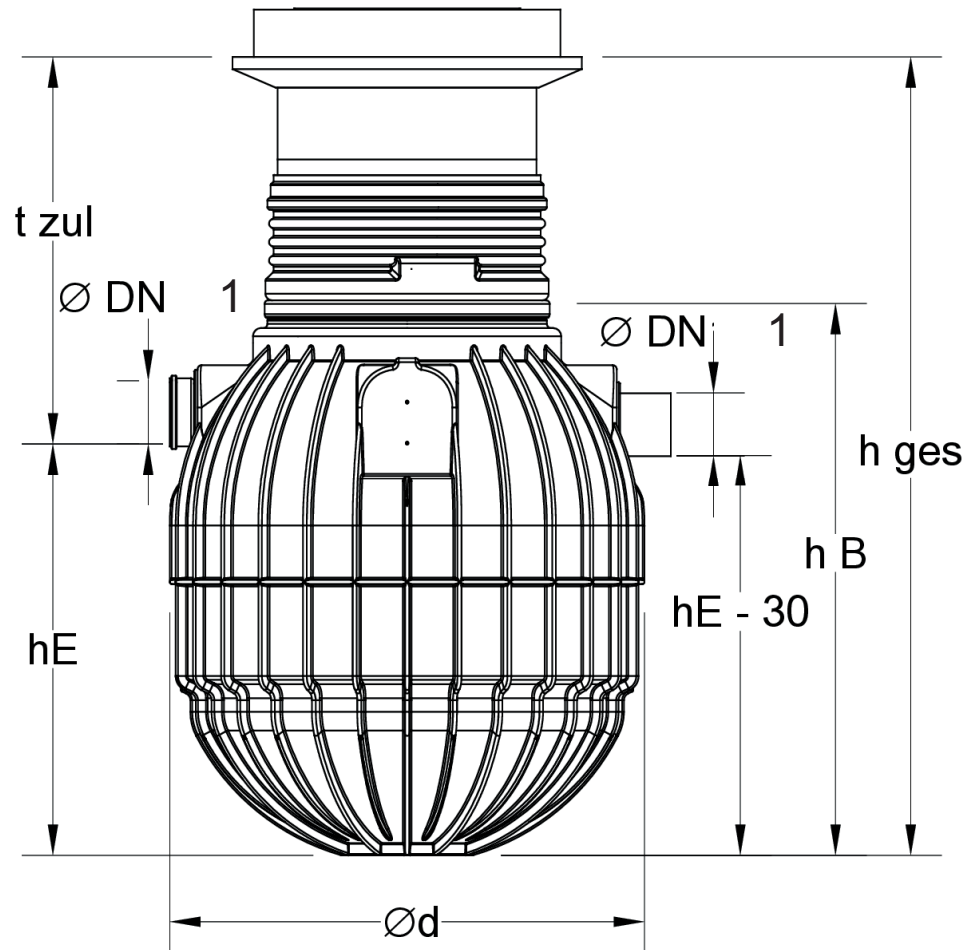

|             |                |             |
|-------------|----------------|-------------|
| Sludge trap |                | 1000 L      |
| Heights     | $h_E$ [mm]     | 1320        |
|             | $t_{zul}$ [mm] | 810 - 1010  |
|             | $h_{ges}$ [mm] | 2130 - 2330 |
|             | $h_B$ [mm]     | 1670        |
| Connections | DN             | 160         |
| Weight      | [kg]           | 95          |

## 4. Technical data

### 4.3.2. Diamant tank series

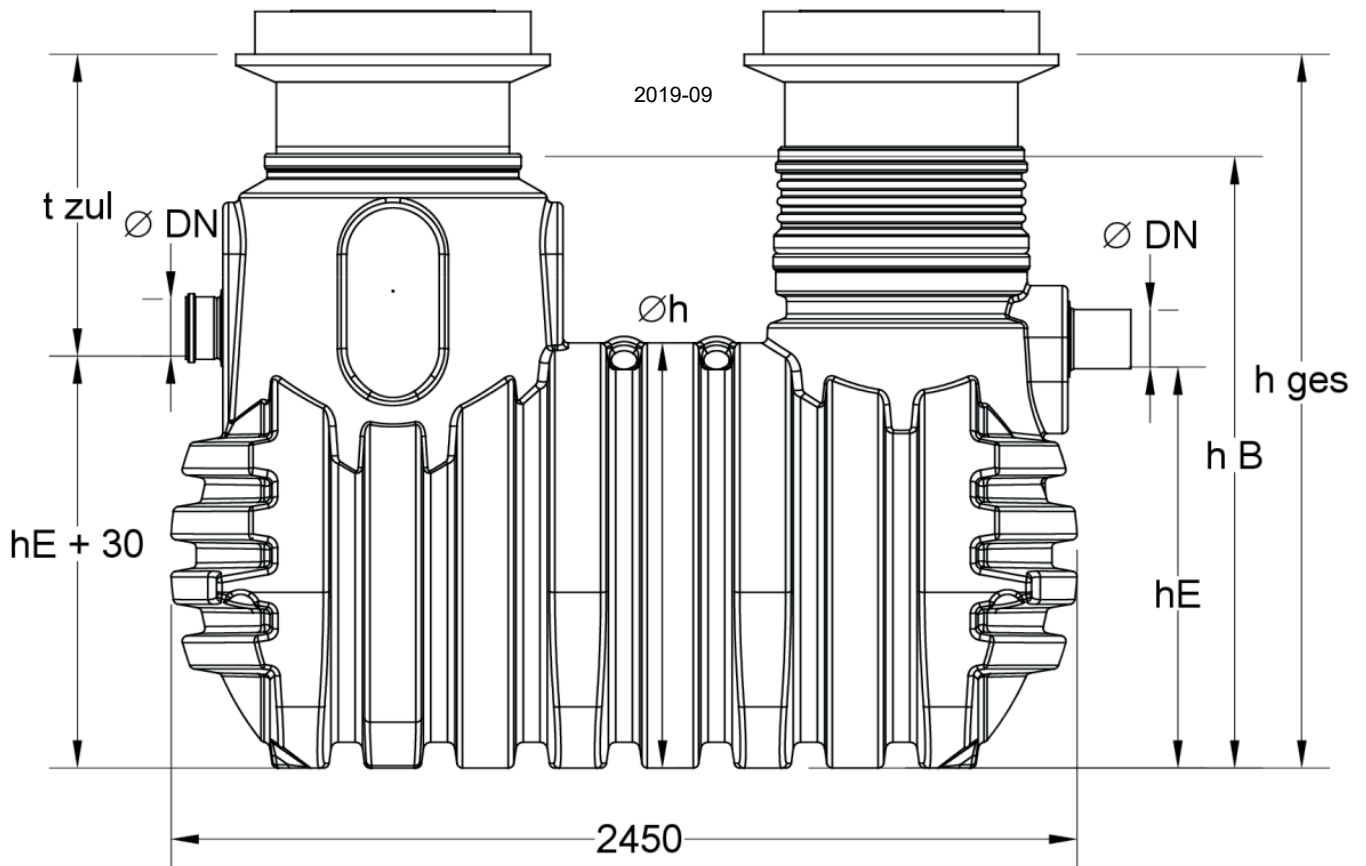

| Sludge trap |                | 2100 L      |             | 3200 L      |             | 4600 L      |             |
|-------------|----------------|-------------|-------------|-------------|-------------|-------------|-------------|
| Connections | DN             | 160         | 200         | 160         | 200         | 160         | 200         |
| Heights     | $h_E$ [mm]     | 1085        | 1060        | 1305        | 1280        |             |             |
|             | $t_{zul}$ [mm] | 745 - 945   | 770 - 970   | 775 - 975   | 800 - 1000  | 755 - 955   | 780 - 980   |
|             | $h_{ges}$ [mm] | 1860 - 2060 | 1860 - 2060 | 2110 - 2310 | 2110 - 2310 | 2410 - 2610 | 2410 - 2610 |
|             | $h$ [mm]       | 1150        | 1150        | 1400        | 1400        | 1700        | 1700        |
|             | $h_B$ [mm]     | 1655        | 1655        | 1905        | 1905        | 2200        | 2200        |
| Weight      | kg             | 155         | 155         | 240         | 240         | 250         | 250         |

## 4. Technical data

### 4.4. Sampling shaft DN600

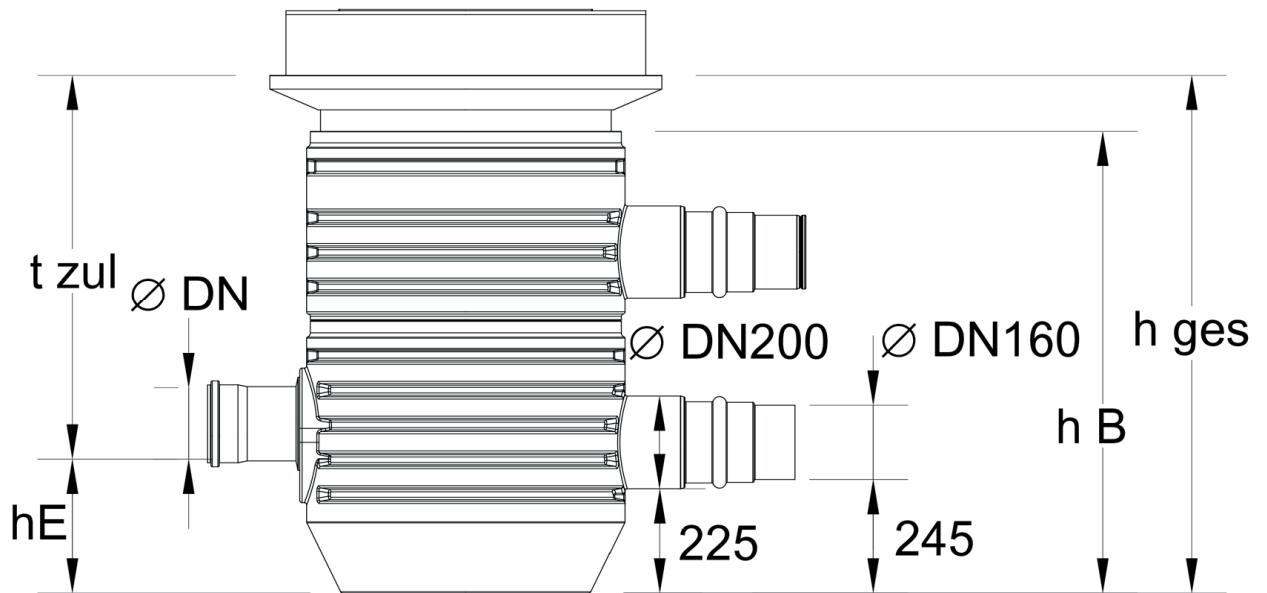

| Sampling shaft |                | DN 160      | DN 200      |
|----------------|----------------|-------------|-------------|
| Connections    | DN             | 160         | 200         |
| Heights        | $h_E$ [mm]     | 280         | 260         |
|                | $h_{zul}$ [mm] | 860 - 1060  | 880 - 1080  |
|                | $h_{ges}$ [mm] | 1140 - 1340 | 1140 - 1340 |
|                | $h_B$ [mm]     | 1000        | 1000        |
|                | Weight         | [kg]        | 19          |







