

**HAIGH**

Hygienic Solutions



**Classic<sup>+</sup>**  
Bedpan Disposal Technology



[www.haigh.co.uk](http://www.haigh.co.uk)

**WRAS**  
APPROVED  
PRODUCT



# Operating & Maintenance Manual

## Important

This technical/maintenance manual is to be regarded by the owner/operator as an integral part of the equipment, which must be available for use by the owner/service engineer as required. It must be available during the life of the equipment and passed to any subsequent owner/user if the equipment is sold or transferred elsewhere.

## Warranty

Our warranty provides a guarantee against defects in manufacture for one year from the purchase date within the UK mainland and Northern Ireland. An extended warranty or Service Contract is available by contacting our sales office.

Damage caused by misuse is chargeable and will invalidate the warranty, as will poor installation, if the machine is not installed in accordance with the installation instructions as detailed in this manual.

This warranty does not affect your statutory rights.

### Note:

In all communications relating to warranty, please quote the serial number of the machine concerned.

This can be found on a label under the handle striker once the lid is opened and another can be found on top left of the front frame when the cover has been removed.

If we can be of further assistance please do not hesitate to contact us:

## Sales

Telephone	+44 (0)1989 763131
Fax	+44 (0)1989 768777
Email	sales@haigh.co.uk

## Service

Telephone	+44 (0)1989 760230
Fax	+44 (0)1989 768777
Email	service@haigh.co.uk



## EC Declaration of Conformity

We The Haigh Engineering Company Limited

of Alton Road,  
Ross-on-Wye  
HR9 5NG  
UK

declare that the following products:

Panaway (s/n 1084G-x-xxxx)  
Classic+ (s/n 1132E-x-xxxx)  
Incomaster (s/n 1107C-x-xxxx)

in accordance with the following directives:

2006/42/EC - Machinery Safety Directive  
2004/108/EC - Electromagnetic Compatibility  
2006/95/EC - Low Voltage Directive  
2011/65/EU – Restriction of the Use of Certain Hazardous Substances in  
Electrical and Electronic Equipment Directive (RHOS)

comply with the following standards:

BS EN ISO 12100:2010 - Safety of machinery – Risk Assessment  
EN61000-6-1:2007 - EMC Immunity  
EN61000-6-3:2007 (+A1:2011) - EMC Emission  
EN60204-1:2006 (+A1:2009) - Safety of machinery - Electrical

and, by meeting all essential requirements of the directives, are marked with the CE mark.

Signed

A handwritten signature in black ink, appearing to read "Martin Price".

Name Martin Price

Position Chief Design Engineer

Date 12 March 2015



# Operating & Maintenance Manual

# Table of Contents

1. Safety Precautions & Procedures
2. Equipment Description, Process and Control
3. Installation & Commissioning
4. Maintenance & Servicing Procedures
5. Part Identification Diagrams
6. Fault Finding & Troubleshooting



# 1. Safety Precautions & Procedures

# Operating & Maintenance Manual



## Introduction

This manual provides instructions which must be followed when installing and servicing the machine.

Please note:

- The machine should only be installed by suitably qualified technicians who have read this manual.
- A copy of the manual must always be at hand where the machine or installation is being used. Relevant sections of this manual may be printed from the manual on the CD-ROM that comes with the machine.
- In addition to these general safety instructions you must observe the special safety instructions which are included in other sections of this manual.

## Safety Symbols and Instructions

### The Hazard Sign



This sign is used in the manual as a general hazard symbol to mark those safety instructions whose non-observance can result in danger to personnel or equipment

### The Warning Sign



**WARNING, RISK OF ELECTRIC SHOCK TO PERSONNEL**

This sign is used as a warning against electric voltage

- Single Phase supply - 230V
- Three Phase supply - 400V

### The Safety Sign



This sign is used to denote that appropriate Personal Protection Equipment must be worn.

## Instructions Located Directly on the Machine

**All instructions located directly on this machine must be observed and be kept completely legible at all times.**

## Electrical Safety

- Low voltage electrical equipment (less than 1000V) can cause serious or fatal injuries.
- Any person installing or maintaining this equipment should be fully competent to carry out this work.
- Such persons should be familiar with the relevant codes of practice or standards which are applicable to the country of installation.

## Preliminary Operating Advice

- This machine is designed to operate on a fully automatic cycle. During this cycle it will only stop if a fault occurs or if it is overloaded.
- If the hopper is overloaded beyond the recommended capacity the internal trip can cause the machine to stop. Continued abuse in this manner will eventually cause motor failure.
- If an emergency occurs, such as a foreign object being in the hopper, the machine should be stopped immediately by switching off the power at the isolator.

## Staff Qualifications & Training

- All staff who operate, maintain, inspect or install the machine must be suitably trained and qualified and have the necessary equipment or tools to carry out their tasks safely.
- The person who is responsible for staff supervision should define the exact areas of responsibility and scope of authority for all staff using or maintaining the machine. If a member of staff lacks the necessary knowledge, he or she must receive due training and instruction.
- Any training or instruction that may be required can be provided by the manufacturer or supplier.
- The supervisor must also make sure that the content of this manual is fully understood by the staff concerned.

## Dangers Arising from Non-Observance of Safety Instructions

- Danger to personnel and to the machine.
- Danger to the environment through leakage of hazardous substances.
- Loss of all entitlement to redress.

## Safety Conscious Working

- In addition to the safety instructions given in this manual, it is essential to follow the national accident prevention directives currently in force and any internal regulations concerning work and safety.
- Duty of care - Your personal safety, the safety of others, of the equipment and the environment is the responsibility of everyone.

## Safety Instructions for Maintenance, Inspection & Installation

- Leakages of contaminated material must be discharged in such a way that neither personnel nor the environment are placed at risk. Statutory directives must be observed.
- All possible danger from electric shock must be eliminated (for details see the regulations of the country of authority and your local power supply company).
- Observe equipment warning signs.
- The supervisor must ensure that all maintenance, inspection and installation work is carried out by authorized and qualified skilled staff, who are duly informed about the machine and/or installation after studying the manual thoroughly.
- Work on the machine must only be carried out with the machine stopped and electrical power supply turned off at the isolator switch.
- Pumps or assemblies which convey, or are in contact with, harmful media must be decontaminated.
- All safety devices (Interlocks), must be refitted and be in working order immediately after the work is carried out, and their operations checked.

## Arbitrary Modifications & Replacement of Product Parts

- Modifications or changes to the machine are only permissible after consulting with the manufacturer.
- Original spare parts and accessories authorised by the manufacturer contribute to safety.
- If unauthorised parts are used, this will exempt the manufacturer from liability for any consequences caused by the use of those unauthorised parts.

## Unacceptable Modes of Operation

- The safe operation of the machine as delivered is guaranteed only if it is used within the manufacturer's guidelines. This machine was designed on the basis of specified conditions of operation contained within the conditions of purchase of the equipment. The specifications listed in the conditions of operation are to be regarded as limit values and must not be exceeded under any circumstances.
- All users should be made aware that, if the equipment is used in a manner not specified by the manufacturer, the protection provided by the equipment may be impaired.



## **2. Equipment Description, Process and Control**



## Information about the Haigh Classic+

### About The Machine

“Haigh Classic+” consists of an electric motor which drives a pulveriser, with a separate water pump that flushes the hopper and outlet pipe-work.

Water is supplied via mains supply or a storage tank through an inlet solenoid valve. The solenoid valve is operated by the machine’s printed circuit board (P.C.B.) which receives a signal from a level switch mounted in the cistern. The water is drawn from the cistern by a separate pump and is discharged via the plumbing system into the machine. A measured quantity of deodoriser is fed into the plumbing towards the end of the cycle.

The internal surfaces of the lid and hopper are automatically washed down by the spray from a vent centrally mounted on the underside of the lid.

Switching on the wall isolator actuates the microprocessor which performs a safety monitoring assessment of the condition of the machine before the green ready to run light illuminates. The machine is now ready to start a cycle of operation.

The electrical safety system is continuously monitored by the internal microprocessor.

If a problem occurs, cycle termination devices end the cycle of operation and the respective warning or fault light will illuminate. For operation refer to the indicator panel.

This machine is a Water Regulations Advisory Scheme (WRAS), approved product with protection from contamination to the water supply provided by an ‘Air gap EN 13076, Family A, type A’.

Maceration cycle: 115 seconds.

### The Pulveriser

The pulveriser consists of an impeller rotating at high speed within a toothed cutter ring which forms the lower part of the stainless steel hopper assembly.

The impeller is fitted with two sweep blades which pulp the bedpans and urine bottles before the pulp passes on through the disposer.

- Dispose of pulp products **only** e.g. bedpans and urine bottles.
- The machine is not designed to dispose of dressings, swabs, gloves etc.
- **THESE WILL JAM THE MACHINE**

Should an unsuitable object have been inadvertently placed in the machine and the impeller become jammed, the motor overload trip will operate to stop the machine and the red fault light will illuminate.



**Always isolate the machine from mains electrical supply before servicing.**

Remove the object and ensure the impeller is free to rotate. The overload trip device within the control box will automatically reset. Close and latch the lid.

- NOTES :-  
 1. DRAIN OUTLET TERMINATES AT A FITTING SUITABLE FOR A 50mm (2") DIA PIPE STUB.  
 2. REFER TO 30255-02 FOR MACHINE HEIGHTS INCLUDING PLINTHS

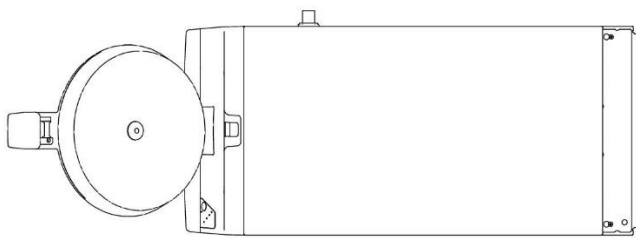
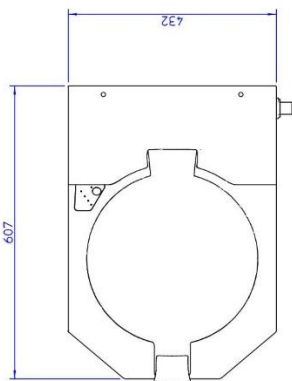

FRONT VIEW  
LID OPEN

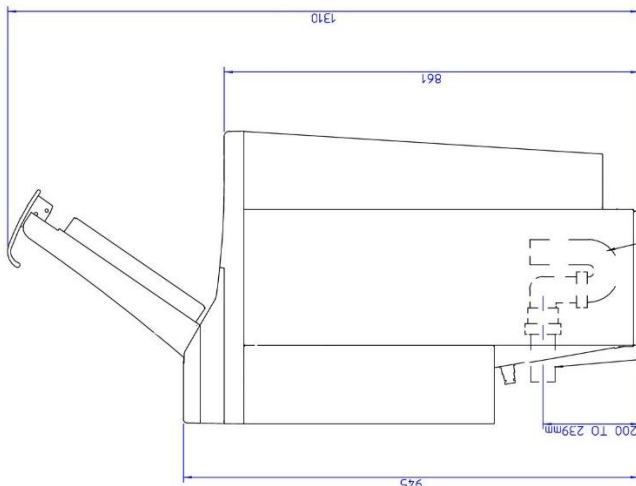

- P TRAP SUPPLIED AND FITTED INTERNALLY
- 50MM DIA DRAIN OUTLET SEE NOTE 1

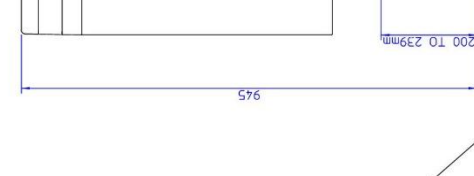

2 M LG SHEATHED ELECTRICAL SUPPLY CABLE SUPPLIED BY HAIGH

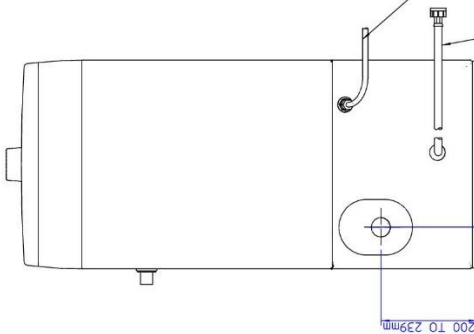

- 700mm LG 10mm BORE FLEXIBLE WATER INLET PIPE FITTED WITH 3/4" B.S.P. FEMALE CONNECTOR SUPPLIED BY HAIGH

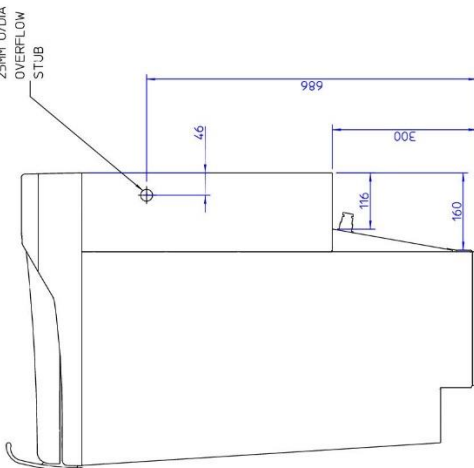

SEE SEPARATE INSTRUCTION FOR FLOOR FIXING DETAILS

## Installation Diagram



## Specification

Feature	Detail
Isolator	For single and three phase machines 20 amp Isolator to I.E.C. standards.
Water Pump	Self-primed from the cistern. Horizontally mounted only. Electric centrifugal pump.
Maximum Loading Pulp Products Only	Maximum Four. Disposable bedpan, urine bottle. Any combination of disposable bedpans or urine bottles
Pipework Connections	Mains inlet ¾" B.S.P. female connection, on hose attached to the machine. To be connected to a ¾" B.S.P. male stub and isolating valve. Rigid pipe-work only. (Supplied by customer)
	Waste Drain Outlet 50mm (2" B.S.P.) Multifit P Trap
Mains Water Inlet Flow Rate	Required flow rate. Minimum 5.5l/m Maximum: For information on flow rates above 17l/m
Cistern	16.6 Litres Capacity. Inlet protected by an 'Air gap EN 13076, Family A, type A'
Cistern Overflow Indicator	Never connect the overflow indicator stub to the drain. Ensure any discharge is Visible
Direction Of Rotation For Macerator Motor	Single phase machines are supplied with the correct rotation. Three phase machines must be checked. - Clockwise direction only when looking into the hopper. Refer to Commissioning section.
Weight Of Machine	Machine only. 83 kg. Machine on pallet. 88 kg.
Mounting	Floor 9mm base clearance holes for 8mm securing bolts





All installations must comply with statutory regulations, local water by-laws and relevant codes of practice of the country of installation. Responsibility for this must rest with the installer. The company make every effort to comply with national requirements/standards.

## Operating Your Machine

### The Indicator Panel

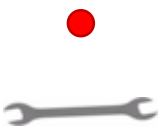

### Identification of the Symbols and Indicator Lights

	<p><b>Indicator light (Green)</b></p> <p><b>Start Button</b></p>	<p>Machine is ready to run when illuminated. Light is out while the machine is running and when a fault indicator is showing. Indicator light flashes if a problem is detected by the monitor system.</p>
	<p><b>Operation Timing Cycle Symbol</b></p>	<p>Illuminated while the machine is in normal running mode.</p>
	<p><b>Indicator light (Amber)</b></p> <p><b>Low Water Symbol</b></p>	<p>Flashes until the tank is full. Illuminated on low water condition, after 180 seconds fault light also illuminates.</p>
	<p><b>Indicator light (Red)</b></p> <p><b>Drain Block Symbol</b></p>	<p>Illuminated during a drain block cycle. On release, if water and pulp are still in the hopper covering the impeller, call the Service Engineer.</p>
	<p><b>Indicator light (Red)</b></p> <p><b>Fault Symbol</b></p>	<p>Illuminated or flashes when the machine has developed a fault. Call the Service Engineer.</p>

See Chapter 6 for troubleshooting for the above indicators

## How to Operate Your Machine

Refer to the indicator panel shown on the facing page.

With the machine plumbed in and switched on at the isolator the Start light should illuminate green.

- To open the lid manually release the lid catch to gain access to the hopper to load the machine.
- The lid is self-opening once the handle has been unlatched.
- **MAXIMUM** load for this machine:

Disposable bedpans	<b>Four</b>
Urine bottles	<b>Four</b>
Any combination of products above	<b>Four</b>

- The loading **MUST NOT BE EXCEEDED**.
- Check the indicator panel and ensure the start light is illuminated.
- The lid is pushed down to closed, clamped position. Press Start to start the machine. (Start light is out while the machine is in operation).
- The operation timing cycle indicator light will illuminate whilst the machine is in operation. The timing sequence is sufficient for the loading given above, with an automatic pause in operation cycle after maceration, for the lid latch to withdraw. For another complete cycle, load and close the lid when the ready indicator light is again illuminated.

## Operating Advice

- Operate the “Haigh Classic+ ” immediately after every loading.
- **Operator: Wash hands after every loading.**
- Never use a chemical reaction substance to clear a drain block situation in the disposer, damage to the seals will result.
- To reduce the possibility of the machine jamming, do not place the bedpans inside each other when putting them in the hopper.
- If electrical power to the machine fails during an operation cycle, the rod of the solenoid latch interlock remains engaged in the lid handle, securing the lid in locked position. The latch cannot be operated or the lid opened until power is restored to the machine.
- **DO NOT ATTEMPT TO FORCE THE LID OPEN**



### Once Daily

- Run the machine under “no load” conditions to clear any residue.

## Fault Light

- Call the service engineer if the red fault light is illuminated.
- Do not attempt any servicing yourself.



## 3. Installation & Commissioning



## Installation Instructions

Please read and familiarise yourself with the technical points contained in this section of the manual before installing this machine.

### Installation Planning

Find the best location for the machine which is as close as possible to where the dirty waste is generated. i.e. if this is on the 2nd floor then the best location for the machine is the 2nd floor.

The next consideration must be access to the main soil drain/stack for the drain connection

- Maximum run from machine waste trap to soil drain is 2 metres.
- Minimum fall of waste pipe is 1:25.
- Minimum size of waste pipe 50mm.
- Connect the machine to the drain using the minimum number of long radius/swept bends.

Having met the above points now check the availability of mains cold water and electrical supply.



**90° Bend**  
**DO NOT USE**



**Long Radius/Swept bends**  
**USE ONLY THIS TYPE**

## Unpacking the Machine

- Remove the carton and any packing materials.
- Slacken the two front panel screws, the panel will drop slightly. Pull the bottom out a little and lower it from the top brackets to access the interior.
- Slacken and remove the mounting base bolt and sleeve under the motor that secures the machine to the floor locating bracket on the pallet.
- Remove the machine from the pallet.
- Remove the bolts that secure the floor locating bracket to the pallet. The floor locating bracket will be used to fix the machine to the floor and is positioned by using the template (supplied).
- The machine is now ready for installation.

## Installation Procedure

Having established the correct position for the Machine, taking into consideration water and electrical supplies, drain, overflow indicator:

### 1. Position the template

Place the template in the desired position on the floor.

**CAUTION: Before drilling, check & position the template to ensure that the holes do not affect under floor heating or other services.**

### 2. Drill holes

Place the floor locating bracket in the position indicated on the template and drill the fixing holes. **Ensure the template is not moved while drilling.**

### 3. Remove template

Take the template away and replace the floor locating bracket.

### 4. Secure the bracket

Using the desired floor fixing fasteners (not supplied) bolt the floor locating bracket to the floor. Ensure the floor locating bracket is fitted the correct way round as indicated on the template.

### 5. Position

Lift the rear of the machine centrally over the floor locating bracket. Slide the machine forward on the runners underneath, until the floor locating bracket locates in the two guide slots in the runners.

### 6. Secure the machine and connect services

- Replace the mounting base bolt and sleeve under the motor to secure the machine in position.
- Make the waste connection from the internal 'P' trap (to mains sewage only). Ensure that connecting pipe is cut square and deburred before fitting, to prevent the waste snagging within the pipework and restricting the flow.
- The cistern overflow indicator pipe discharge should remain visible to indicate an overflow condition. If necessary a tundish plumbing device should be purchased and fitted to direct overflow water to a drain.
- Connect the mains cold water inlet supply. Open the inlet isolating valve.
- Connect the flying lead supplied ready fitted to the machine, to the installation isolator. Note advice on electrical information page.
- Turn on the electrical supply. The inlet solenoid valve opens to admit water to the cistern. Using the information in the maintenance manual will ensure the correct flow restrictor is fitted (if required) for your supply, which must be fitted immediately. The machine has a 4mm restrictor fitted as standard when leaving the factory.
- Continue with commissioning the machine. Ensure the rotational direction of the machine is correct. A direction of rotation label with cord tail is attached to the impeller in the hopper. The cord trail must indicate the trail towards the tick. This is only needed for the three phase machine.

### 7. Fit front panel

Refit the front panel. Secure with the two front panel screws.

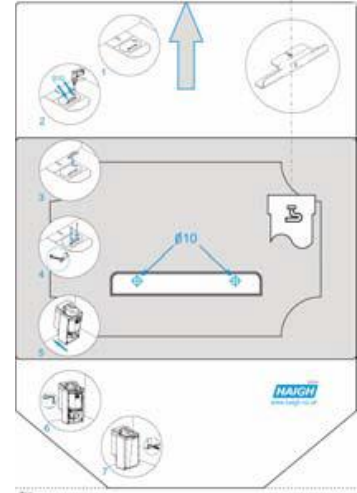



## Storage (Customer)

If the machine is not to be installed immediately, it should be stored in the carton in which it has been transported, in a clean, dry place which is free from vibration.

Undo the carton, lift the lid to periodically rotate the impeller by hand to prevent the mechanical seal seizing. Re-seal the carton after doing this.



**Industrial gloves must be worn when working on or rotating the impeller by hand.**

## Removing From Storage (Customer)

If the machine has been stored, ensure that the impeller boss is free to rotate.

The mechanical seal may have seized if it has not been revolved frequently or through water drying out.

Result: Motor will not start, or does start and damages seal faces.

To free the mechanical seal, remove the impeller and part the seal faces, lubricate with clean water only.

A new mechanical seal will be required if faces are damaged as the seal will leak.



**Industrial gloves must be worn when working on or rotating the impeller by hand.**

- Never put tools etc. on the cabinet top, these could damage the surface.
- Never allow the pump to run in a dry condition.

## Installation Information

### Builder/Installer

**Bear in mind the location and availability of power, water supply and drainage.**

- Sufficient space should be allowed for the removal of the front panel and to service the machine.
- Follow the installation instructions given within this manual.
- The machine must be level in both directions.
- Never put tools etc. on the cabinet top, these could damage the surface.
- Never allow the pump to run in a dry condition.

### Plumber

**“Haigh Classic+” needs the following installation requirements:**

- Cold water supply.
- Waste outlet connection from internal ‘P’ trap (to mains sewage only).
- Overflow indicator pipe. (Ensure discharge is visible).

## Cold Water Supply

- Ensure that the machine connection complies with statutory regulations, local water authority bylaws and relevant codes of practice.
- Ensure that the supply line to the machine is at no point less than 15mm, larger if the available head is very low.
- Ensure that the supply cannot be starved by other fittings.
- A full-way isolating valve (not supplied), must be fitted to rigid pipework only before connecting the machine to the mains or storage tank.
- The isolating valve should be placed close to the machine so that it is readily accessible during maintenance or servicing. Service connections are shown on installation sheet, with a suitable inlet hose and fittings provided for customer's water inlet supply and cistern overflow. The inlet pipe is to be connected to the hose provided which is already connected to the inlet solenoid valve that feeds the internal cistern.
- Preferred connection -- Mains supply, though connection via a break tank is permissible, providing sufficient head and pipe size is used to meet the **minimum** flow rate requirement of **5.5** l.p.m. at connection. Check the information overleaf for the flow rate restrictor requirements applicable to your machine.
- The cistern is fitted to this machine and provided with an 'Air gap EN 13076, Family A, type A' to prevent the back syphonage of contaminated water.



- **UNDER NO CIRCUMSTANCES MAY THE CISTERN BE BYPASSED.**

## Water Inlet Flow Restrictors

- Fit the correct supplied restrictor as required (see below) into the outlet of the solenoid valve.

### Important

- To optimise the water supply to your Haigh Classic+ during operation, your machine is fitted with a flow restrictor in the outlet pipe connection of the solenoid valve. This restrictor balances the water requirements of the machine to your water supply pressure. If your water supply pressure is high then you will hear the water "hiss" as it flows into the machine, and/or the solenoid will operate more than twice in a cycle (you will be able to hear the water supply come on and off to indicate that the solenoid has operated). If your water pressure is low, then the orange low water light will come on at the end of the cycle for an unacceptably long time.
- Your machine is supplied with a set of three restrictors, with the 4mm restrictor already fitted. If the orange low water light is on for more than 5 seconds at the end of the cycle, then you should fit a larger restrictor or remove the restrictor completely.
- If the solenoid is operating more than twice in any cycle (ideally the solenoid will operate once, but twice is acceptable), or if you are experiencing a lot of water "hiss" then fit a smaller restrictor.
- Keep the unused restrictors in the machine cabinet, in case you may decide to alter this setting, or move the machine to a different location which may have different water pressure, at a later date.

## Overflow

The overflow indicator pipe from the integral cistern needs to be run to a suitable position. A 1" nominal push in socket is fitted to the cistern for customer connection.



- Ensure that discharge from the overflow is visible.
- **Do not connect the overflow back into the soil drain.**

## Waste Outlet Connection



- The machine is fitted with a 50mm 'P' trap inside the cabinet terminating in a compression fitting suitable for a 50mm pipe stub. The outlet is for rear connection. Fitting a slow bend will allow for alternative connections through the floor / to the right / and to the left.
- **Never connect waste outlet to a septic tank.**
- Ideally machine to be positioned adjacent and waste must be run separately, to a 100mm vertical soil stack.
- Ensure that route taken to the soil stack is shortest, with minimum number of bends. Use long radius or 'swept' bends - never short bends or 90° elbows.
- Minimum recommended waste pipe size 50mm.
- Ensure that there is a continuous fall of 1:25 or sufficient to maintain a self-cleansing velocity and provide easy access for rodding.
- Ensure a clean run inside pipework - no burrs or reducing shoulders.
- Support plastic pipework adequately on runs to prevent sagging. Remember ceiling voids can get very warm.
- Avoid running the drain line near or across hot water pipes.
- A straight pipe run is preferable but if necessary any change of direction must be kept to a minimum, with an overall length run of two metres. However, if you need to exceed this length please contact Haigh Engineering for further assistance.

## Electrical Information

"Haigh Classic+" is supplied for use on either single phase or three phase power supplies.

Refer to the rating label details on the top of the electrical connection cover of the machine.

- Appropriate I.E.C. approved cables have been used.
- All electrical installations comply with current I.E.E. regulations.
- The appliance is connected to a protective earth connection via the earth terminal and identified by the earthing label.
- Isolator (customer supply) to be mounted adjacent to appliance.
- A 2 metre cable flying lead is supplied ready fitted to the machine for connection to the customer's isolator.
- Mains supplies always to be protected by I.E.C. approved circuit breakers or fuses.
- The thermal relay overload device should always be set for a value corresponding to the rated current of the motor. The overload is preset before leaving the factory in the automatic reset mode.

## Existing Installation

Where an isolator and a lead is already present from a previous installation, fit a junction box (not supplied) to the wall and connect the lead and the 2 metre flying lead of the machine into the junction box.

The following recommendations can be used as a guide:

	Single Phase	Three Phase
Rating	Refer to Rating Label	
MCB to ESEN 60898 Type D	6 Amp	4 Amp
Fuse to BS 88 HRC	13 Amp	6 Amp
Connection Cable	1.5mm <sup>2</sup>	

## Commissioning

Commissioning must be carried out by person(s) suitably qualified and authorised to carry out mechanical and electrical maintenance.



**Check that the machine is isolated from the electrical power supply. If not, isolate.**

### Mechanical checks

- Ensure the machine has been securely bolted down.
- Clean off any accumulated surface dust and dirt.
- Check inside the machine & surrounding area for tools, fasteners, rubbish or other foreign objects and remove them accordingly. Most problems which arise during the first hours of operation are caused by such matter.
- Check that the water is connected & turned on.
- Check that the drain is connected.

### Electrical checks

- Check that the electrical connection is made in accordance with the previous section.

### Impeller direction of rotation - three phase machines only

The rotational direction of a single phase machine is correct when dispatched, but a three phase motor can be wired correctly when testing at the factory but incorrectly when the machine is installed. Pulp products remaining in the hopper is the result of incorrect rotation.

- Open the lid & look into the hopper to see the rotation indicator label and cord that is affixed to the impeller.
- Close the lid & start the machine.
- Open the lid after the cycle is completed and observe the direction of the resulting cord trail.
- If the direction is towards the 'X' the motor is revolving in the wrong direction. **If so reverse the phases at the connection to the isolator**

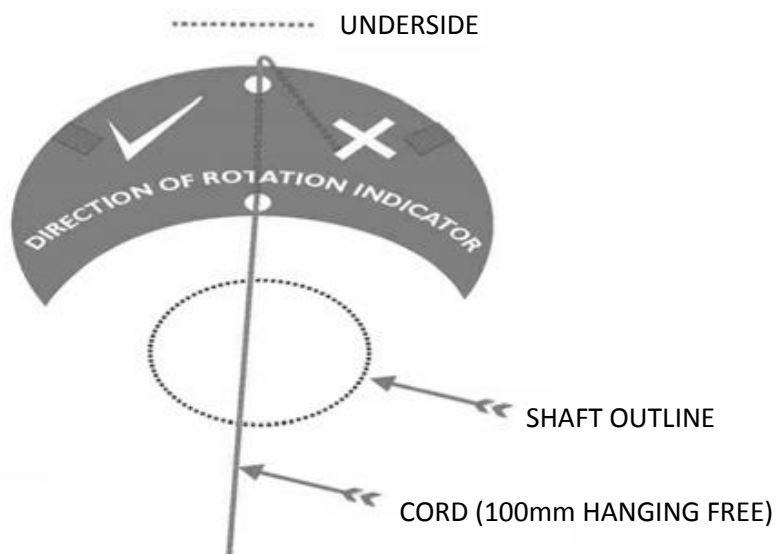



## **4. Maintenance & Servicing Procedures**





## Routine Maintenance



**Electrically isolate the machine before undertaking any routine maintenance.**

### Daily

- Run the machine under “no load” conditions to clear any residue.

### Monthly

- Lid spray- remove any scale and replace.
- Check that the lid micro-switch and solenoid latch operate.
- Check for leakage from the pulveriser and water pump seals.

### Quarterly

#### Water Supply and Drainage

- Check for leakage from the pulveriser or water pump seals.
- Check for leaks cold water supply pipe-work.
- Check that the machine is draining correctly.
- Check that the drain block pressure switch tube is clear of water.
- Check and clean solenoid filter or replace.

#### Mechanical

- Check wear on the hopper cutter ring/impeller.
- Check that the impeller is rotating freely and for absence of vibration.
- Inspect and tighten nuts and bolts as necessary.
- Check the condition of the lid/hopper seal, and that the lid opening gas spring operates correctly.
- Check the lid latch arrangement. Turn isolator off during an empty cycle to simulate a power loss and ensure that the solenoid has secured the latch in the locked position.

#### Electrical

- Check contactor is operating correctly in control gear.
- Check overload units operating and set correctly.
- Check lid positive break interlock switch operates correctly.
- Check electrical connections in control gear and motor terminal box are secure.
- Low water sensor and drain/hopper block pressure switch operate.

Functionally test the machine.

## Cleaning Recommendations



**Electrically isolate the machine before cleaning.**



**Never use a wet solution to clean the indicator panel.**

### Daily

- All exterior panels to be wiped over with normal cleaning solution for worktops etc. (soapy water) and then dried.
- The best results are obtained by opening the lid which allows full access to the seating and the lid seal.
- All internal surfaces are automatically cleaned by the machine. **Failure to do so must be investigated.**

### Weekly (As Required)

- The lid seating area should be scrubbed with a brush, wiped and the neoprene seal washed with the same cleaning solution.

## Lubrication

The machine is designed for minimum maintenance.

- The clip bushes used in this machine must **not** be lubricated.
- Apply anti-seize compound if indicated.
- The motor is fitted with sealed for life bearings.
- The mechanical seal face must be perfectly clean.
- Use only clean water to lubricate the seal face.

## Ordering Spares

Spares are identified in Chapter 6 of this manual and can be ordered from Haigh Engineering.

Telephone      +44 (0)1989 760230  
Fax                +44 (0)1989 768777  
Email             service@haigh.co.uk

Please quote the following information

- Your contact details
- The machine serial number
- The part number required
- The full part description
- The quantity of each part required
- The invoice address
- The delivery address

Failure to state the above details may cause delay in the delivery and accuracy of the parts required.

If required a kit containing recommended spare parts for this machine is available from the contact details above.

## 5. Part Identification Diagrams



## Servicing the Haigh Classic+



Ensure appropriate protective equipment is worn



**ALWAYS** isolate the machine from mains electrical supply before servicing

Isolate the water inlet to the pump at the service valve by turning the isolation screw 90°.

Reverse to vertical on completion.



Denotes assembly step

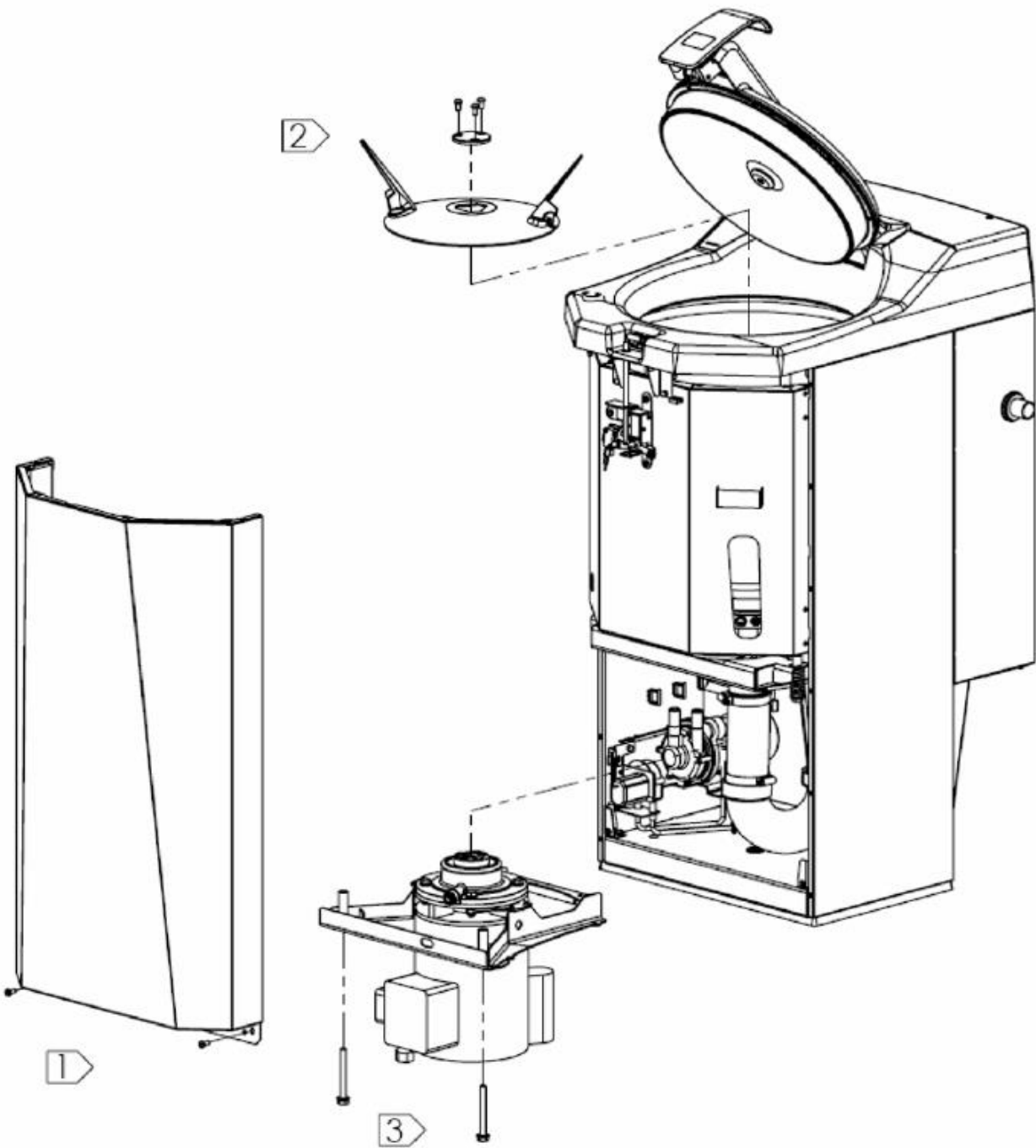

Mechanical Assembly Removal Diagram

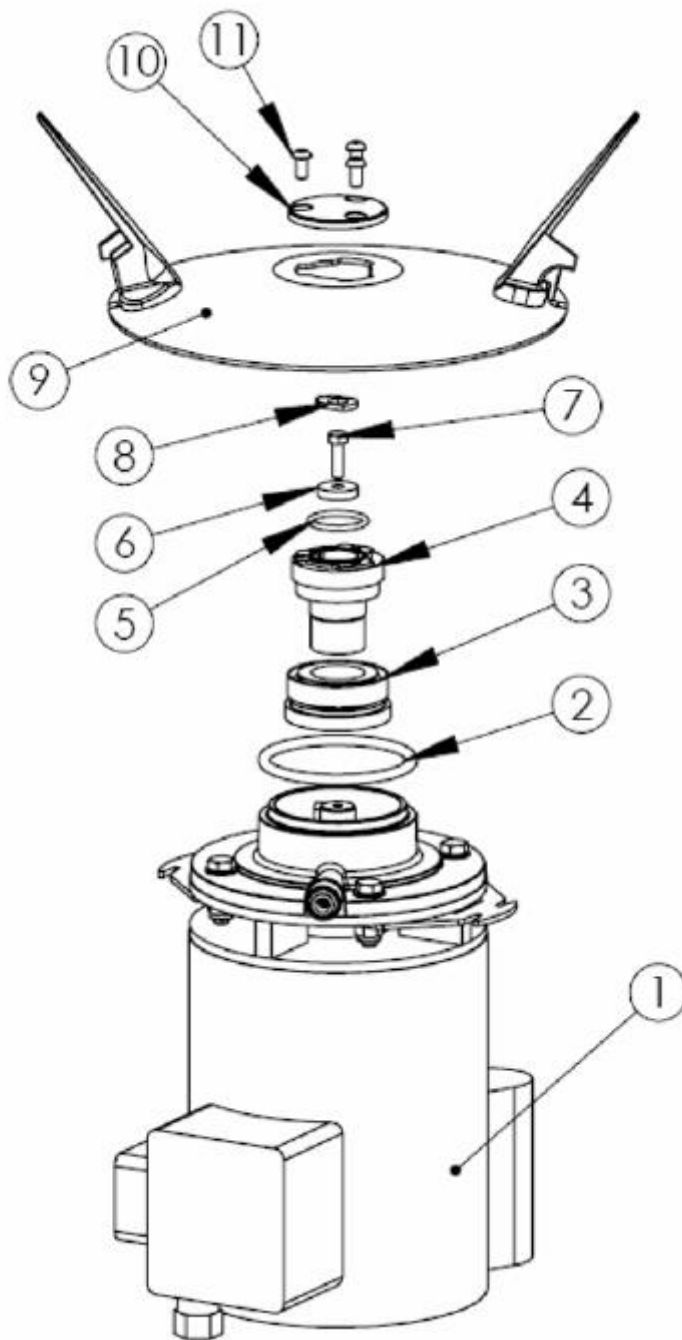

Item	Part No	Description	Qty
1	901--102101	Motor Assembly Single Phase 230V	1
	902--102101	Motor Assembly 3 Phase 400V	
2	955-051206	"O" Ring BS 0743-57	1
3	901-013926	Pacseal 118 x 30mm Shaft	1
4	901-013921	Impeller Hub D80	1
5	961-051206	"O" Ring Ref 0265-30	1
6	901-013922	Hub Washer	1
7	761-006110	Screw M6 x 20mm Hex Head Set Tufflok	1
8	901-103841	Lock Washer	1
9	901-101176	Impeller Sub-assembly	1
10	901-013923	Hub / Impeller Cap	1
11	766-006110	Screw M6 x 12mm Button Head Tufflok	3

**Mechanical Assembly Servicing Diagram**

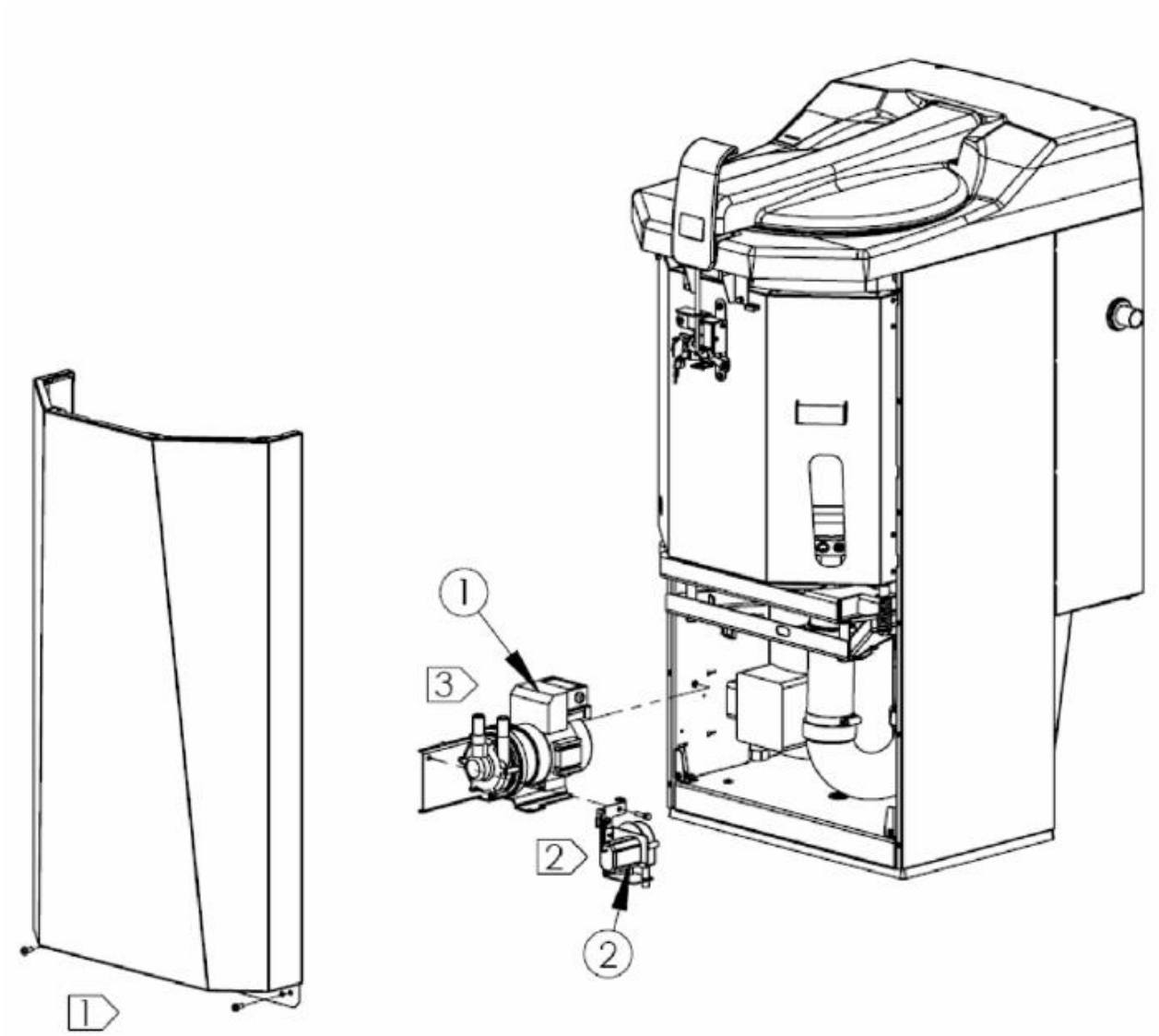

Item	Part No	Description	Qty
1	901-100226	Pump	1
2	901-107038	Deodoriser Feed sub-assembly (if fitted)	1

Main Pump & Deodoriser Pump Removal Diagram



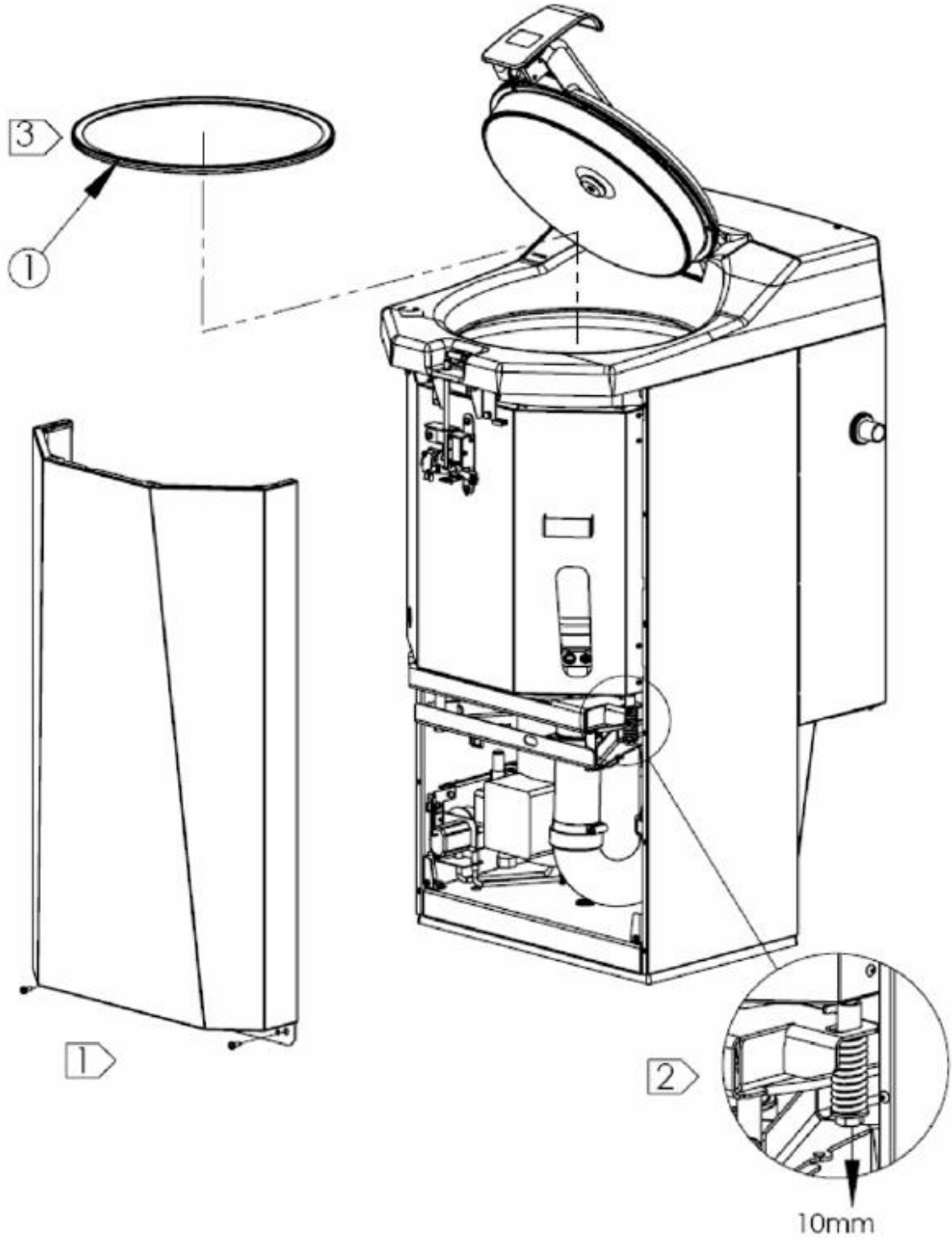

Item	Part No	Description	Qty
1	901-106859	Mark 4 Lid Seal	1

Lid Seal Removal Diagram

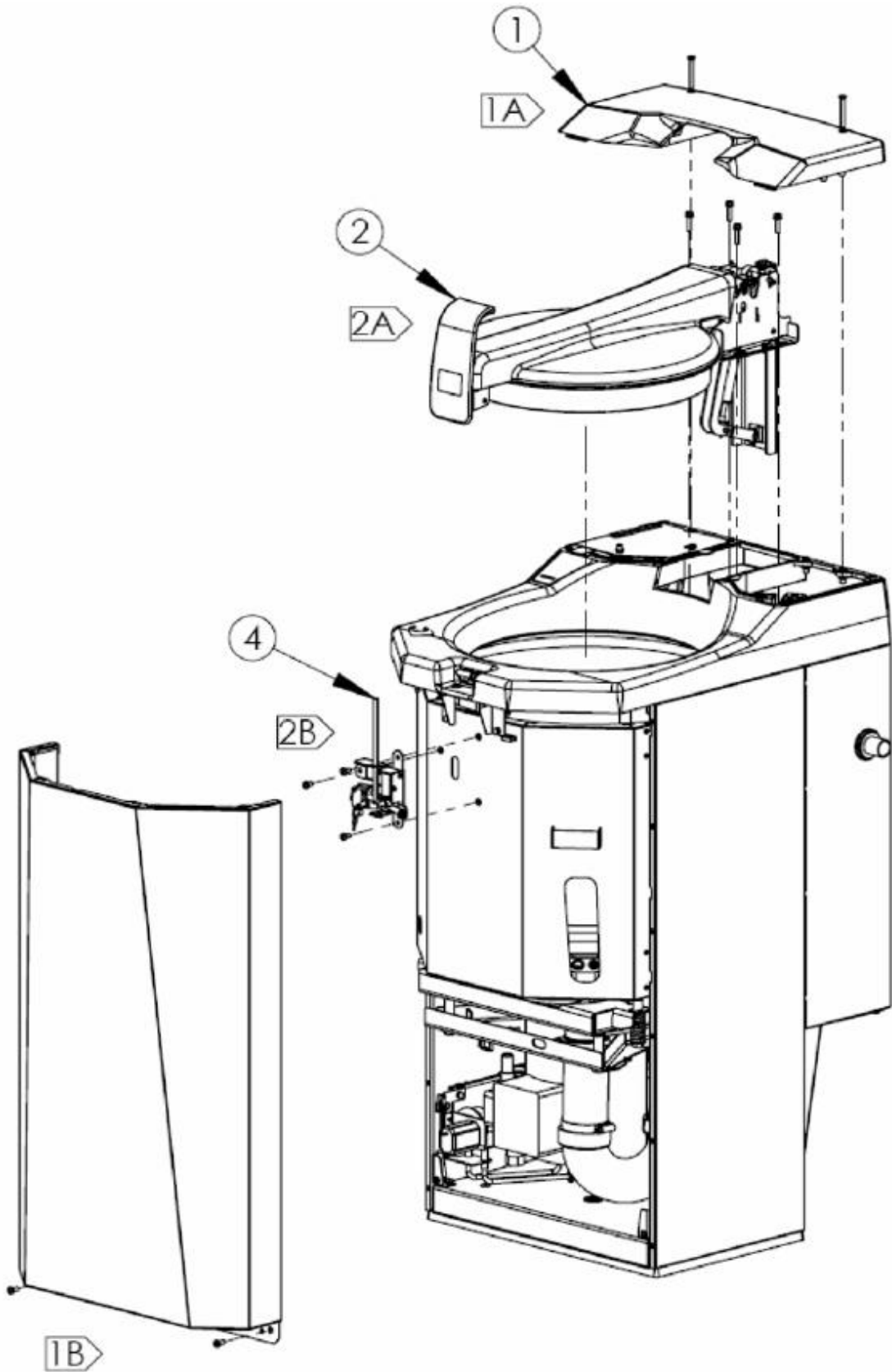

Item	Part No	Description	Qty
1	901-102354	Top Cover	1
2	904-102615	Lid Sub-assembly	1
4	901-103306	Latch Interlock Sub-assembly	1

Lid Sub-assembly & Interlock Removal Diagram

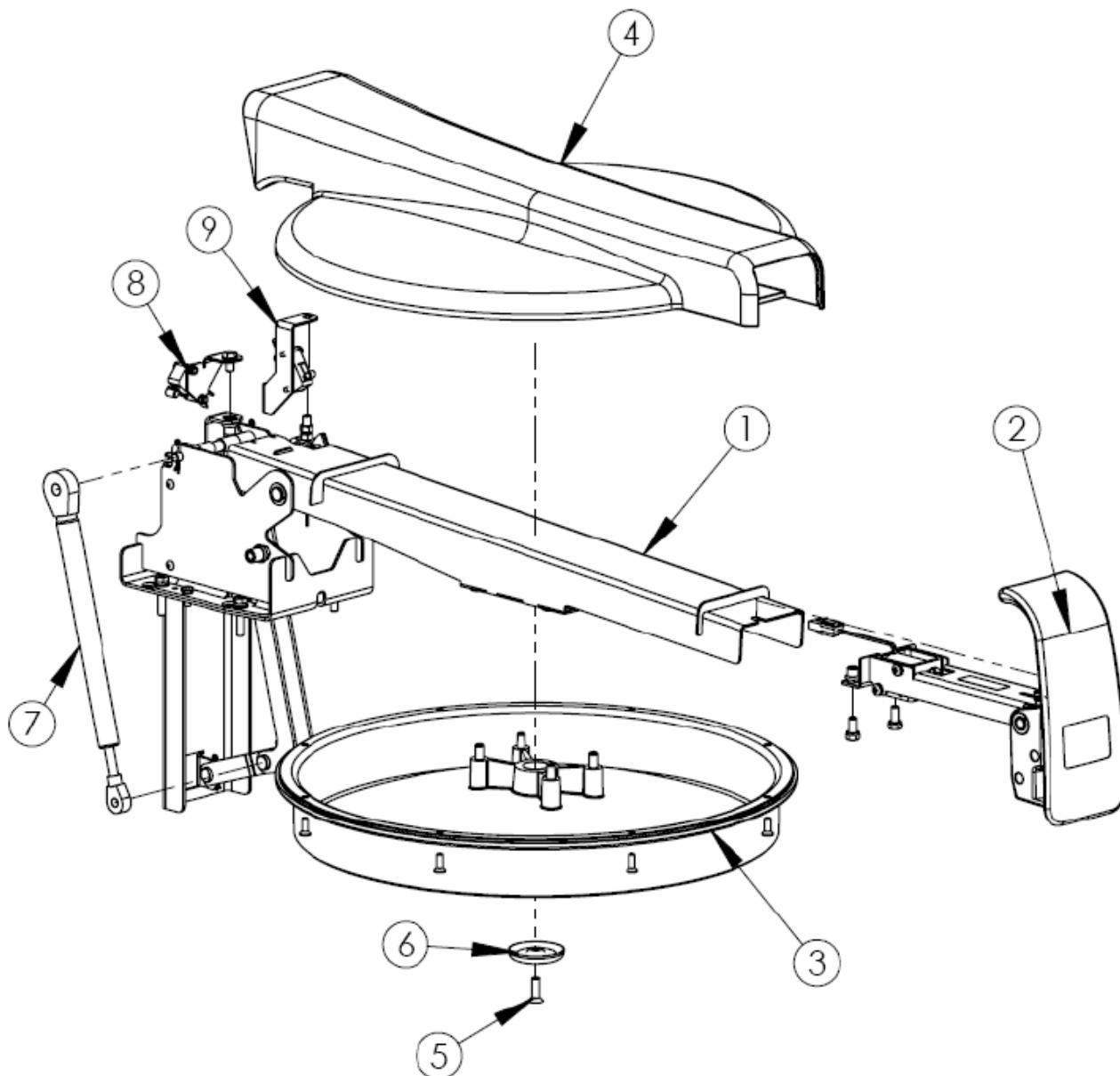

Item	Part No	Description	Qty
1	901-102638	Lid Arm & Hinge Sub-assembly	1
2	902-108615	Handle Assembly (Classic+)	1
3	901-100317	Lid	1
4	901-102353	Lid Cover Moulding	1
5	900-013522	Screw M5 x 16mm Socket Countersunk Head	1
6	900-013486	Vent	1
7	900-013706	Gas Spring	1
8	900-003940	Microswitch	1
9	900-030183	Microswitch	1

**Lid Sub-assembly Servicing Diagram**

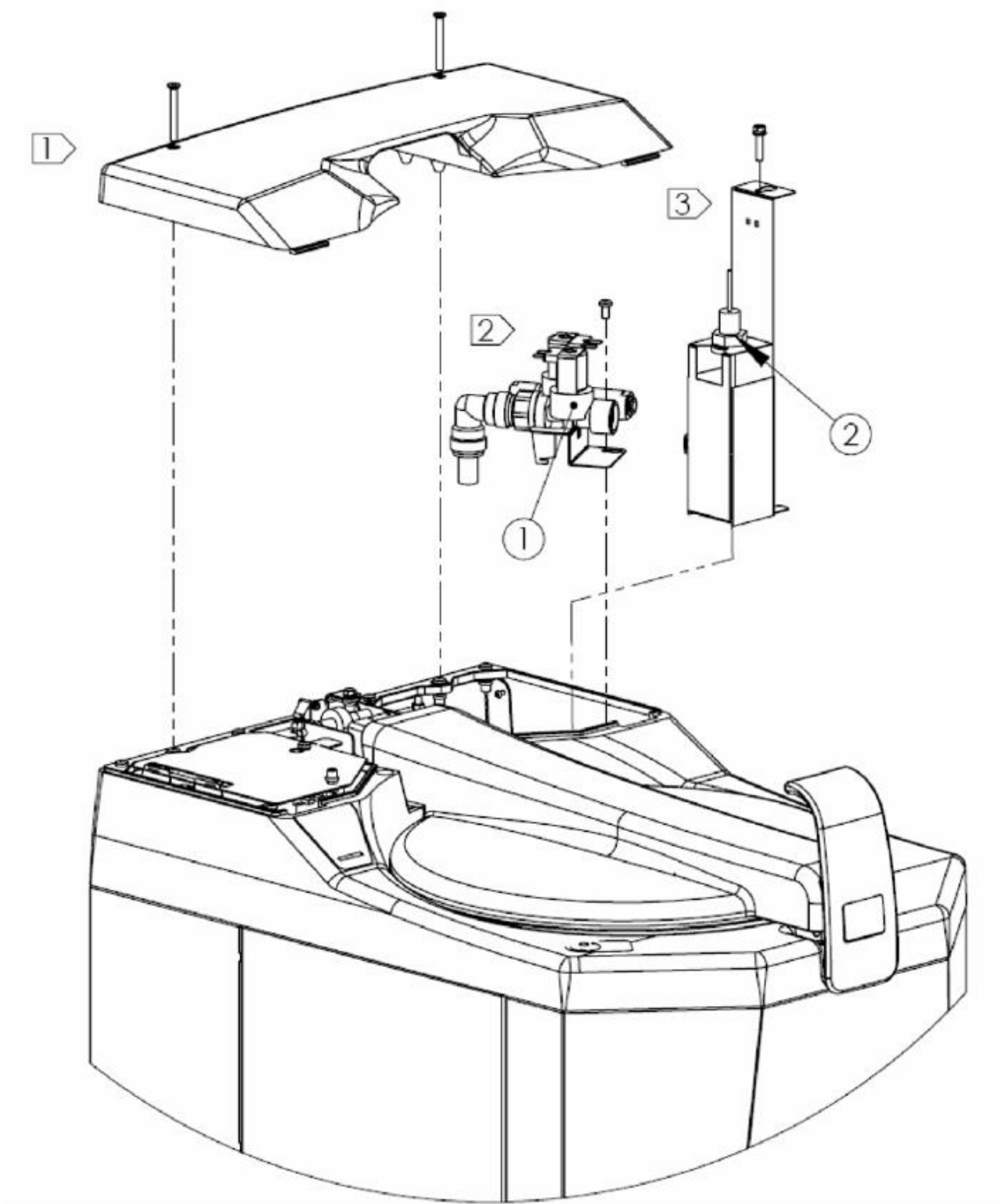

Item	Part No	Description	Qty
1	901-105058	Twin Solenoid Valve Sub-assemblies	1
2	902-105117	Level Switch Mounting Sub-assembly	1

Water Control Removal Diagram

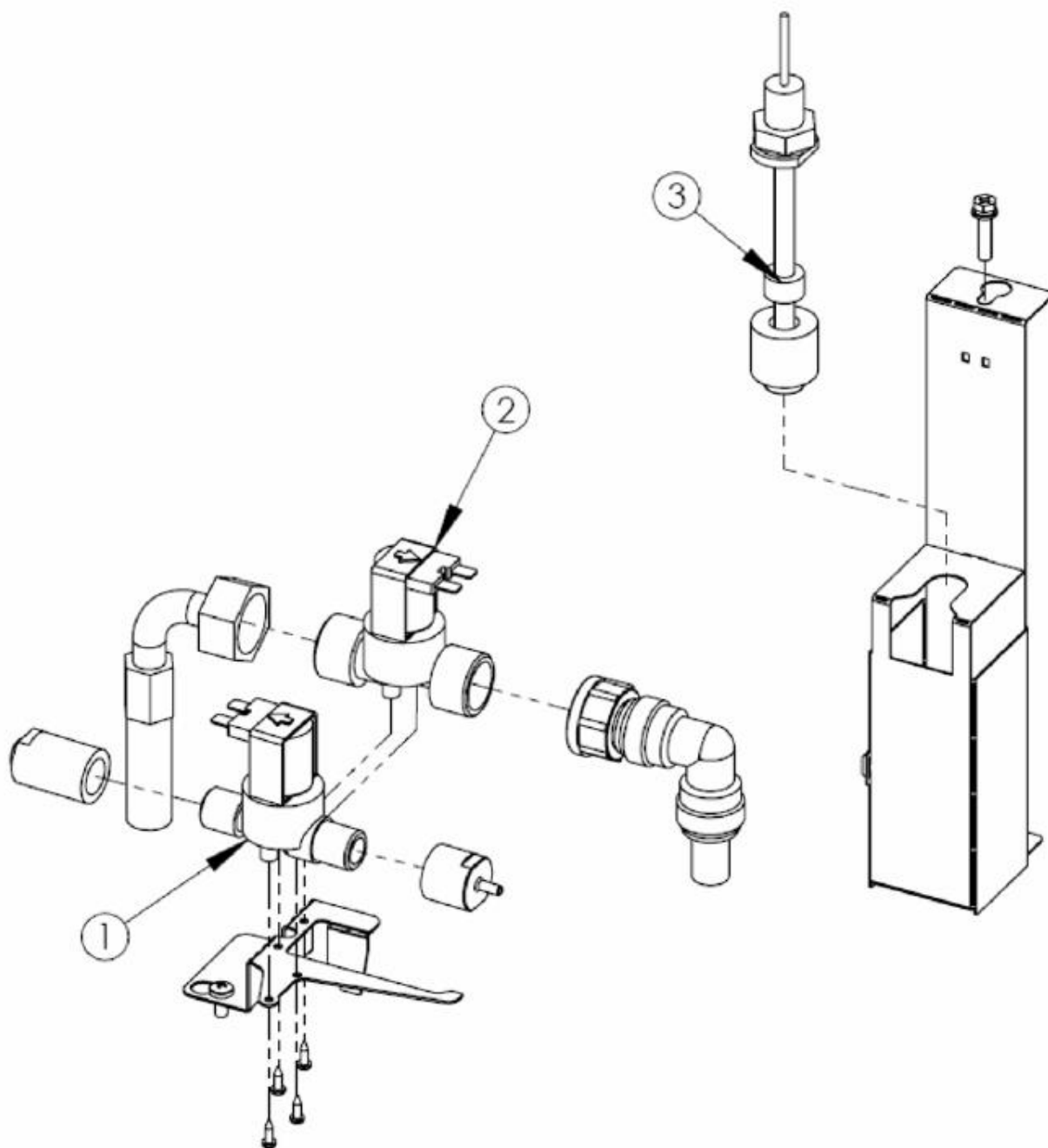

Item	Part No	Description	Qty
1	901-103786	Solenoid Valve Invensys V18, 24V, 3/8" BSP	1
2	901-105709	Solenoid Valve Invensys 24V DC 3/4" BSP	1
3	902-102108	Float Switch Vertically Mounted	1

**Water Control Servicing Diagram**

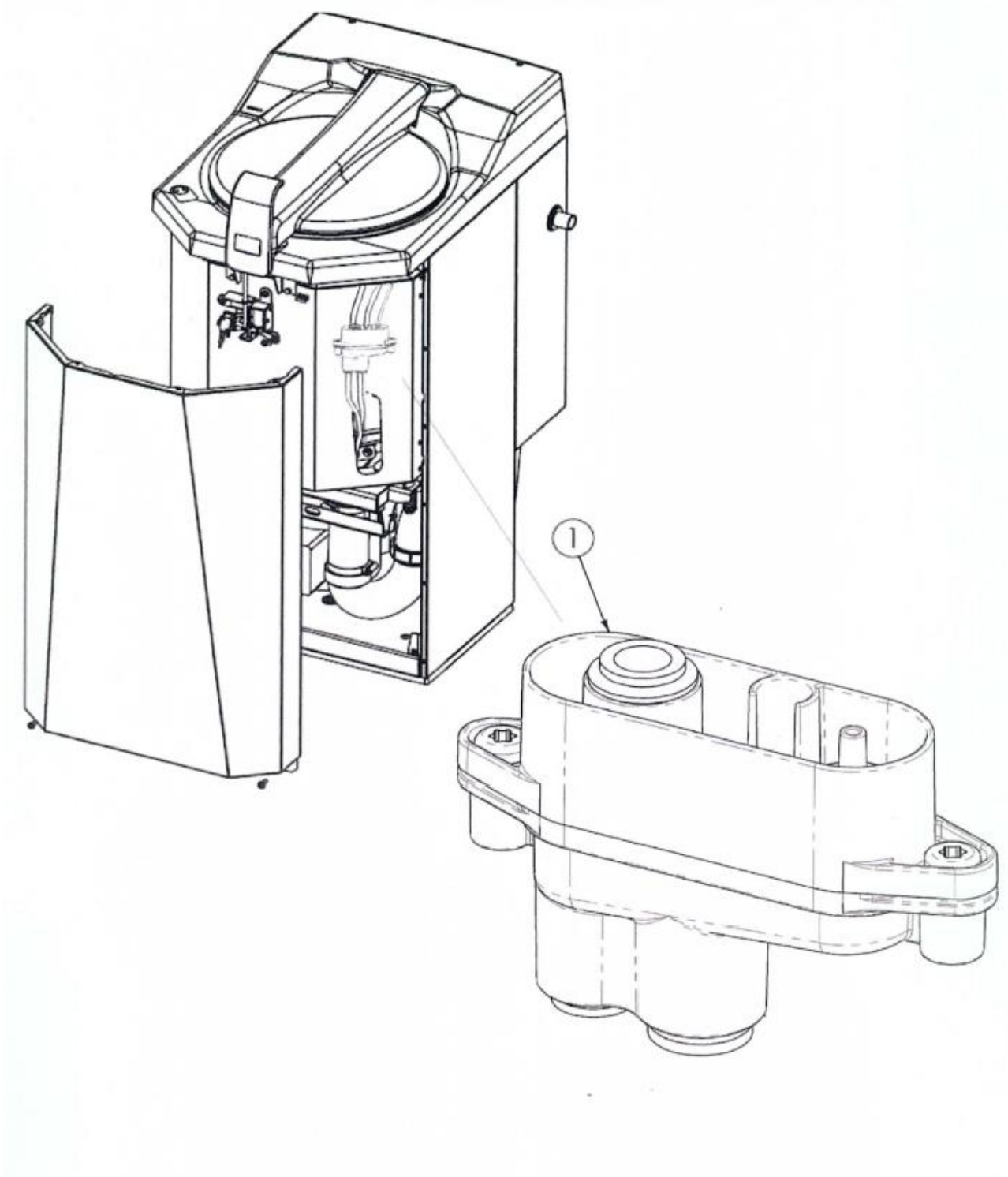

Item	Part No	Description	Qty
1	901-110425	Manifold	1

Plumbing Servicing Diagram



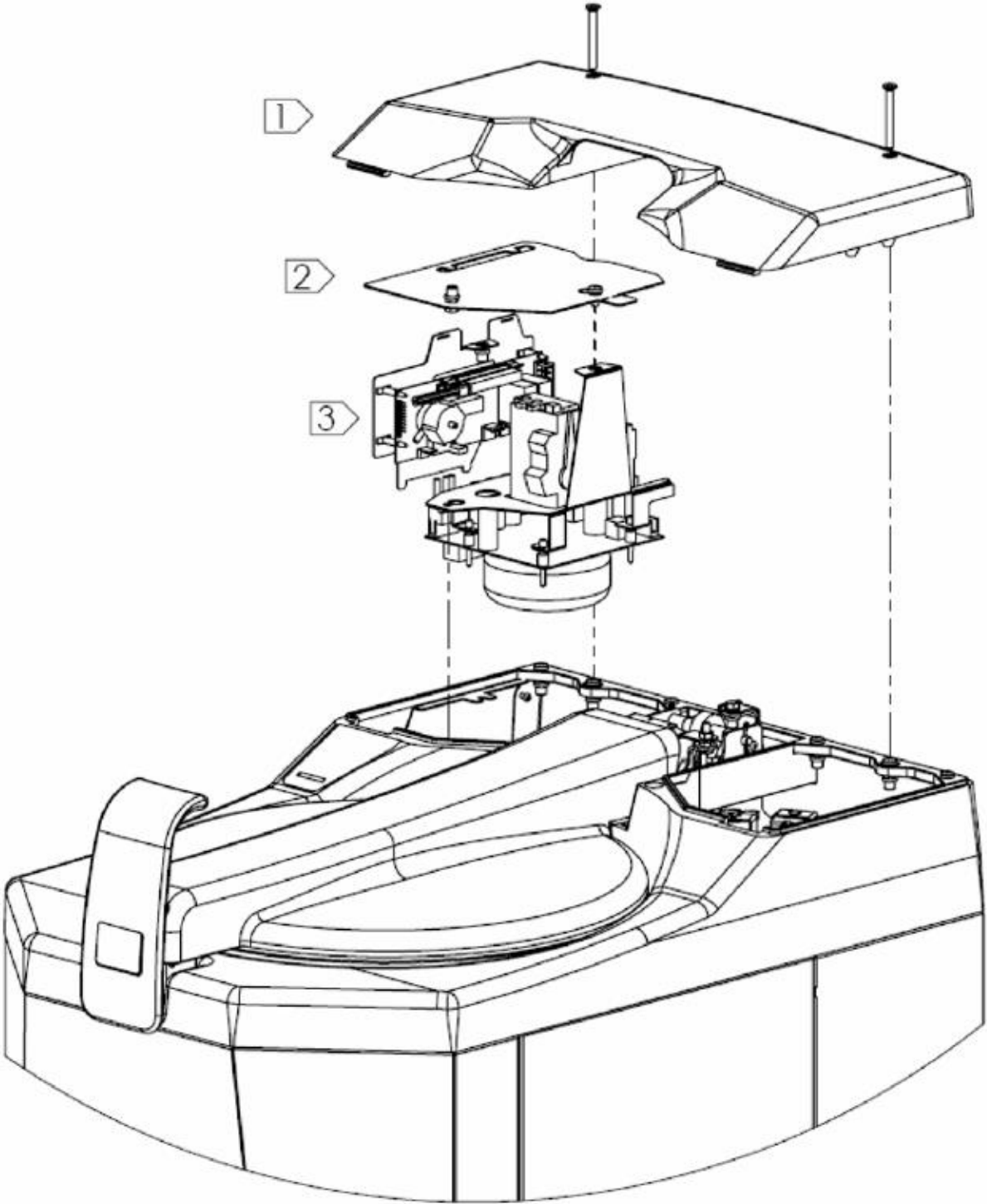

Control Gear Removal Diagram

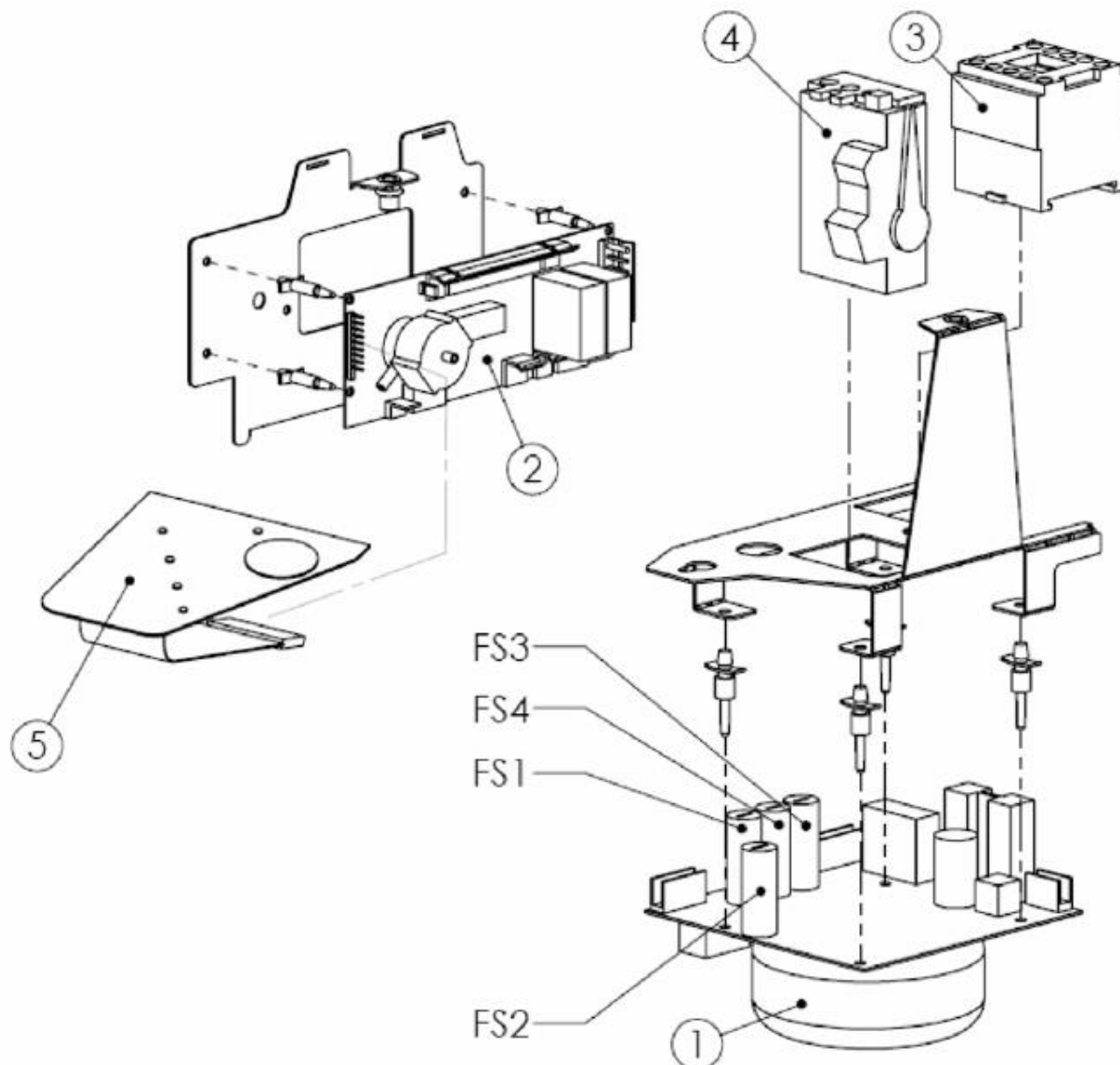

Item	Part No	Description	Qty
1	901-102110	Power Board	1
2	901-107720	PCB Sub-assembly	1
	902-104000	PCB Logic Board (Classic+)	
3	900-030209	Contactor	1
4	902-030154	Overload Device 4.0-6.2 (Classic+ Single Phase)	1
	904-030154	Overload Device 1.2-1.9 (Classic+ 3 Phase)	
5	902-103278	Membrane (Classic+)	1
	FS1	Fuse 2 Amp	1
	FS2	Fuse 2.5 Amp	1
	FS3	Fuse 2 Amp	1
	FS4	Fuse 2 Amp	1

## Control Gear Servicing Diagram



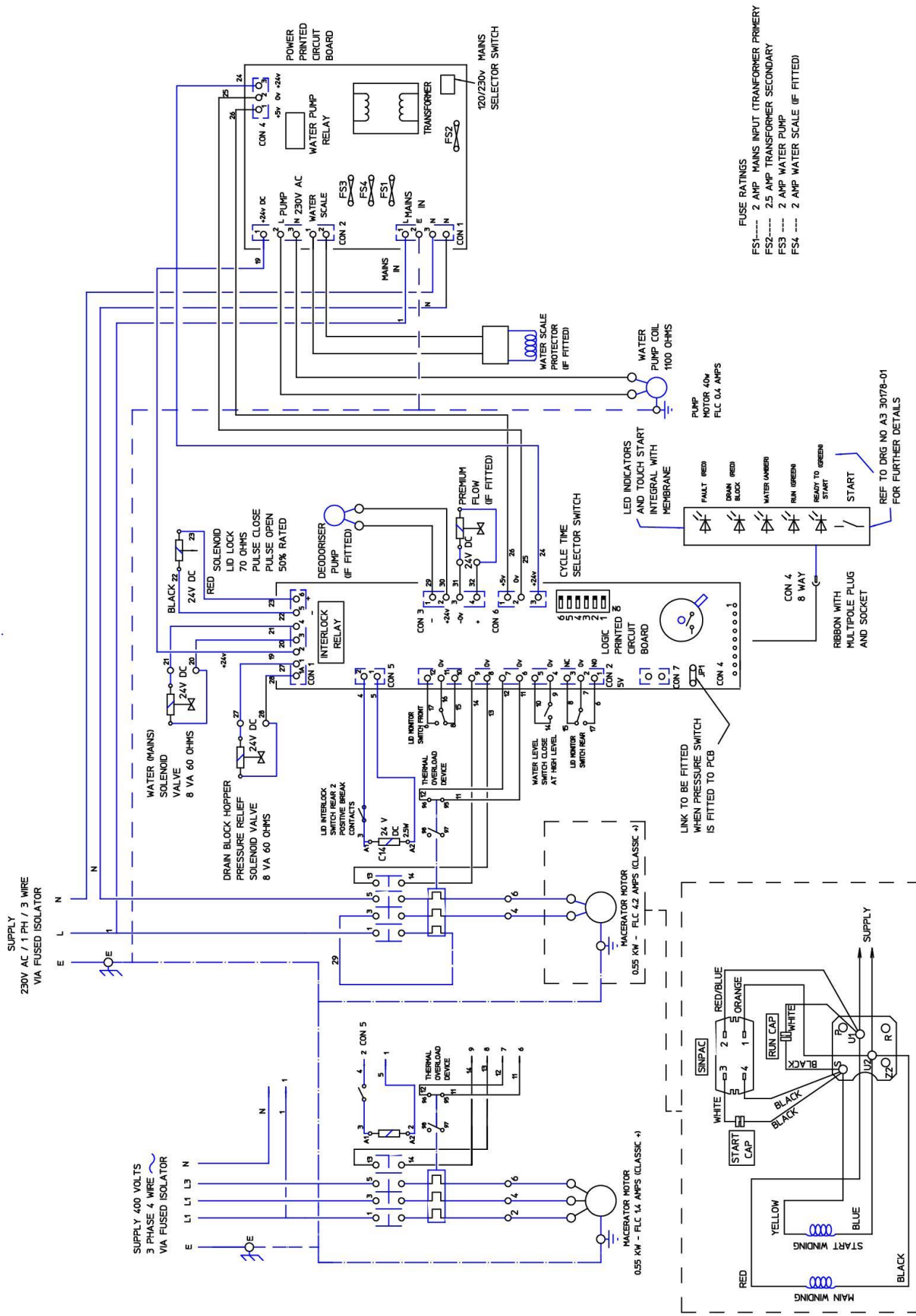

Wiring Diagram



## 6. Fault Finding & Troubleshooting



## Functional Problems



**Electrically isolate the machine before any maintenance**



**Maintenance should only be performed by qualified personnel**

Always check the indicator lights on the machine before calling maintenance staff, as simple remedies may work.

Problem	Possible Causes / Resolution
Machine is not clean internally after use	Lack of water or a failure to circulate within the machine. Check that the main water solenoid valve is operating. Make sure that the main isolating valve is open. Is the water isolator service valve in the 'Open' position? Check that the pump is working.
Underside of lid has a deposit after use	Check for foreign matter in the gap of the vent in the centre of the lid. If this is blocked, remove the vent, clean it and replace it. The jet gap must be the same around its circumference. If the problem is with the pump you will require an exchange unit for this part.
Air bubbles in water supply pipe-work	Check that restrictor is fitted for mains applications.
Lid seal is leaking	Check that the lid seal sits centrally on the lid gasket. Adjust and rectify, before making any adjustments to the latch mechanism. Remove any scum that has accumulated around the lid/hopper seal area.
Unable to open lid	Power failure. A solenoid on the latch mechanism locks the lid. The lid cannot be opened until power is restored. The gas spring has not operated. Inspect and replace if necessary. The handle solenoid latch has not withdrawn. Check the operation of the latch and replace as necessary
Unable to close lid	Handle roller does not engage the striker. Adjust the mechanism by rotating the screw on the underside of the handle assembly, clockwise to ease the clamping force, anti-clockwise to increase the clamping force.
Internal water leakage	The Pulveriser or Pump mechanical seal is leaking. Fit a new mechanical seal in the main assembly, or if the pump is leaking, exchange this for a new part. The plumbing is leaking. Investigate where the leakage originates and rectify the problem. Damaged Hopper Seal. Replace the lid seal, ensuring that the new seal fits correctly.





## Operational Indicators



Indicator Panel Chart

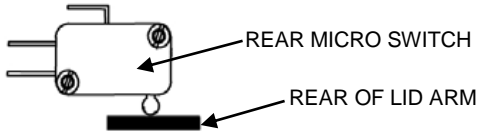
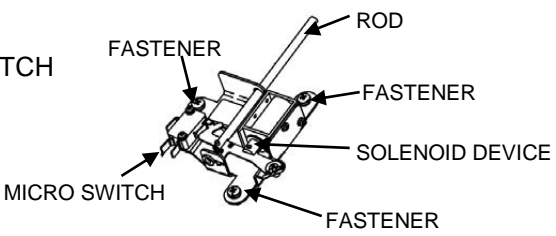

	Start Light (Green)	Operation Cycle (Green)	Low Water (Amber)	Drain Block (Red)	Fault (Red)	Indicates
Normal Mode	ON					Power on, machine ready to run
		ON				Normal running mode
			FLASHING			Cistern replenishing (water solenoid energised).
Fault Mode	FLASHING					Lid latch miss-lock
	FLASHING				ON	Lid latch miss-lock (after 3 attempts).
	FLASHING	FLASHING			ON	Safety monitor circuit malfunction
	FLASHING	FLASHING	FLASHING		ON	Contactors circuit fault
		ON			FLASHING	Overload trip.
		ON		ON		Drain block.
			ON		ON	Cistern fails to replenish with water after 180 seconds.
			FLASHING		ON	Water level fails to drop after 20 seconds
						No indicators illuminated

## Troubleshooting

Problem		Possible Causes / Resolution
1.	Lid latch mis-lock 	Lid latch not correctly fastened.
2.	Lid latch mis-lock (after 3 attempts). 	Lid latch not correctly fastened.  Note - Occurs after three attempts to start the machine in a misslock Condition. Make sure that the lid handle latch is correctly fastened and adjusted if required.
3.	Safety monitor circuit malfunction 	<p>Malfunction found during initial startup procedure:</p> <p>Lid latch not operating. Check electrical operation of rear micro switch and lid latch micro switch for problem</p> <p>Fault at start of cycle. (0 - 1.5 seconds):</p> <p>Lid arm rear micro monitoring switch not operating. Check/adjust position.</p> <p>FIG 7 SWITCH </p> <p>Check/adjust position of solenoid device/micro switch/latch mounting plate. Replace /adjust as required. Check wiring connections.</p> <p>FIG 8 LATCH </p> <p>Machine stops during cycle.</p> <p>Loose micro switch or poor connections. Lid arm rear micro switch opens during cycle, check micro switch and connections.</p> <p>Adjust as required.</p>
4.	Contactor circuit fault 	Main contactor fault.  Check contactor connections, replace contactor if necessary.
5.	Overload trip. 	Motor has tripped out on overload, probably jammed:  Switch off at isolator and remove the obstruction from the hopper.

6.	<p>Drain block.</p> 	<p>Pressure in Hopper:</p> <p>Blockage in Pulveriser exit or drain. Investigate the cause and clear the blockage.</p> <p>Incorrect installation, pipe size, or position of waste pipework. 50mm minimum.</p> <p>Non return/in line valves not operating correctly. Clean or replace as required.</p> <p><b>Never use a reactive chemical drain block clearer within the machine as it will damage the seals.</b></p>
7.	<p>Cistern fails to replenish with water after 180 seconds.</p> 	<p>Lack of water in cistern:</p> <p>Check that the mains inlet valve is open.</p> <p>Check that there is sufficient water pressure.</p> <p>Check and clean the inlet solenoid filter.</p> <p>Check solenoid valve is operating. Replace if required.</p>
8.	<p>Water level fails to drop after 20 seconds</p> 	<p>Pump not operating or level sensor problem:</p> <p>Check the pump and replace if faulty.</p> <p>Check the cistern level switch and replace if faulty.</p>
9.	<p>No indicators illuminated</p>	<p>Power failure</p> <p>No power to machine.</p> <p>Check indicator membrane is connected properly.</p> <p>Check fuses / electrical connections.</p>







[www.haigh.co.uk](http://www.haigh.co.uk)

It is the policy of our company to continually improve our products and accordingly we reserve the right to alter specifications and appearance without notice.

**The Haigh Engineering Company Limited**

Alton Road, Ross-on-Wye, Herefordshire HR9 5NG UK

Tel: +44 (0) 1989 763131

Fax: +44 (0) 1989 768777

[info@haigh.co.uk](mailto:info@haigh.co.uk)

