

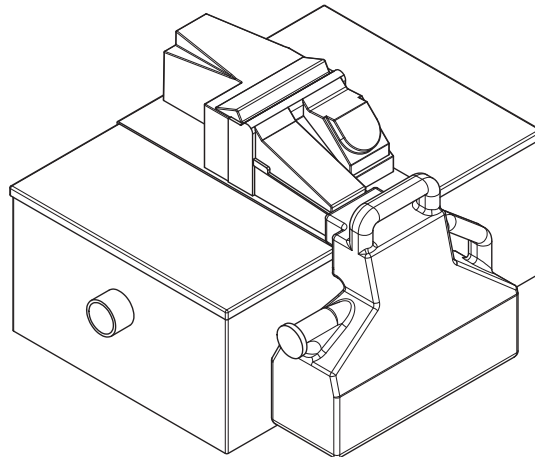

Installation & Operation Instructions For Big Dipper 40000 Series Internal Strainer (IS) Units

Models W-200-IS, W-250-IS, W-350-IS and W-500-IS
(Including 230 VAC Units)



** Please consult Thermaco, Inc. for specific models tested, certified and/or listed by these organizations.*

Copyright ©2015 Big Dipper® Thermaco, Inc. • P.O. Box 2548 • Asheboro, NC 27204
Toll Free: (800) 633-4204 • V: (336) 629-4651 • F: (336) 626-5739
info@thermaco.com • www.big-dipper.com

Table of Contents

IS System Overview3

IS System Maintenance4

IS Digital Control Operation5

IS System Troubleshooting7

How To Reverse IS System Operation8

Plumbing Installation9

Vented Flow Control Installation11

Electrical Installation12

IS System Wiring Diagram13

IS Component Identification14

IS Replacement Parts16

Limited Warranty17

Big Dipper Internal Strainer System Overview

The **Thermaco, Inc. Big Dipper[®]** Automatic Grease and Oils Removal System removes free-floating grease & oils from kitchen drain water flows. As most food service facility managers already know, grease buildup within a building's plumbing drainage system is a major cause of problems due to drain line blockages. These problems jeopardize normal operations as well as create health and safety hazards within the facility itself.

The proper installation of a Big Dipper System can reduce or eliminate grease problems. Use of the Big Dipper assures minimization and/or elimination of costly sewer surcharges and fines through efficient separation and removal of free-floating grease & oils. In addition, the Big Dipper also helps reduce or eliminate pumping and disposal costs associated with conventional grease separators or interceptors. The recovered grease & oils are substantially water-free and are suitable for recycling by local rendering and/or biodiesel companies.

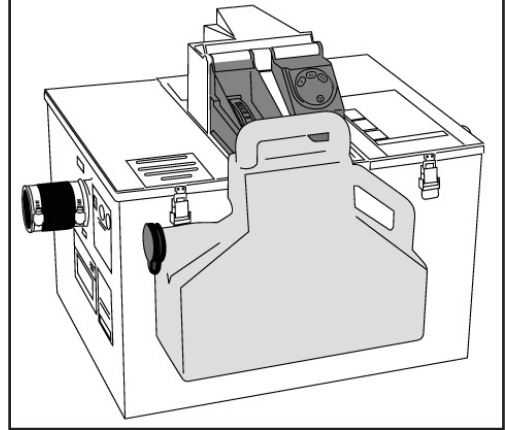

The Big Dipper system is an automatic, self-cleaning device. As greasy kitchen effluent drains from kitchen fixtures, the unit contains the grease & oils. These separate from the effluent and rise to the surface of the separator tank. The unit automatically skims the contained grease & oils and transfers the grease & oils to a collection container. A digital control maintains the self cleaning operation, activating the skimming wheel periodically based on the setting chosen. Only the "cleaned" water exits the unit and flows into the facility drain lines. The Big Dipper IS automatic systems operate most efficiently when servicing single fixtures such as a 1 to 3-compartment sink or a pre-rinse station.

The Big Dipper system's compact footprint allows installation directly at the source where grease problems originate. The system design also allows easy maintenance and operation requiring only a minimal amount of daily and weekly maintenance to maintain peak operating performance.

The Big Dipper system design allows for maximum installation flexibility. Reversing the system operation is as simple as rotating the cover assembly of the unit.

Hydromechanical grease interceptors*, grease separators, automatic recovery units, grease removal devices and other similar plumbing devices receiving kitchen flows from sinks, floor drains, woks and other food bearing sources may generate odors. There are many factors influencing odor evolution and dissemination. These include room ventilation, kitchen menu, ambient temperatures, ware washing practices, grease/oil input, daily input fluid volume, sanitizers, installation plumbing design and product maintenance/upkeep. Odors are usually prevented by good area ventilation, frequent fluid inputs, good product maintenance practices and proper product installation. Additional steps, including aeration, chlorination, improved area ventilation and additional maintenance control, may be needed at some sites.

*Devices formerly referred to as grease traps are now called hydromechanical grease interceptors.



40000 Series

Big Dipper® Internal Strainer (IS) System Maintenance

Big Dipper® Internal Strainer (IS) System Maintenance

- *CAUTION! DISCONNECT POWER TO UNIT BEFORE CLEANING to prevent damage to the unit and personal injury**
- *NOTE: Before energizing unit after cleaning, fill tank with water to protect wipers and heater from damage**

Daily Maintenance:

(A) Empty the clear plastic grease/oils collection container (located beside the unit) prior to its becoming full once each day. The Big Dipper recovers grease and oil virtually water-free so that they can be recycled. The collector container should be washed periodically so as to maintain the easy viewing translucent characteristic of the collector.

(B) The internal strainer basket should be removed and emptied into a garbage container by shaking briskly. Wash the inside and outside surfaces of the strainer after emptying.

Weekly Maintenance:

(A) Check the collection trough and the wiper blades for any solids build-up. Wipe off any accumulated deposits and assure that the wiper blades are clipped in place properly.

(B) Press the Start button (on the bottom of the user interface) momentarily to ensure that the motor and skimming wheel are still operating correctly.

(C) Check the thickness of the grease layer at the top of the unit. There should be no appreciable amount of grease or oil left in the tank immediately after the daily automatic skimming cycle. If there is more than a 1/2" (13 mm) thick layer of grease after the skimming cycle, this indicates a need to increase the skimming time. Increase the digital control settings accordingly until a clean unit appearance is obtained after the automatic skimming cycle. A simple guide is to change to the next higher setting (Light [I] to Moderate [II] or Moderate [II] to Heavy [III]) and run for a period of time until enough grease is being skimmed from the tank.

Quarterly Maintenance:

(A) The internal strainer basket in the unit is designed to remove incidental solids from kitchen drain flows. Over a period of time, sediment consisting of very fine particles may begin to accumulate on the bottom of the unit. If this build-up is allowed to continue, it may eventually block the outlet baffle. To prevent this from occurring, remove the lid and stir the bottom of the unit with a long handled spatula while water is flowing to flush out the sediment. Occasionally drain and clean the unit thoroughly. Properly used, a wet-vac may be appropriate for this purpose.

Digital Control Operation (Default Modes)

Timed Skimming Default

Through the “User Interface” three levels of skimming may be selected in the “default” mode. By selecting one of the skimming buttons – I, II, or III - the skimming cycle (see table below) is activated. The LED associated with the selected button is illuminated continuously as an indicator of the selected skim cycle and as a “power on” indicator. If the skimming level is changed during an active skimming cycle, the next active skim cycle will be at the new setting (The LED associated with the newly selected level will change immediately). If the skimming cycle is changed between active skimming cycles the next skim cycle will be at the new level.

Motor Exercising

For all default mode skimming levels, the motor will be energized for 30 seconds every 9.5 hours. Only the motor will be energized (no heater operation) at these exercising times.

Start Button Operation

Any time the start button is depressed the “time between skims” the digital control goes to its maximum time and operation begins for the selected skim level. After this skimming cycle the normal time delay to the next skim cycle is used (skim cycle resets when the start button is depressed).

Heater Operation

The heater operates under Thermistor control any time the skimmer motor is energized and anytime the liquid temperature drops to 40° F to prevent liquid from freezing. Contact Thermaco for programming alternative heater settings.

Light Setting:
Recommended for Light Grease Output (Small Cafes, Coffee/ Ice Cream shops***)

Moderate Setting:
Recommended for Moderate Grease Output (Quick and Full-Service restaurants***)

Heavy Setting:
Recommended for Heavy Grease Output (Steakhouses, Buffets, Heavy Grease producing sites***)

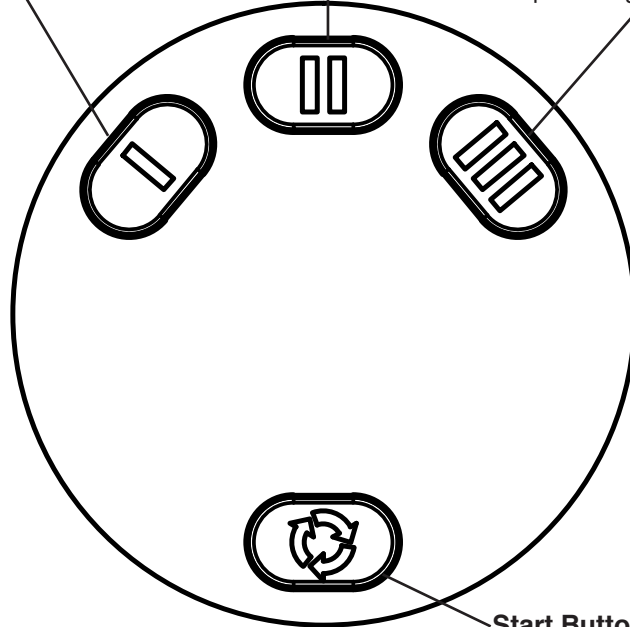

Start Button: Press to begin a cycle early or to test operation..

Default Modes - Normal Operation*

Button Selected	Skim Time	Delay Between Skims**
Light (I)	15 Minutes	76 Hours
Moderate (II)	30 Minutes	19 Hours
Heavy (III)	60 Minutes	19 Hours

* For Extreme Conditions see next page.

** Delay between Skims is the time from the start of the 1st skim to the start of the next skim.

*** Only examples, actual mode needed will vary depending upon menu, warewashing procedures, etc.

Digital Control Operation (Extreme Modes)

Extreme Operation

For Food Service Operations which produce more grease and need additional run-time, the 40000 Series Big Dipper provides additional modes for extreme operation. In order to access these modes:

1. Remove power from CLA by unplugging unit or lifting it to disengage the safety switch (found on underside of the back of assembly).
2. Reapply power while holding down the Heavy Mode (III) Button.
3. The button (III) will blink temporarily, indicating which operation level has been selected.
4. Select desired mode at skim times/frequencies listed below.

Extreme Modes

Button Selected	Skim Time	Delay Between Skims*
Light (I)	90 Minutes	19 Hours
Moderate (II)	120 Minutes	19 Hours
Heavy (III)	120 Minutes	9.5 Hours

* Delay between Skims is the time from the start of the 1st skim to the start of the next skim.

To return to Default Modes, follow the instructions above, but press the Light Mode (I) Button instead of the Heavy Mode (III) Button. The Light Mode (I) Button will temporarily blink to indicate this operational level has been selected.

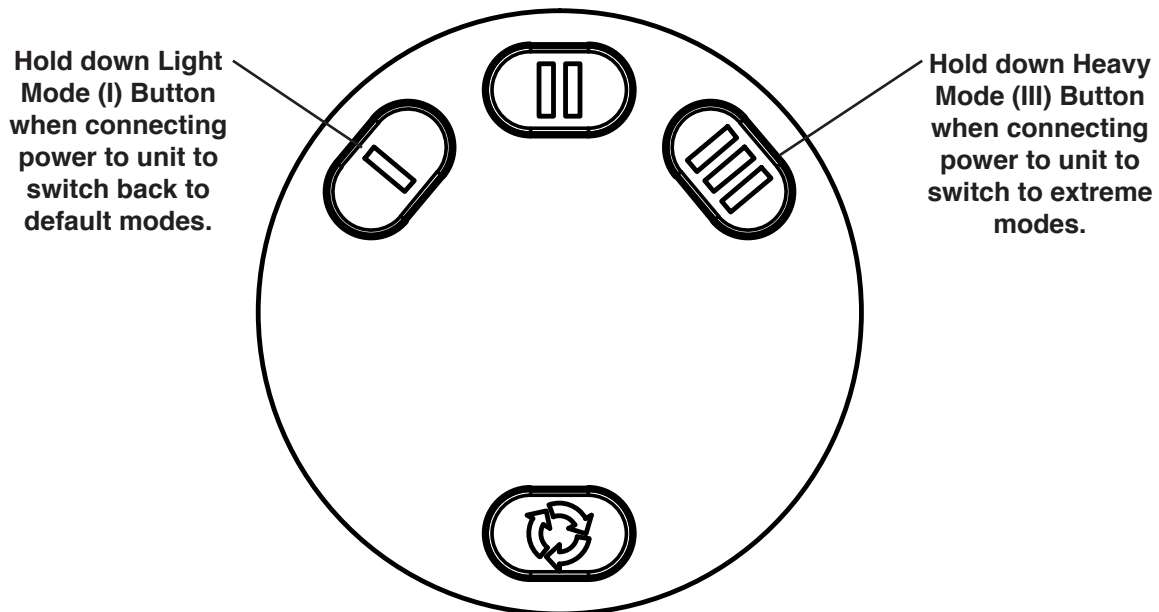

Big Dipper unit overflows

(1) Check to see that the outlet pipe is not reduced to a smaller size, the outlet piping is vented, has as few 90 degree outlet turns as possible, and that no “P” trap is installed on the outlet. Re-plumb the piping, if necessary. Check outlet piping for clogs. Have a plumber clean the line, if necessary.

(2) Make sure that the solids strainer is in place and emptied daily.

(3) Check the bottom of the grease chamber for excessive solids and silt buildup which may be blocking the outlet baffle. Disconnect the power and use a long handled spatula or similar instrument to stir the bottom while water flows through the unit. If necessary, drain and clean the sediment from the unit. To prevent recurrence, schedule this cleaning to be done on a regular basis (properly used, a wet vac may be appropriate for cleaning sediment from the bottom of the unit).

(4) Make sure the flow rate to the unit does not exceed the maximum flow rate, which is shown on the nameplate. If necessary, have a plumber install an approved flow control to restrict the inlet flow to the specified level or install a properly sized Big Dipper for the application.

Excessive water observed in the grease collection container

(1) Check Digital Control for excessive “on” time. Unit will pick up incidental water after all grease is removed. If necessary, reduce the digital control setting (i.e. Moderate [II] to Light [I]) until no water is observed in the grease collection container.

(2) Make sure that the water flow to the unit does not exceed the rated flow and there are no drain line clogs downstream from the unit.

No grease is collected in the container

(1) Check to be sure the power is on and the correct setting is chosen. One of the setting buttons should be illuminated. If none of the setting buttons are illuminated, the unit is not powered.

(2) Lift the sump cover and clean away any buildup that may be present on the wiper blades or collection trough. Make sure the wiper blade(s) are properly in place on the skimmer wheels. Replace wiper blades when worn or warped.

(3) Press the Start Button on the bottom of the user interface to ensure that the skimming wheel turns.

CAUTION: Keep your hands away from moving parts to avoid possible injury. If the skimmer motor does not come on, the motor assembly may need to be replaced.

(4) Check for congealed grease in the unit. If the Big Dipper’s heating element is not warming the unit, the heating element may need to be replaced.

(5) Some sites do not generate enough grease to be captured by the skimming process. Set Control for minimum operation - Setting [I] for Light Skimming Operation.

Objectionable odor

(1) Make sure grease/oil is being skimmed properly from the unit.

(2) Check Digital Control for excessive “on” time. Unit will pick up incidental water after all grease is removed. If necessary, reduce the digital control setting (i.e. Moderate [II] to Light [I]) until no water is observed in the grease collection container.

(3) If excessive sediment has collected on the bottom of the unit, clean the unit as described in item 3 in “Big Dipper unit overflows.”

(4) Clean the solids strainer and grease collection container more frequently.

(5) Grease interceptors, grease traps, automatic recovery units, grease removal devices and other similar plumbing devices receiving kitchen flows from sinks, floor drains, woks and other food bearing sources may generate odors. There are many factors influencing odor evolution and dissemination. These include room ventilation, kitchen menu, ambient temperatures, ware washing practices, grease/oil input, daily input fluid volume, sanitizers, installation plumbing design and product maintenance/upkeep. Odors are usually prevented by good area ventilation, frequent fluid inputs, good product maintenance practices and proper product installation. Additional steps, including aeration, chlorination, improved area ventilation and additional maintenance control, may be needed at some sites.

How To Reverse Big Dipper[®] IS System Unit Operation

***ALWAYS UNPLUG UNIT BEFORE REMOVING LID**
***SYSTEM WILL NOT OPERATE UNLESS CENTER MODULE IS IN PLACE**

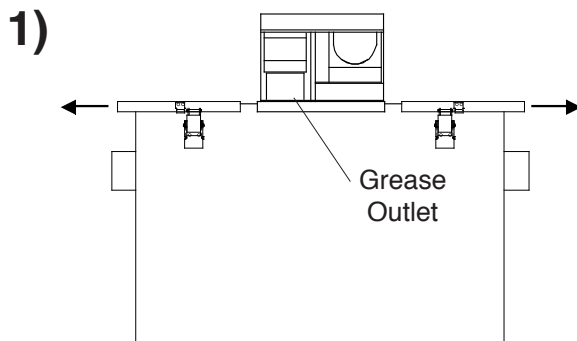

1) Unlatch the Unit lid. Pull the side wings outward.

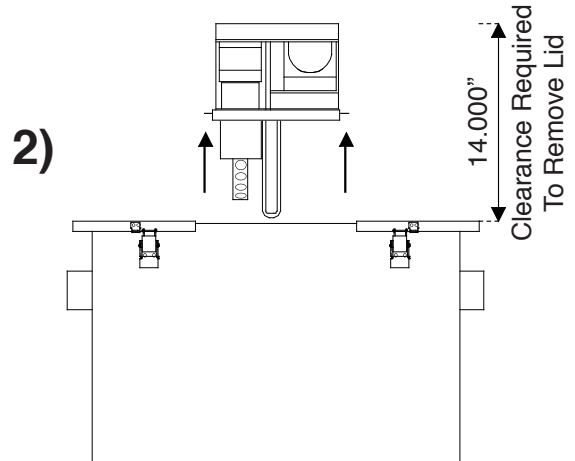

2) Lift the center module up off of the unit, ensuring clearance for the heater.

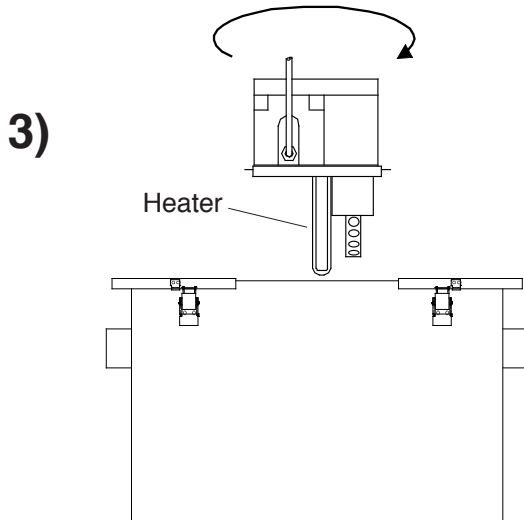

3) Rotate the center module 180°.

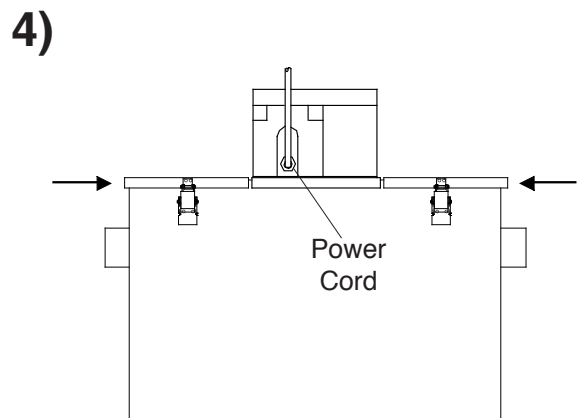

4) Lower the center module back down on top of the unit. Move the two side wings back into place & fasten all latches.



40000 Series

Big Dipper® IS System Plumbing Installation

Big Dipper® IS System Plumbing Installation

Locating the Unit

To minimize grease build-up in piping, a Big Dipper system should be located as close as possible to the fixture it is serving. The system should be visible and easily accessible for maintenance and inspection. The unit must be in a level position. **Be sure to check the Specification Sheet for your model for the exact clearances needed for installation.** If the system is located directly on the floor, the bottom should be sealed to the floor with an approved silicone type sealant. Make sure the height above the Internal Strainer access cover is enough to remove the strainer basket.

Inlet/Outlet Piping

The inlet and outlet piping connections require flexible sleeve pipe couplings. Keep outlet piping as straight as possible. Use only “sweep” connections. Do not reduce the pipe sizing on the outlet piping. Do not install “P” trap on outlet connection of system. (Note: The system already has a internal gas trap)

Flow Controls

Big Dipper systems are equipped with an internal flow control located inside the inlet end of the system. Verify its location and placement prior to connecting the inlet piping.

Fill Unit With Water Before Applying Power

Big Dipper systems, equipped with an electric heating element, MUST be filled with water before energizing the power to the system. Failure to do so may damage the electric heating element. These elements will NOT be replaced under Thermaco’s Warranty.

Venting the Outlet

An outlet vent or approved vacuum breaker of at least 1/2 the diameter of the system’s outlet connection must be present as close as possible to the Big Dipper outlet to prevent possible siphonage problems. Failure to provide a vent for the system voids Thermaco’s Warranty for the system.

For High Head Height Applications Over Six (6) Feet (1.95 m)

Big Dipper systems are equipped with an internal flow regulator located inside the inlet end of the system. Verify its location and placement prior to connecting the inlet piping. If your code requires a vertical type flow regulator, an approved control with a flow rating matching the system’s flow rate should be used. Note: When a Big Dipper is servicing multiple fixtures, some codes require separate flow controls for each fixture. See following page for suggested high head height flow regulation installation.

Do Not Use With Food Grinders, Potato Peelers or Waste Disposal Units

If the system is connected to a Waste Disposal Unit, Garbage Grinder or Potato Peeler, Thermaco’s Warranty will be void.

Note: Drawing for reference only. Equipment must be installed in compliance with all applicable laws, regulations and codes, including plumbing codes. Installation should be performed by a qualified plumber.

Sometimes space restrictions require the installation of Big Dipper units in basement locations where significant head pressure becomes a factor. The **Big Dipper® VFCA Vented Flow Control** module provides an option for use with installations where a significant amount of head pressure is present (greater than 6 ft./1.95 m) or where applicable regulations require vented flow controls. A Vented Flow Control helps reduce problems associated with high head pressure and helps slow the drainwater flow down. The VFCA kit contains an appropriate fitting and flow control orifice.

Flow Control Vent/Air Intake

(Note: Flow Control Vent may be connected to atmosphere vent, facility vent, or code-approved air admittance valve. To be installed above sink flood rim.)

**Drainage Piping
from Kitchen**

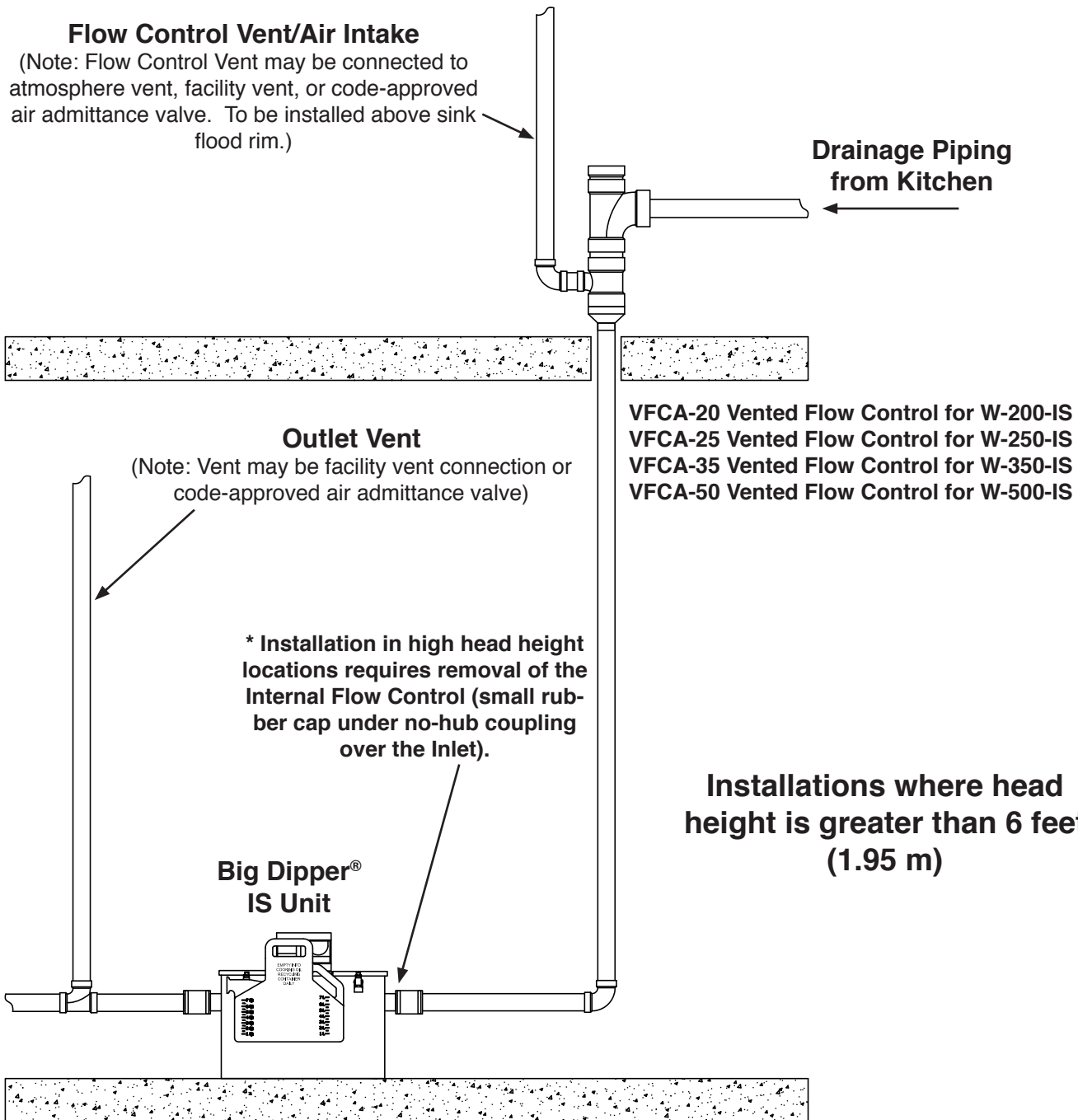

Outlet Vent

(Note: Vent may be facility vent connection or code-approved air admittance valve)

**VFCA-20 Vented Flow Control for W-200-IS
VFCA-25 Vented Flow Control for W-250-IS
VFCA-35 Vented Flow Control for W-350-IS
VFCA-50 Vented Flow Control for W-500-IS**

* Installation in high head height locations requires removal of the Internal Flow Control (small rubber cap under no-hub coupling over the Inlet).

**Big Dipper®
IS Unit**

**Installations where head
height is greater than 6 feet
(1.95 m)**

NOTE: Drawing for reference only. Equipment must be installed in compliance with all applicable laws, regulations and codes, including plumbing codes. Installation should be performed by a qualified plumber.

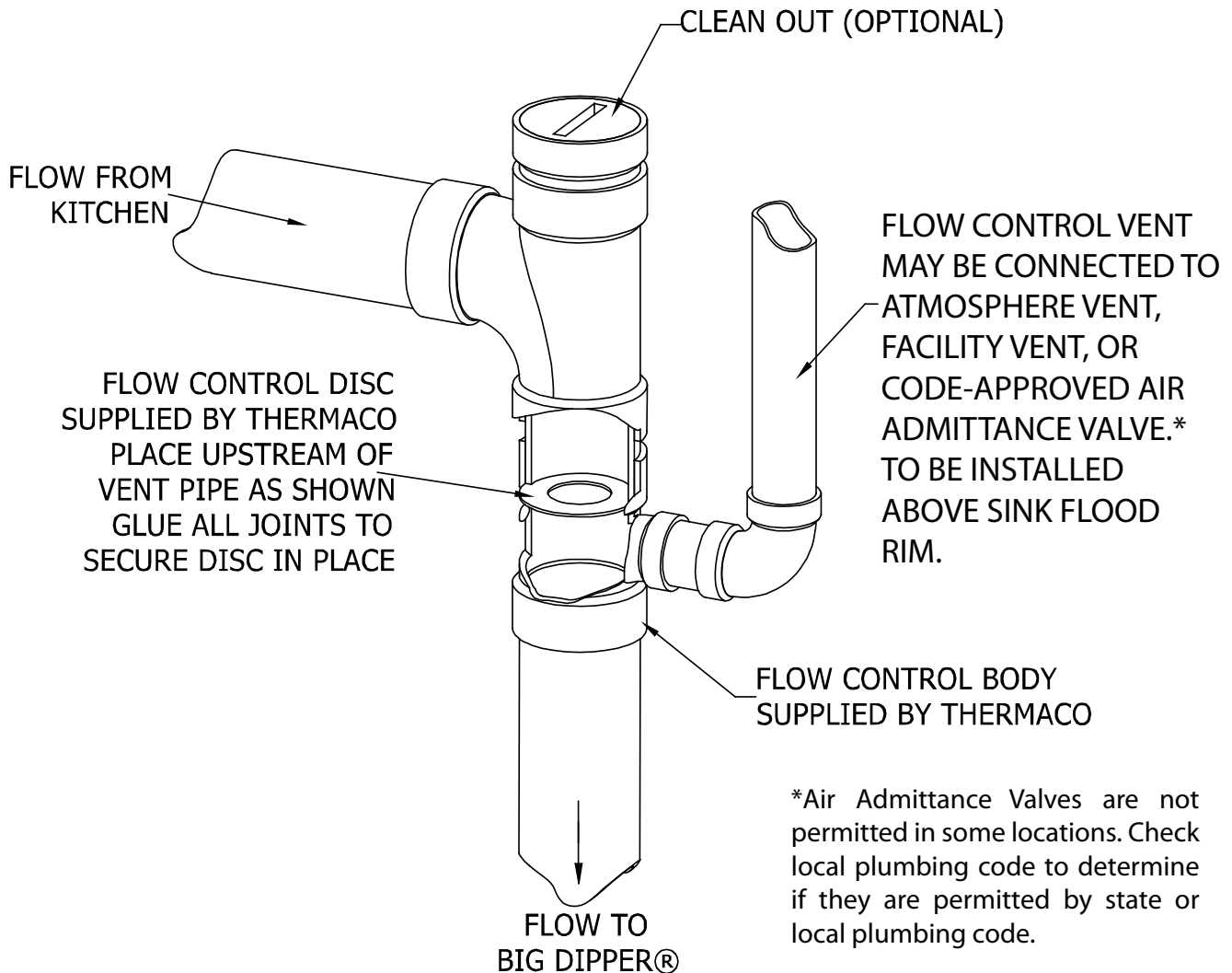

IMPORTANT!

The flow control should be installed after the last fixture as close as possible to the under side of the lowest fixture. If the flow control is installed more than 2 feet below the lowest fixture consult the manufacturer for a more restrictive disc. Remove the rubber flow control from the Big Dipper system.

Note: This equipment must be installed to comply with all applicable national, state, and local plumbing codes for your area. Installation should only be performed by a qualified plumber.

Big Dipper[®] IS System Electrical Installation

Big Dipper Internal Strainer (IS) Models

Big Dipper Internal Strainer Series Models utilize one Push Button Digital Time Controller. The Digital Control is located under the hinged lid of the motor enclosure on top of the lid of Big Dipper (See Digital Control Operation Instructions). **The Big Dipper should only be plugged into a properly grounded 3-prong 115 VAC or 230 VAC outlet.** If possible, the power supply outlet for the Big Dipper should be connected to an electrical circuit controlled by a ground fault circuit breaker.

One of the setting buttons should be illuminated to show the unit is powered. If none of the setting buttons are illuminated, the unit is not powered.

This Big Dipper unit is shipped from the Factory wired for **Simultaneous Operation**. This means the Heater and Motor operate at the same time under digital control. Continuous Heater Operation is where the Heater is active at all times. To switch to alternative heating programming, please contact a Thermaco representative for further instructions.

Note: The Big Dipper unit will not operate when the lid is removed.

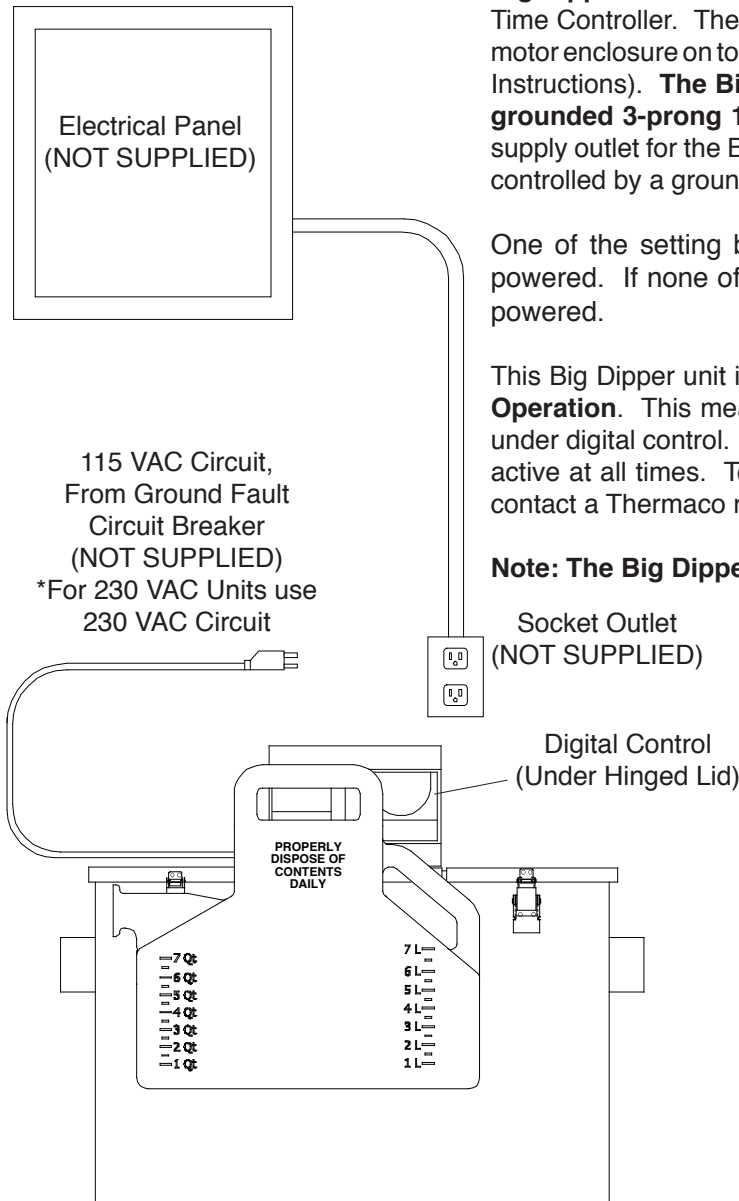

Big Dipper Electrical Requirements

4.5 Amps @ 115 VAC 50/60Hz (520 Watts)

*For 230 VAC Units:

2.3 Amps @ 230 VAC 50/60Hz (520 Watts)

Note:

Digital Control Supplied with system.

Drawing for reference only. Equipment must be installed in compliance with all applicable laws, regulations and codes, including electrical codes.

Installation should be performed by a qualified electrician.

**Wiring Diagram For Big Dipper Models
W-200-IS Through W-500-IS**

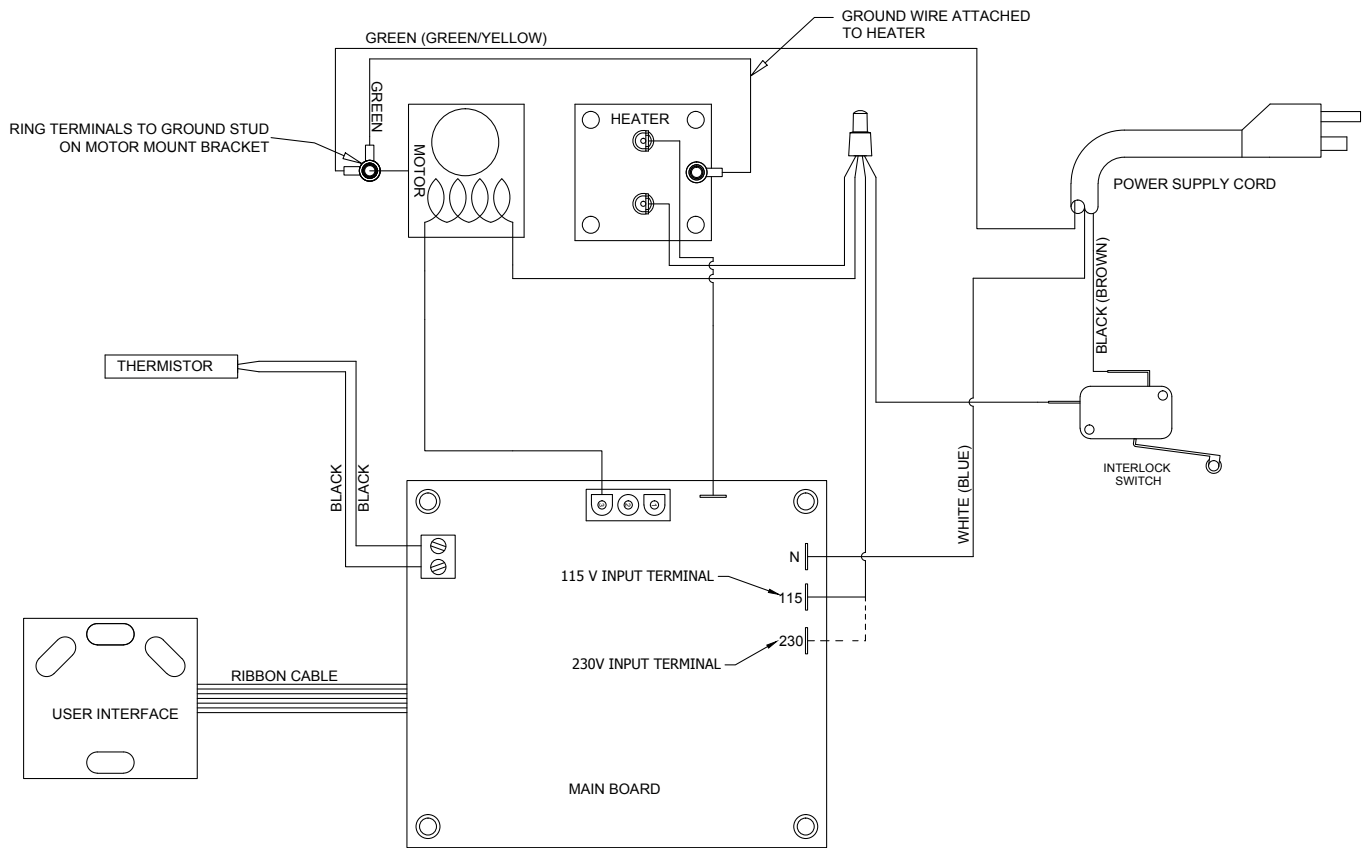

NOTE:

220-240V Units (International Units) have the following wire color changes:
On the POWER SUPPLY CORD:
The Black Wire becomes Brown
The White Wire becomes Blue
The Green Wire becomes Yellow/Green

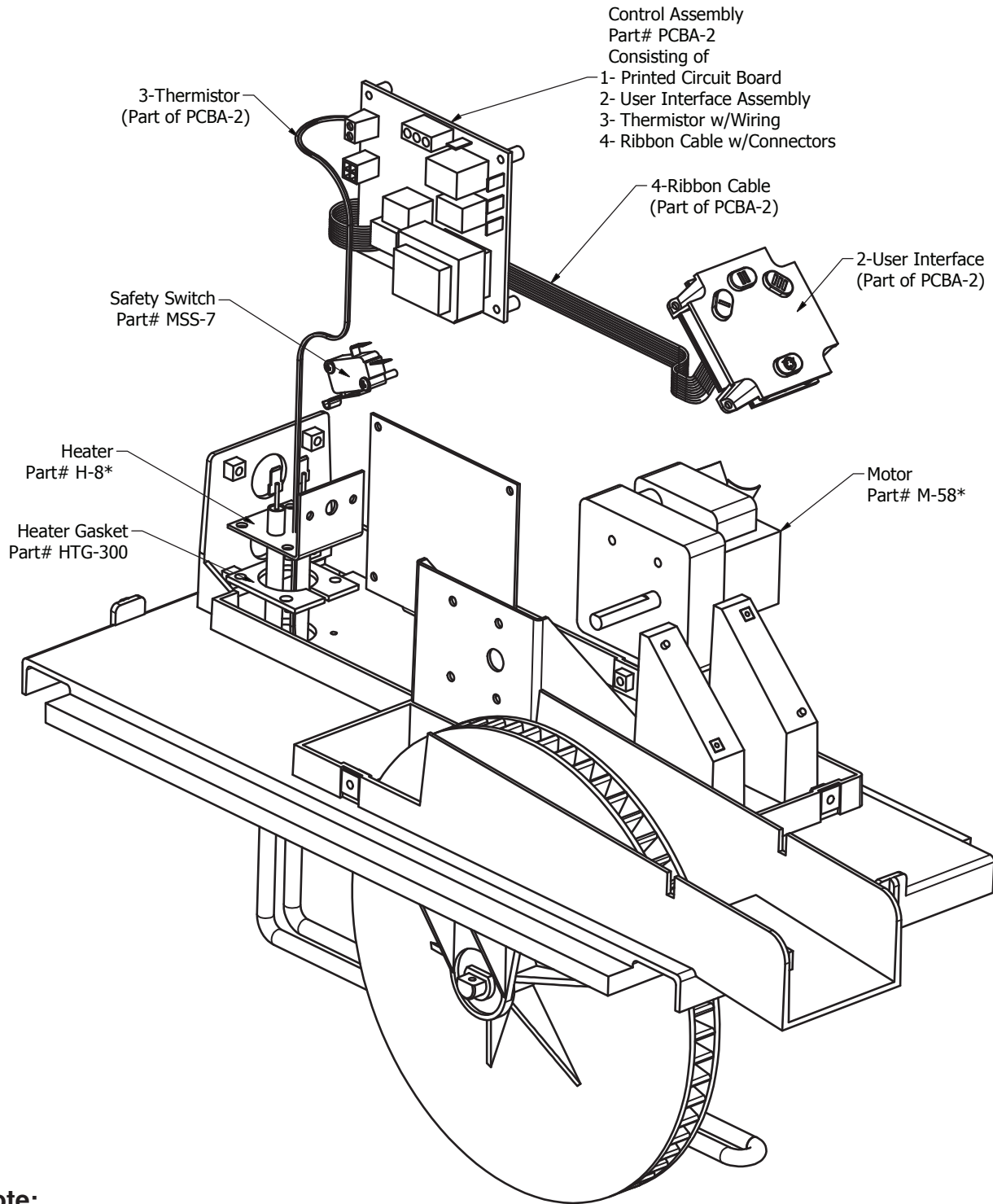

***Note:**
**230 VAC Units use M-58-230
and H-8-230**

Big Dipper[®] IS System Component Identification

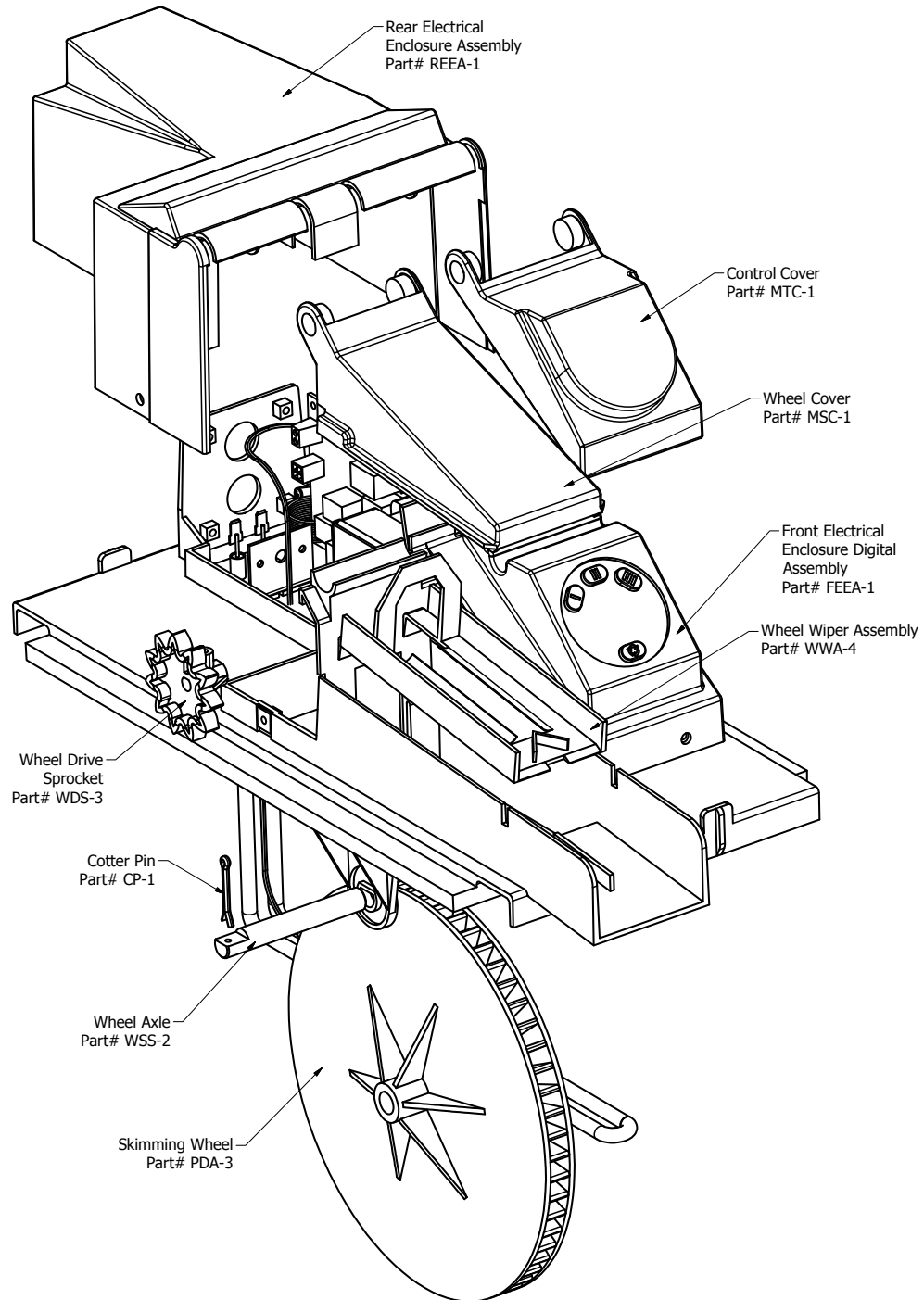

Big Dipper[®] IS System Replacement Parts

SOLIDS STRAINER BASKET

FOR MODEL#
W-200-IS THROUGH W-250-IS
W-350-IS & W-500-IS

USE PART#
ST-21
ST-62

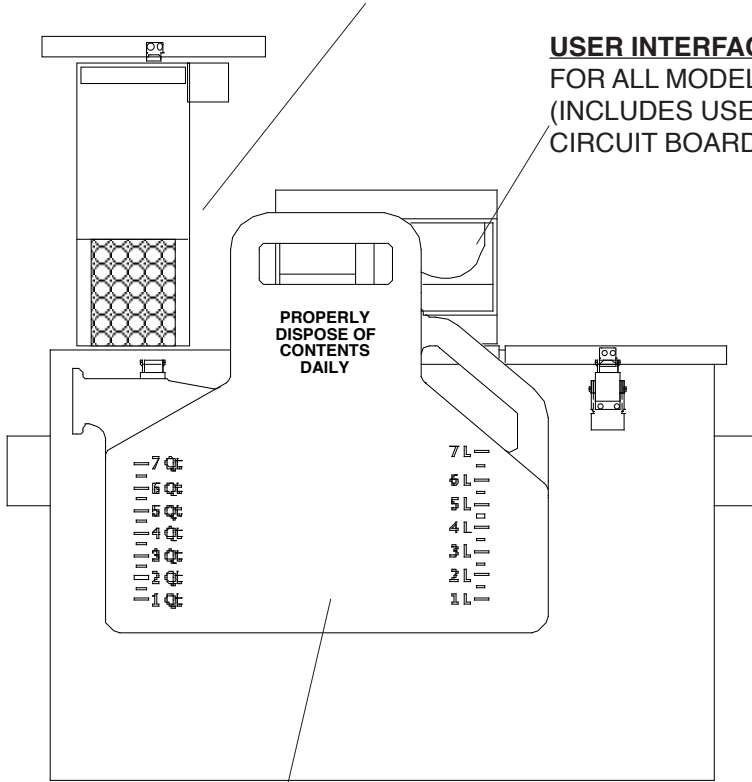

USER INTERFACE (Under Cover)

FOR ALL MODELS USE PART# PCBA-2
(INCLUDES USER INTERFACE, RIBBON CABLE, PRINTED
CIRCUIT BOARD AND THERMISTOR)

NOT SHOWN:

MOTOR (1 per unit)

PART# M-58
M-58-230 in 230 VAC Units

HEATER (1 per unit)

PART# H-8
H-8-230 in 230 VAC Units

INTERNAL FLOW CONTROL (1 per unit)

PART# MFC-20 FOR W-200-IS
PART# MFC-25 FOR W-250-IS
PART# MFC-35 FOR W-350-IS
PART# MFC-50 FOR W-500-IS

LID GASKET

PART# RG-7

WHEEL WIPER ASSEMBLY (1 per unit)

PART# WWA-4

WHEEL DRIVE SPROCKET (1 per unit)

PART# WDS-3

SKIMMING WHEEL ASSEMBLY (1 per unit)

PART# PDA-3

SAFETY SWITCH

PART# MSS-7

HEATER GASKET

PART# HTG-300

GREASE/OILS COLLECTION CONTAINER

FOR W-200-IS THROUGH W-500-IS USE PART# GC-7



40000 Series

Big Dipper® Limited Warranty & Remedy

Thermaco, Inc. warrants to the original user that the products manufactured by it delivered with this warranty shall be free from material defects in workmanship and materials for a period of 12 months from the date of invoice to the distributor (if sold by an authorized Thermaco distributor) or the date of invoice to the purchaser (if sold directly by Thermaco, Inc.), but in no event longer than 15 months from date of shipment from Thermaco's production facility.

Any claim must be made in writing to Thermaco at 646 Greensboro Street, Asheboro, NC 27203 promptly after discovery of the defect and within the applicable warranty period. The product must be delivered, prepaid, to Thermaco, together with proof of purchase, the serial number from which the item was removed and a return authorization number issued by Thermaco. If Thermaco determines upon examination that the component is defective and that the warranty conditions are met, Thermaco's sole obligation under this warranty, and the purchaser's sole and exclusive remedy, is the repair or replacement, at Thermaco's option, of the defective component, including parts and labor. The replacement will be furnished F.O.B. point of shipment. If Thermaco determines that the component is not defective or that the other conditions of this warranty are not met, then any return of such part to the purchaser shall be at purchaser's cost.

This warranty shall not cover any defect in otherwise covered products resulting directly or indirectly from: (i) failure to properly install, operate or maintain the product in accordance with Thermaco's instructions and procedures, including, without limitation, use in excess of rated flow, operation without digital control, improper electrical service, use to remove emulsified fats and oils or use that fails to comply with applicable laws, regulations or codes; (ii) damage in transit, handling or installation; (iii) modifications, adjustments, repairs, or alterations made by unauthorized persons; or (iv) other causes not arising out of defects in workmanship or materials. Thermaco shall not be responsible for damage to products resulting from vault flooding, sewer line back-up, pumping or lift station failure, ambient water flow or other sources of water damage. This warranty does not cover equipment or parts not manufactured by Thermaco. Purchaser's costs relating to any service, adjustment, removal, repair, packing, or otherwise incurred with respect to the defect prior to submission for warranty are the responsibility of purchaser.

No distributor, sales person or other person is authorized to make any warranty statements on behalf of Thermaco regarding Thermaco products other than as set forth in this warranty. This statement of warranty supersedes any quote, brochure, or other statement or document with respect to warranty of Thermaco products.

EXCEPT AS EXPRESSLY SET FORTH ABOVE, THERMACO, INC. MAKES NO REPRESENTATIONS, WARRANTIES OR GUARANTEES, EITHER EXPRESSED OR IMPLIED, INCLUDING, WITHOUT LIMITATION, AS TO **MERCHANTABILITY OR FITNESS FOR A PARTICULAR PURPOSE**, WHETHER OR NOT THERMACO HAD KNOWLEDGE OF PURCHASER'S PARTICULAR REQUIREMENTS OR NEEDS, OR WITH RESPECT TO ODOR GENERATION OR OTHER INCIDENTALS RELATING TO USE OF THE PRODUCT.

The sole and exclusive remedy with respect to this warranty any other claim relating to defects or any other condition or use of Thermaco products, however caused, and whether such claim is based upon warranty, contract, tort, strict liability or any other theory, is LIMITED to the repair or replacement of the product, excluding labor or any other cost to remove or install said the product or, at Thermaco's option, repayment of the purchase price. IN NO EVENT SHALL THERMACO, INC. BE LIABLE, WHETHER IN CONTRACT, WARRANTY, TORT (INCLUDING NEGLIGENCE), STRICT LIABILITY, INDEMNITY OR ANY OTHER LEGAL THEORY, FOR INCIDENTAL OR CONSEQUENTIAL DAMAGES, OR FOR ANY OTHER LOSS OR COST OF A SIMILAR TYPE. UNDER NO CIRCUMSTANCES WILL THE AGGREGATE LIABILITY OF THERMACO FOR ANY CAUSE OF ACTION RELATED TO THE PRODUCTS COVERED HEREBY EXCEED THE NET PURCHASE PRICE RECEIVED BY THERMACO FOR THE PRODUCTS. Any action or suit by purchaser against Thermaco relating to Thermaco products must be brought within one (1) year of the date of the invoices referenced above. The exclusions and limitations set forth herein are separate and independent from any remedies which purchaser may have hereunder and shall be given full force and effect whether or not any or all such remedies shall be deemed to have failed of their essential purpose.