



Domino VGS

Vertical Gravity Separator





Domino VGS

Introduction

Product Overview

The **Domino VGS** is an oil/water separator developed to effectively remove free oil, grease and suspended solids from wastewater.

The Domino VGS operates by ingenious control of both fluid velocity and pressure. These forces gently coax non-emulsified impurities from water by allowing high density contaminants to fall into a sludge retaining area at the bottom of the vessel, and oil droplets and low density suspended solids to rise to the top of the vessel. The oil and suspended solids then drain of into a waste tank.

Acclaimed by major water authorities around the world as "the best technology of its kind", the Domino VGS can be used as a stand-alone separator or to supplement the performance of existing systems.

Because it stays clean it maintains its performance!

Features & Benefits

Performance

Due to its ingenious design the Domino VGS is capable of continually meeting the performance standards set by the EPA and other regulatory authorities.

Suspended Solids

Low density suspended solids are encapsulated by the oil and progress to the top of the Domino VGS for discharge to the waste tank. Heavy solids settle to the base of the unit and are removed from the system by the way of a control valve.

Flammability

The turbulent flow principle of the **Domino VGS** ensures the vapour content of the wastewater being treated is always reduced to safe levels.

Maintenance

Unique design features enable quick, on-line cleaning of the unit; a feature only found on the **Domino VGS**. The need to remove plates and use high pressure jets or chemicals to clean conventional separators has been eradicated.



Construction

By utilizing a vertical cylinder design the **Domino VGS** requires far less floor space compared to other systems.



Domino VGS

The Technology

Principle of Operation

The **Domino VGS** is a flooded system in which the inlet and outlet columns form a U - tube configuration. The free oil and low - density suspended solids are trapped on one side of the main body and the treated water flows out the other side.

The main body of the unit contains an oleophilic polyethylene cone set. Stainless steel cone sets are available if required.

At the top of the main body free oil and low density suspended solids are held and eventually they flow out of the system into a waste tank.

The partially cleaned water is directed to the outside of the cones. It then follows a tortuous pattern cascading down and around the cone set.

Here the lower density fluid (oil) is drawn up the incline of the oleophilic surface of the cone set and back into the low-pressure centre of the Domino VGS, where it co-mingles with the incoming fluid and is redirected to the top of the main body.

Convection current is thus created by the density variation down the fluid column and the upward flow of the incoming oily water.

The “treated”water will enter the output leg, at a point when the fluid is most free of contaminants, and flow up and out of the system.

Heavy solids and sludge are removed from the system via a sludge valve at the base of the main body

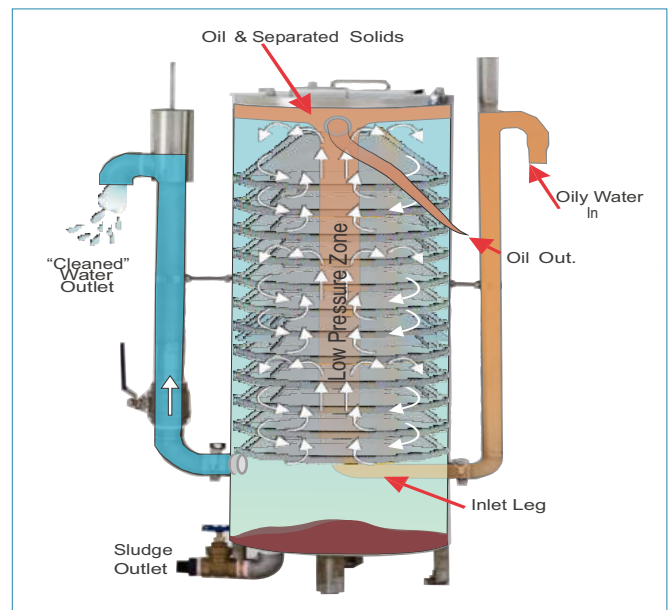

How a Domino VGS Works

Domino VGS

Typical Manual Domino Separator Installation

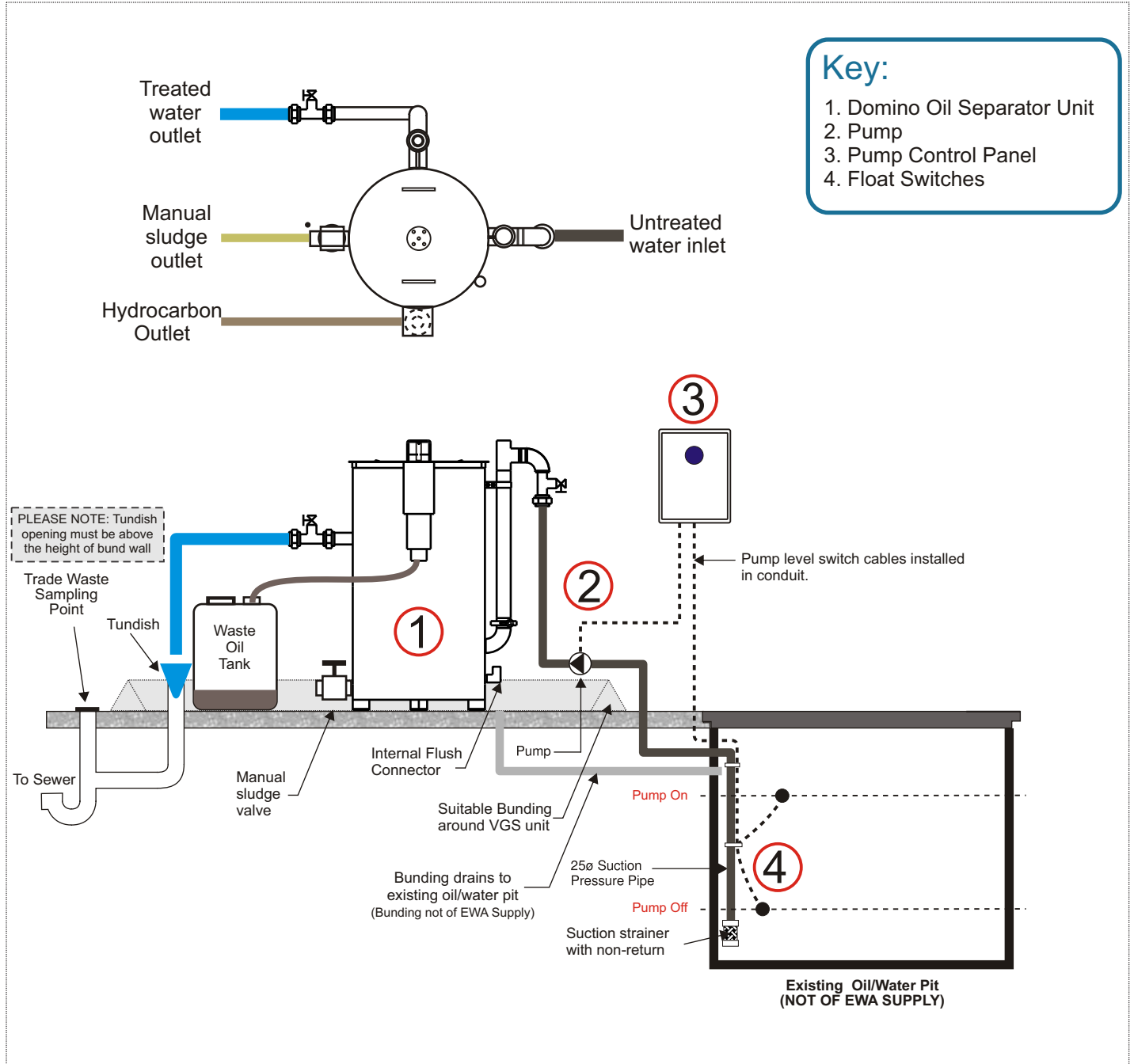



Domino VGS

Domino DV700 Technical Specifications

Height:	918mm
Diameter:	355mm
Weight:	60kg
Gauge:	2.0mm

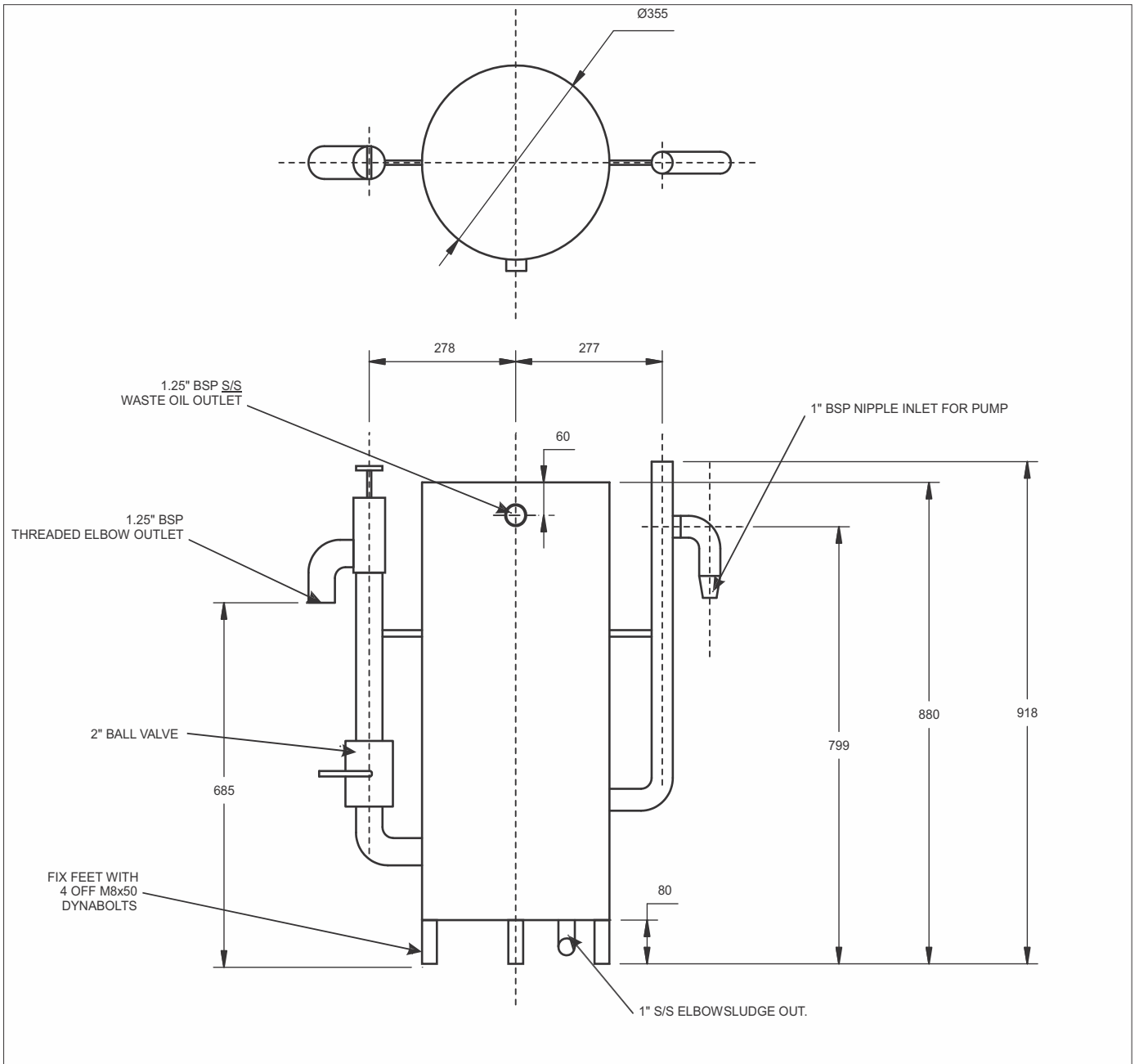



Domino VGS

Domino DV1500 Technical Specifications

Height:	1377mm
Diameter:	452mm
Weight:	76.5kg
Gauge:	2.0mm

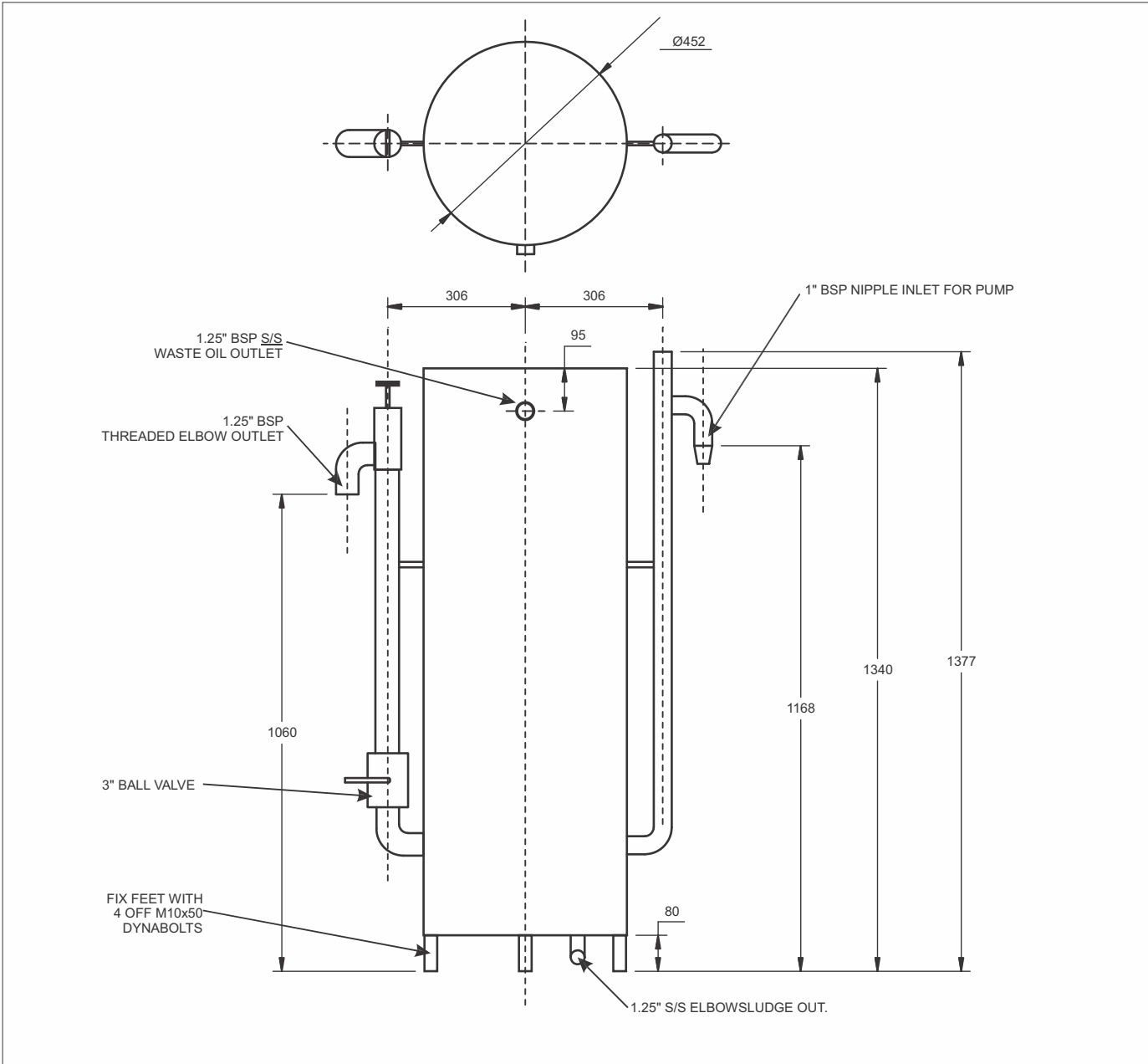



Domino VGS-NG*

WASH PAD CHECK LIST PRIOR TO EQUIPMENT INSTALLATION

✓	DESCRIPTION
	COLLECTION PIT (2 TANK SYSTEM PREFERABLE)
	PERIMETER WASH PAD BUNDING
	BUNDED EQUIPMENT PAD WITH A FLOOR DRAIN TO THE PIT (IF SEPARATE TO WASH PAD)
	INDUSTRIAL WASTE SAMPLING POINT (IWSP)
	REDUCED PRESSURE ZONE (RPZ) FITTED TO WATER SUPPLY HOSE COCK

