

INSTALLATION, OPERATION AND MAINTENANCE MANUAL

Ultraspin Oily Water Separators Pneumatic

Models: PC35-MAN
PC35-AR
PB35-MAN
PB35-AR
PB70-AR



Document Title	Ultraspin Standard IOM Manual – Oily Water Separators: Pneumatic
Document Number	MAN001
Revision Number	0
Revision Date	16/05/2018
Supplier Name	Ultraspin Technology Pty. Ltd.

Table of Contents

1	Principles of Operation	5
1.1	Separator.....	5
1.2	Typical Process Description.....	6
1.3	Description of Key Items	8
1.4	Data Summary.....	10
2	Installation Instructions	11
2.1	Services Required Prior to Installation.....	11
2.2	Ultraspin Separator Installation.....	12
2.3	Installation Checklist	13
2.4	Commissioning.....	14
3	Operating Instructions	15
3.1	Routine Operation Checks	15
3.2	Debris Strainer Cleaning Procedure.....	15
3.3	Operator Emergency Situations.....	15
4	Maintenance Instructions	16
4.1	Minor Service	17
4.2	Major Service	19
4.3	Specialist Servicing.....	22
4.4	As Required Service and Maintenance	23
5	Troubleshooting Matrix	26
6	Drawings Schedule.....	28
7	Appendices.....	29
7.1	Appendix 1 – Operation Checklist.....	30
7.2	Appendix 2 – Separator Liner Reject Orifice Wear	31
7.3	Appendix 3 - Sampling Procedure.....	34
7.4	Appendix 4 - Factors Affecting Oil Water Separation Performance	35
7.5	Appendix 5 - Spare Parts List	36
7.6	Appendix 6 - Equipment Data Sheets	37
7.7	Appendix 7 - Process and Mechanical Drawings	38

Important Notes to Read Before Commencing Any Work

Safety	<p>Before attempting to undertake installation, maintenance or repair work of any nature, the persons concerned should be alerted to the nature of the risks involved when working in a situation of a potentially hazardous nature. As it is not possible to cover every aspect of safety in a single article, care has been taken in preparation of the following notes, which should serve as a general guide to the most common situations likely to be encountered.</p> <p>It is necessary to point out that Ultraspin or any of its associates cannot accept responsibility for any form of personal injury, however caused. Therefore, every care should be taken to observe the normal rules of safety.</p>
Approvals	<p>The manual is intended as a guide only. If required, site-specific drawings, Council, Water, Electricity Authority and Government approval and professional advice shall be obtained prior to installing the equipment mentioned in this manual.</p>
Warning	<p>Certain instructions and advice carry this tag. This information should NOT be ignored or damage to equipment or personnel could result.</p>
Warranty	<p>The data is based on tests and experience which Ultraspin Technology Pty Ltd believe reliable and is supplied for information services only. Ultraspin Technology Pty Ltd disclaims any liability for damage or injury which results from the use of the enclosed data and nothing contained therein shall constitute a guarantee, warranty or representation (including free from patent liability) by Ultraspin Technology Pty Ltd with respect to the data, the product described, or its suitability for any specific purpose, even if that purpose is known to Ultraspin Technology Pty Ltd.</p>
Patents	<p>Ultraspin Technology Pty Ltd has patented features of the skimmer, hydrocyclone and processes covered in this literature. Processes or products in this manual should not be used without the prior written consent of Ultraspin Technology Pty Ltd.</p>
Update	<p>Data subject to correction and update without notice</p>
Copyright	<p>Ultraspin Technology Pty Ltd © 2010-2018; All rights reserved</p>
Standards	<p>This Ultraspin Separators are designed to comply with some or all of the following standards: NSW Land & Water Conservation, January 1997 Guidelines for the On-Site Treatment of Trade Waste Discharge to Sewer AS/NZS 4494:1998 Discharge of Commercial & Industrial Liquid Waste to Sewer – General Performance Requirements National Water Quality Management Guideline for Sewerage Systems, November 1998 A list of manufacturing standards is available on request.</p>
Design	<p>This manual is not a design guide. It does not provide a substitute for careful planning and a considered site design drawing prepared by qualified and experienced people. If there is any uncertainty with design the service of competent design engineers experienced in oily water and local requirements should be sought. If needed Ultraspin can provide a list of recommended designers.</p>

Ultraspin Technology Contact Details

Company Name:	Ultraspin Technology Pty Ltd
ABN:	53 101 873 250
Address:	46 Wadhurst Drive, Boronia VIC 3155
Telephone:	+61 3 8841 7200
Email:	sales@ultraspin.com.au
LinkedIn:	www.linkedin.com/company/ultraspin-technology-pty-ltd
YouTube:	www.youtube.com/user/UltraspinTechnology

1 Principles of Operation

1.1 Separator

The Ultraspin separator treats water contaminated with oils, fats, grease, hydrocarbons and suspended solids. This separation is based on the contaminants particle size and their density difference with water.

The heart of the Ultraspin system is the Ultraspin separator itself.

The Ultraspin separator is a long, tapered cone shaped device with one inlet and two outlets. The treated water exits the separator from the outlet at the narrow end of the separator, while the separated oil droplets exit from the larger end of the separator.

Oily water is pumped into the Ultraspin separator through tangential inlets in the head of the separator. This starts a spinning flow that causes a powerful vortex to form within the separator. This vortex accelerates the flow as it moves further through the tapered section of the separator.

This spinning vortex creates a centripetal force that acts on the lighter oil droplets and causes them to move to the center of the vortex. Once in the center of the vortex, running the length of the separator, correct separator pressure settings cause the oil droplets to flow out of a small hole in the end face of the inlet end of the separator for storage.

This leaves the now treated water to flow out of the narrow end section of the separator to be discharged.

Why Is It Such a Powerful Separator?

Unlike other separators the Ultraspin separator does not rely on weak gravity forces for separation. The centripetal force generated inside the vortex of the Ultraspin separator is approximately 1,000 times the force of gravity. With such force even small emulsified oil droplets can be separated, even if under 10 microns in diameter.

The Ultraspin separator is one of the simplest and most powerful oily water separators available, and with no consumables or no chemicals.

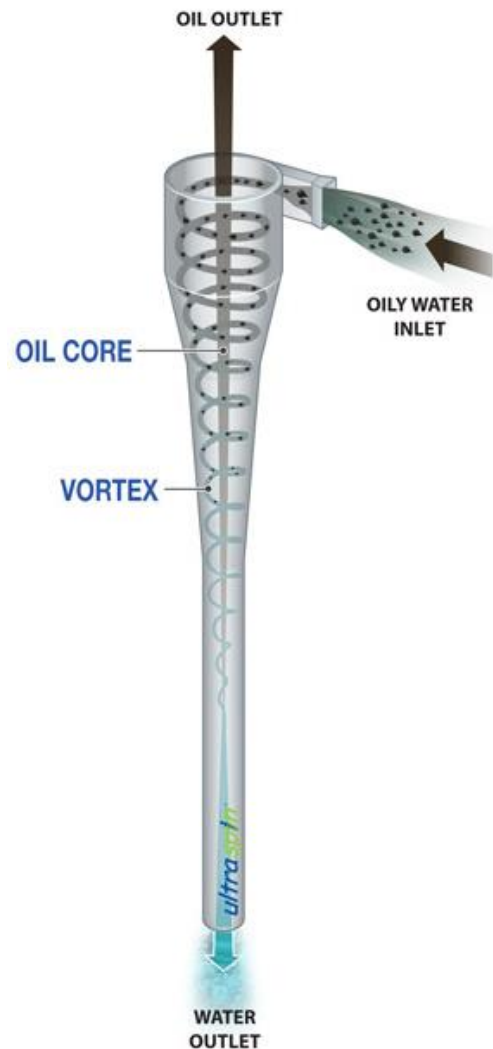

1.2 Typical Process Description

The Ultraspin separator can be used in a variety of ways on many different customer applications. The following description is generalised and is provided to illustrate a typical configuration.

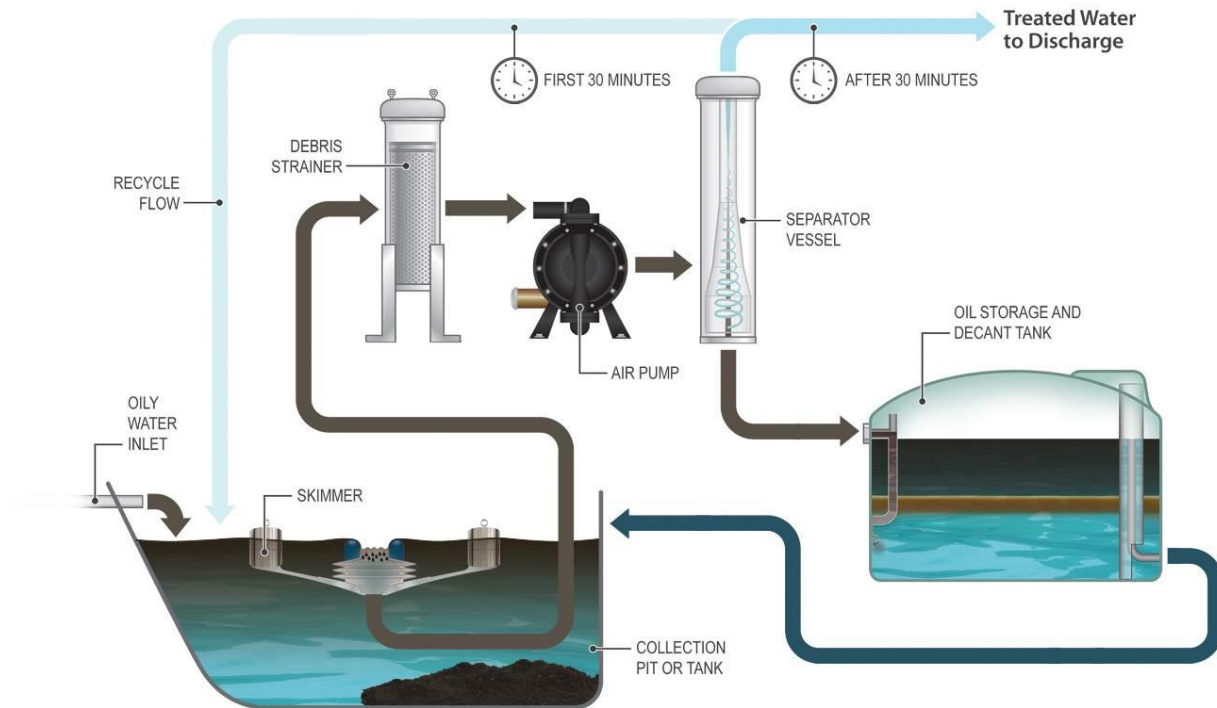

Overview

The Ultraspin Oily Water Separator typically draws waste water contaminated with oils, fats, grease, hydrocarbons and suspended solids from a site pit or a tank. It then separates the contaminated water into a treated water stream and separated oily reject stream. The treated water is recycled (if the system is fitted with this option) to the feed pit to be retreated or sent to the site discharge point. The separated oily stream is sent to an oil storage and decant tank where separated oil is collected, and excess water is automatically drained off back to the pit.

The contaminated oily waste water is collected in a pit/tank where the separator draws the water through an Ultraspin Oil Skimmer. This removes built up oil layers from the pit and means the Ultraspin system can treat the worst waste water first. This prevents the build-up of unsightly and potentially hazardous oil layers. By skimming from the surface and eliminating oil layer build-up also mean that if the pit were to flood, relatively clean water would be spilt, not oil!

The skimmed water passes through a large debris strainer which removes debris over 3mm. This helps prevent blockages and increases the life of downstream equipment.

The Ultraspin separator utilises an air operated diaphragm pump to pump the oily water through the system. The pump selected is a low-shear model, this pump is chosen to minimise emulsification, which would make separation more difficult. Other advantages of the air operated diaphragm pump are that it is self-priming and can tolerate up to 8mm solid particles.

The pump discharge flows to the Ultraspin separator, which is a long, tapered cone shaped device that creates high centripetal forces to separate oil droplets from the water. The major advantage over other oily water treatment systems is that there are no moving parts in the Ultraspin separator and therefore no items to clean or intensive maintenance regimes.

The separated oily reject stream from the Ultraspin separator flows to the Oil Storage and Decant (OSD) tank. The separated oil contains some water, this is common with all types of oil separators. The OSD tank design allows excess water to automatically drain out of the tank while a thick oil layer builds up over time. The water that drains out of the tank is returned to the beginning of the process for retreatment. As the tank fills up with oil, the level will slowly rise. A level indicating dipstick can be used to gauge the oil level height so that disposal may be arranged when full.

Optional pneumatic controls provide the operating logic for the operation of the Ultraspin separator. A fully pneumatic level switch connected to the Ultraspin separator triggers the system to start and stop at high and low pit/tank water levels respectively. Additional recycle control is provided by a pneumatically actuated valve, which initially diverts the treated water from the separator back to the feed pit/tank for retreatment. After a set period of time the valve will actuate and the treated water will be diverted from recycling back to the pit to the discharge point.

1.3 Description of Key Items

This manual covers a variety of Ultraspin separator models and not all parts of this manual may be relevant. Please ensure you check your exact equipment as to what sections of this manual are applicable.

1.3.1 Oil Skimmer (option)

For information regarding the installation, operation and maintenance of the Ultraspin skimmer please refer to the skimmer manual.

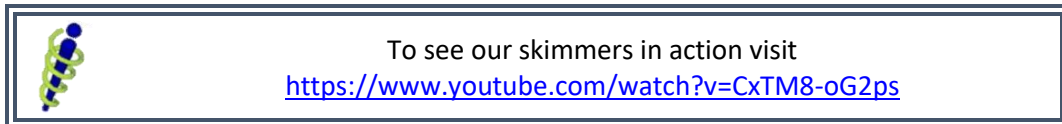

1.3.2 Level Switch (option)

These models of Ultraspin system use fully pneumatic, float type level switches, the level switch consists of two floats. The level switch will activate the OWS when the water level rises above both low-level and high-level floats. The OWS will continue to operate until the water level drops below the low-level float.

1.3.3 Backup Strainer

All Ultraspin separators use large strainers to prevent debris from blocking or causing premature wear to critical system components such as pumps and valves. The inlet strainer basket should be monitored and cleaned as per instructions in this manual.

Note: The back-up strainer is not a substitute for debris screening in the site civil design. Proper site design with trash screens in pits and tanks will prevent the back-up strainer from filling too quickly.

1.3.4 Air Operated Diaphragm Pump

A low shear air operated diaphragm pump provides the feed water pressure to drive the fluid through the Ultraspin separator. This pump has been selected to minimise emulsification of the oil droplets within the oily water. It is also self-priming and tolerant of small solids.

It is the customers responsibility to carry out proper site design to ensure there is sufficient NPSHA for the pump to operate successfully.

1.3.5 Ultraspin Oil Separator

The contaminated oily water is pumped tangentially into the large diameter end of the Ultraspin separator liner. This initiates a spinning vortex which creates the driving force for separation. This spinning vortex is accelerated as it moves down the tapered separation liner generating centripetal force equal to 1000 times the force of gravity. This centripetal force causes the tiny oil droplets to move to the center of the vortex.

This creates two separated streams:

- Treated Water Stream - which is discharged or recycled back to the pit (if recycle option is fitted)
- Oil Reject Stream - which is sent to an oil storage and decant tank.

1.3.6 Pneumatic Control Circuit

The control circuit provides the control logic for the system to operate.

1.3.7 Recycle/Discharge Function (option)

The Ultraspin OWS recycle function allows the treated water to be returned to the collection pit, on start-up, for a pre-programmed period.

This feature may be beneficial when:

- There is a possibility of very high oil load in the collection pit.
- Very high discharge water quality is required
- Dissolved hydrocarbons may be present

The recycle period will initially be set by Ultraspin in our factory prior to delivery. The recycle period may be adjusted during commissioning by an Ultraspin engineer, depending on the specific site conditions. It can also be adjusted in accordance with site conditions by suitably qualified personnel.

During recycle there will be no discharge of treated water from the system. The OWS continues to work and the separated 'reject' stream will flow to the OSD. Once the pre-set recycle time has expired, the 3-way ball valve will actuate to allow treated water to be discharged from the system.

The system will continue to treat the water and discharge until the system is switched OFF either manually or by the control circuit and level switch.

Each time the system restarts, the recycle timer will reset and treated water will be recycled until the recycle time has expired again. The ¼-turn 3-way ball valve is actuated using compressed air controlled by a pneumatic/mechanical timer.

Important Note:

In 'recycle mode' the system will treat the water but it is returned to the feed collection pit. There will be no discharge of water until the recycle time has expired.

1.3.8 Manual Operation (option)

Some models of OWS come as a 'Manual Only' operation. This means that the OWS must be manually operated by the compressed air supplied to the system controls and the pump. There are no level switches controlling the system.

1.3.9 Oil Storage and Decant Tank (option)

The separated oil and sludge can be stored in an oil storage & decant (OSD) tank. This tank is either integrated with the system or a separate tank depending on the model. The stream that is connected to the OSD contains the separated contaminants (oil, grease, hydrocarbons, suspended solids) and some water. The long settling time in the tank allows the oil rich sludge to float up and collect at the top of the OSD tank. Excess water on the bottom of the tank is automatically drained from the OSD tank. This water is not clean and is typically returned to the contaminated water pit or tank for treatment. The separated contaminants (oil, grease, hydrocarbons, suspended solids) build up over time and the tank must be periodically emptied.

- See Maintenance Section of this IOM manual for OSD emptying instructions

1.3.10 Aeration Tanks and Blowers (option)

For information regarding the installation, operation and maintenance of the Ultraspin aeration tanks and blowers please refer to the separate Aeration Tanks and Blowers manual.

1.4 Data Summary

See Appendix 7.6 for data sheets for individual equipment.

2 Installation Instructions

Important Note:

- This section does not provide recommendations for site design, including pipe runs, pipe sizes and other important site matters. It is the responsibility of the user to ensure there is proper site design by others BEFORE installation.
- The following is typical and general information only. Sites and client requirements may vary from what is described here.
- Unless we have specifically indicated otherwise in writing, any drawings provided that show site configuration or arrangements are TYPICAL ONLY and do not constitute site design recommendations.

2.1 Services Required Prior to Installation

Please ensure that the following services are available and fully functional before attempting to install the OWS:

- Oily water collection pit/tank, bunding and related infrastructure.
- Drainage from all areas to the main oily water collection pit / tank / pond.
- Compressed air to supply air to the separator skid pneumatic take-off point.
- Fresh water hose, hose reel (or similar) is available to facilitate cleaning and maintenance.

Important Note:

- The installer is to supply all interconnecting hoses and fittings (scope defined in drawing).
- Ultraspin can provide hoses and fittings once required lengths are specified (if requested).

Important Note:

An orifice is located prior to the valve termination point on the Ultraspin skid on the treated water outlet manifold. This must always remain installed (between the BSM fittings) to maintain the correct backpressure for correct operation of the Ultraspin Separator.

Important Note:

There are to be no pressure restrictions installed on the downstream side of the treated water stream (such as filters, water meters. etc.), as these will adversely affect the performance of the separator.

2.2 Ultraspın Separator Installation

2.2.1 Safe Maintenance Access

The Ultraspın system should be located so that there is approximately 1000 mm clearance around the equipment to enable maintenance access. It is particularly important to leave clear access to the strainer basket, the pump and the vessel for maintenance.

2.2.2 Process Connections

All process connections to Ultraspın equipment must be at least the size specified in the Piping and Instrumentation Diagram and Datasheet. (see Appendix 7.7)

The PSV valve can be connected to site drains if required, but do not install any valves or restrictions in this line.

2.2.3 Level Switch (optional)

Before installing the level switch you will need to determine the minimum operating water level in the feed pit/tank. The level switch should be mounted so that the low-level float hangs down to this level.

Three 6 mm O.D. nylon airline tubes are required to connect the level switch to the Ultraspın separator skid. On the side of the level switch there are three pushfit connections labelled 'S', 'P' & 'T' these need to be connected to the corresponding pushfit connections on the filter regulator, also labelled 'S', 'P' & 'T'.

2.3 Installation Checklist

The following installation checklist confirms all the major requirements to complete the installation of the Oil Separation system.

Item	Equipment Name	Installation Requirements
1	Oily Water Separator	<ul style="list-style-type: none"> • Move into position • Bolt to the ground • Process connection from oil skimmer hose • Process connection to site treated water discharge point • Recycle process connection to oily water pit (if fitted) • Process connection to Oil Storage and Water Decant Tank (if fitted) • Connect air lines from level switch (if fitted)
2	Oil Skimmer	<ul style="list-style-type: none"> • Install suction hose • Lift skimmer and hose into oily water collection pond • Check that skimmer is free floating
3	Oil Storage and Decant Tank	<ul style="list-style-type: none"> • Process connection from Oily Water Separator to Oil Storage and Decant Tank • Process connection for Decant return into oily water pit
4	Level Switch	<ul style="list-style-type: none"> • Bolt to side of oily water pit containing skimmer • Attach airlines from the level switch to the oily water separator

2.4 Commissioning

All commissioning work should be carried out in accordance with Company, Government or National Standards and the requirements of any other relevant authority and permits must be obtained where required. Prior to commissioning this equipment, please ensure that all aspects of installation have been dealt with.

Important Note:

Commissioning procedures vary widely with due to specific Company, Site, and Departmental Requirements, or State and/or Federal Governmental or National Standards.

Ultraspin is therefore not possible to provide site specific commissioning details in this manual.

Ultraspin qualified and trained Field Engineers can provide full comprehensive on-site commissioning services, please contact Ultraspin for details.

3 Operating Instructions

3.1 Routine Operation Checks

When installed correctly, Ultraspin Separators are extremely reliable and requires little operator attention. Typically, no daily operator checks are required. However, periodic operational checks by filling in the Operational Checklist (located in Appendix 7.1) should ensure that the Ultraspin system is working correctly.

These checks are very simple and can be performed by any operational personnel.

3.2 Debris Strainer Cleaning Procedure

- Switch off the OWS by closing the manual air supply ball valve prior to the pneumatic filter-regulator.
- Bleed down pressure by opening the separator sample points.
- Unscrew the eye bolts on top of the debris strainer.
- Remove the lid. You may need to apply slight force to overcome any residual vacuum.
- Carefully remove the perforated sheet strainer basket from the strainer vessel
- Dispose of the debris from the strainer in an appropriate location. DO NOT allow removed debris to be returned to the collection pit.
- Re-install the strainer basket
- Completely fill the strainer with clean water
- Place the lid back on top of the strainer and tighten the eye bolts.
- Separator can now be restarted

Important Note:

NEVER open the strainer with the separated pump operating or with the system in any mode where auto start-up could occur. Isolate the air supply at the feed to the filter-regulator prior to clearing the strainer.

3.3 Operator Emergency Situations

3.3.1 Stopping the Ultraspin Separator Pump

The system operation can be stopped at any time for any reason by closing the air inlet valve to the individual filter-regulator on the separator pump.

3.3.2 Oil Spills

If there is a large oil spill into the oily water collection pit, or the feed of the Ultraspin System then the system must be stopped immediately.

Individual company policy and procedures will define what a 'large oil spill' is. After a large oil spill company policy will direct operators in correct disposal procedures. Ensure that the oil spill has been correctly dealt with before resuming operation of the Ultraspin separator.

4 Maintenance Instructions

When installed correctly, the Ultraspın Separator is extremely reliable and requires little maintenance. When maintenance is carried out in accordance with the following schedule this should ensure:

- Treated water discharges that comply with regulations and other requirements.
- Reliable, long term mechanical operation

Important Note:

The frequency of the following schedule is based on typical applications and may vary depending on your site conditions and the nature of your oily water.

Recommended Maintenance Schedule

Maintenance Level	Recommended Min. Frequency	Required Qualifications
Operational Checks	Weekly	Any operational personnel
Minor Service	6-monthly	Any trade qualified site technician – or similar
Major Service	3-yearly	Trade qualified technician with oily water training*
As Required Service	As required – dictated by outcomes of operational checks	Any trade qualified site personnel – or similar
Specialist Servicing	As required – breakdowns	Ultraspın Field Service Engineer

* Major Servicing requires a higher degree of specialised oily water and oily water separator technology knowledge. Ultraspın Technology provides free of charge in-house training on oily water separator Major Servicing for any suitably qualified personnel.

4.1 Minor Service

For some oily water applications, Minor Service intervals may need to be altered. Please also note that some regulating authorities may require maintenance to be carried out at defined intervals (consult local authorities for details). The maintenance requirements detailed in AS/NZS 4494: 1998 must also be considered.

Approved and competent trade qualified site personnel can carry out Minor Servicing.

4.1.1 Minor Service Overview

Min. frequency:	6-Monthly
Tools required:	24mm spanner x 2 Flat blade screwdriver Soft faced hammer
Parts required:	Minor Service Spare Parts items as detailed in Appendix 7.5 Silicon grease Cleaning rags
Typical time to complete:	One person, 2 hours

4.1.2 Initial Visual Inspection

- Manually start the OWS. Inspect the OWS and surrounds for leaking pipes, hoses, fittings, and valves or pump seals.
- Inspect the oil skimmer in operation: It should be drawing surface fluid in a consistent and evenly distributed flow across its donut shaped weir.

4.1.3 Clean Strainer

- Clean the Debris Strainer as per the instruction in the Operating Instruction, Section 3.2 of this manual.

4.1.4 Assess Liner Head Wear

- Using Ultraspin Liner Inspection Kit and instructions found in Appendix 7.2.
- Please contact Ultraspin Technology for a Liner Inspection Kit

4.1.5 Oil Separation Liner o-ring Replacement

- Inspect the reject and inlet holes for blockages and clear if required. Make sure any debris is flushed completely clear of the liner.
- Remove the o-rings on the inlet head and treated water end of the OWS separation liner.
- Install new o-rings as in the Minor Service Kit. Use grease and take care not to damage o-rings during installation.
- Reinstall the separation liner into the separator vessel and gently tap with a soft faced hammer until the liner seats into the vessel end plate.
- Replace the end flange and tighten the hex head bolts
- Close sample valves.

4.1.6 Operation of System after the Service

After a minor service check that the OWS system operates as expected by performing the Routine Operation Checks (Appendix 7.1).

4.2 Major Service

Approved client staff can carry out Minor Servicing. However, Major Servicing requires a higher degree of specialised oily water and oily water separator technology knowledge.

Ultraspin Technology provides free of charge in-house training on oily water separator Major Servicing for any suitably qualified personnel.

Ultraspin Technologies Field Service Engineers provides full servicing capabilities ensuring that your Oily Water separator is working at full capacity and that you are not at risk of non-compliant discharge.

Min. frequency: 3-Yearly (or less subject to site requirements)

Tools required: 24mm spanner x 2
Flat bladed screwdriver
1" & 1-1/2" BSM spanners
Soft faced hammer

Parts required: Major Service Spare Parts items as detailed in the Appendix 7.5
Silicon grease
Cleaning rags

Typical time to complete: One person, 3 hours

4.2.1 Separator liner replacement

- Isolate the OWS by closing the air supply at the filter-regulator
- Bleed down pressure via the separator sample points. Leave the sample ports open.
- Undo the hex bolts on the flange on the end of the separation vessel and remove the flange.
- Remove the separator liner from the vessel using a long screwdriver inserted into the removal holes
- Pull the old separator liner out of the vessel slowly
- Grease the O-rings of the new liner with silicon grease
- Install the new separator liner into the separator vessel and gently tap with a soft faced hammer until the liner seats into the vessel end plate
- Replace the end flange and secure the hex bolts.
- Close sample valves.

4.2.2 Filter-regulator assembly replacement

- Shut down the pump by turning off the air supply to the filter-regulator
- Disconnect the air supply completely
- Disconnect the 4 x 6mm & 1 x 12mm air lines from the filter-regulator assembly
 - 1 x 6mm air line between the filter-regulator assembly and the timer box
 - 3 x 6mm air lines (labelled S, P & T) that connect the filter-regulator assembly to the level switch
 - 1 x 12mm air line between filter-regulator and the pump
- Remove the filter-regulator assembly from the process connection panel
- Attach the new filter-regulator assembly from the Major Service kit.
- Reconnect the air supply to the new filter-regulator and check for any air leaks
- Adjust air pressure on the filter regulator to ensure a steady pressure of 550 kPa
- Test all functions of the Ultraspin unit are working correctly

4.2.3 Strainer vessel seal replacements

- Shut down the pump by turning off the air supply to the filter-regulator
- Bleed down pressure via the separator sample points. Leave the sample points open.
- Undo the 6 x eye bolts on the lid of the strainer vessel
- Remove the strainer lid
- Replace the top o-ring in the grove seal between the strainer vessel and the strainer lid with the o-ring in the minor service kit
- Undo the 1-1/2" BSM union on the bottom of the strainer vessel
- Lift strainer and replace with o-ring in the minor service kit
- Close sample valves.

4.2.4 Treated water orifice & BSM seal replacement

- Shut down the pump by turning off the air supply to the filter-regulator
- Bleed down pressure via the separator sample points. Leave the sample points open.
- Undo the 1-1/2" BSM union outlet on the treated water outlet
- Replace the treated water orifice and the o-ring
- Reinstall and retighten the BSM union
- Close sample valves.

4.2.5 S1 Skimmer internals kit replacement

- Shut down the pump by turning off the air supply to the filter-regulator
- Remove S1 skimmer from pit and disconnect from skimmer hose by undoing camlock quick connection
- Undo the stainless-steel worm-drive clamp that connects the canvas bellows to the stainless-steel skimmer body
- Install the new skimmer internals kit from the Major Service kit, by slipping the bellows and worm-drive clamp over the skimmer body.
- Align the bellows with bead on the skimmer body by using the pull tabs
- Tighten the worm-drive clamp and reinstall the skimmer onto the skimmer hose camlock connection

4.2.6 Performance confirmation

- Once the Major Service has been completed they performance of the system must be confirmed
- Complete the Routine Operation Checks (Appendix 7.1).
- Measure the flowrates of the reject and treated water streams and confirm the correct reject ratio is attained.
- Take accurate visual samples of the Inlet, Outlet and Reject, as per the sampling procedure in Appendix 7.3.
- Confirm that the separator is working as required following the Major Service

4.3 Specialist Servicing

The servicing described above should ensure reliable operation of the Ultraspin system. In many situations, OWS owners will prefer Service and Maintenance to be carried out by OWS specialists who can carry out more specialised work. Ultraspin offers this higher level of service compared to that available via general maintenance staff.

Ultraspin qualified service engineers are familiar with all aspects of this OWS design. Ultraspin can assist with your operational and preventative maintenance schedules:

- Comprehensive Ultraspin service
- Evaluate process design.
- Evaluate site civil infrastructure.
- Audit site oily water sources. Classify all sources of oily water in terms of treatability.
- Review original equipment purchased compared to current use/requirements.
- Fitting spare parts and system recommissioning.
- Advanced oily water treatment equipment operation troubleshooting.
- Advanced oily water compliance testing and troubleshooting.
- HAZOPS site audit.
- Detailed water analysis (may include drop size, chemistry, turbidity).
- Specialist water sampling. May include preparation of samples for external analysis.
- Training for maintenance and operations personnel.
- Review of site specific maintenance documentation.



4.4 As Required Service and Maintenance

Some aspects of service and maintenance need to be carried out as soon as an issue is identified and operators must not wait for scheduled or programmed maintenance. This section addresses these matters.

4.4.1 Oil Storage and Decant Tank

Once every 12 months (or sooner if required) the Oil Storage and Decant tank (OSD) MUST be fully drained and cleaned. Solids and scum will build up in the bottom of the tank and this must be periodically removed for the oil collection and decant tank to work effectively.

Emptying the decant tank:

- Using the tank drain valve pump out the entire contents of the tank.
- Rinse out the tank to clear any remaining waste off the walls or sludge on the bottom of the tank.
- Refill the tank with clean water until you see water running out the tank overflow.

Important Note

- The OSD Tank must be emptied when the level indicates that it is required OR at least once every 12 months.
- When cleaning out the OSD tank completely empty all the contents of the tank.

4.4.2 Air Operated Diaphragm Pump Wear

The systems pump is a wearing item that will require periodic maintenance or replacement. This section provides guidance with assessing pump wear.

If any of the following situations occurs that pump may be worn or damaged and **must** be replaced:

- Separator inlet pressure drops below 300 kPa
- Water present in pump exhaust
- Air present in reject or treated water stream
- Uneven beating of pump

If the pump is not operating properly then the separator will not be separating oil as required and risk of non-compliant treated water discharge.

4.4.3 Adjusting the Pneumatic Filter-Regulator Control Circuit

1. Ensure that the plant air compressor is operational.
2. Open the main compressed air inlet valve on the Ultraspin Separator filter-regulator.
3. Ensure that there is sufficient water level in the collection pit to ensure that both the low and high level floats are actuated (in the up position) in order to operate the pneumatic circuit on the Ultraspin Separator
4. Wind in the regulator to the lowest possible pressure (normally zero pressure).



5. Adjust the pneumatic regulator on skid until the pressure gauge on the filter-regulator reaches 550 kPa.
6. Air will now flow to the pump via the filter-regulator.
7. The pump should commence pumping (quickly at first while priming, and then beating smoothly and rhythmically when pumping liquid).
8. Check for any air or water leakage and tighten fittings as required.
9. Adjust the filter/regulator to give the correct separator pump discharge pressure of about 400 kPa (average between pulses).

4.4.4 Adjustment of Pneumatic Timer

If additional oil removal or oily water treatment performance is required the recycle time can be increased by adjusting the pneumatic/mechanical timer.

The oily water collection pits must be sufficiently sized to accommodate additional surge capacity, as during the entire recycle phase no water will be discharged and the water level in the pit will not drop.

- Remove lid on weatherproof box on the separator skid that contains pneumatic timer.
- Ensure that the timer is set to required time; typically, this is 30 minutes.

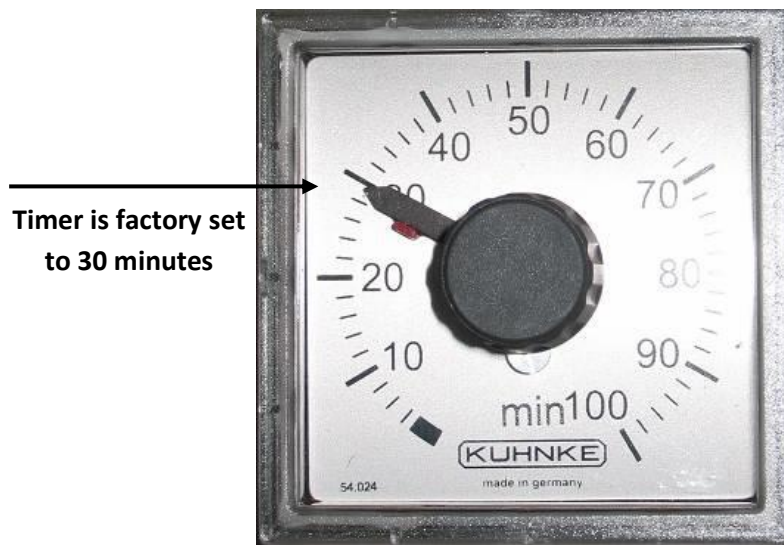

4.4.5 Collection Pit Desludging

In most installations, the untreated oily water flows from source first to one or more effluent collection pits. These pits will accumulate suspended solids and sludge. Operators will need to remove sludge and clean pits when:

- Sludge build-up is might interfere with the skimmer operation
- Sludge volumes compromise the effective working capacity volume of the pits
- Scheduled cleanouts

For correct OWS system performance and to achieve the desired water quality results, the following pit pump out procedure must be followed.

1. Immediately before the pit is pumped out, the main isolator on the Ultraspin control box must be turned OFF.
2. Ultraspin recommend that after a pit pump out the pits must be refilled with fresh water.
3. After the pits are refilled, switch the main isolator on the Ultraspin control box ON.

If separator switched ON with insufficient water in either pit, the separator pump will run dry and system will shut down on low pressure/flow.

5 Troubleshooting Matrix

No	Problem	Possible Cause/Problem	Suggested Action
1	Low or no Ultraspin reject (oil/water) flow	<p>Ultraspin reject orifice blocked</p> <p>Treated water outlet orifice is missing</p> <p>Low Pump Flow</p>	<p>Shut system and use de-blocking tool to clear blockage. Important: Shut unit off before removing the reject cap. Replace before restarting.</p> <p>Replace treated water outlet orifice</p> <p>See 4.</p>
2	High Ultraspin Reject Flow	<p>Ultraspin underflow blocked</p> <p>Reject O-Ring Seal is missing</p> <p>Clean water outlet piping is blocked</p> <p>Ultraspin inlet head not installed correctly</p>	<p>Shut system down, unscrew outlet union and clear blockage, ensuring plastic back-pressure orifice is replaced.</p> <p>Shut down system, de-pressurise and replace liner O-rings.</p> <p>Clear the Ultraspin clean water outlet pipes (recycle and discharge lines).</p> <p>Remove Ultraspin inlet head and re-install correctly. Check for missing O-rings.</p>
3	Poor Oil Separation Performance	<p>Needs a further recycle</p> <p>Low or no reject flow</p> <p>Low pump flow</p> <p>Chemicals, e.g. Detergent or Glycol, in the pit</p> <p>Skimmer needs cleaning</p> <p>Oil collection pit/vessel full</p> <p>Blockage in the underflow piping or Ultraspin</p>	<p>Complete another recycle sequence of the system (i.e. restart Ultraspin).</p> <p>See 1.</p> <p>See 4</p> <p>Pump out, clean and flush pit. Investigate how these chemicals entered the pit and take action to prevent further ingress.</p> <p>Adjust or clean skimmer.</p> <p>Empty or pump out oil collection vessel.</p> <p>See 2</p>

4	Low pump flow	Low air supply pressure/volume	Check compressor setting. Check for blockages or restrictions in air supply lines.
	a. Pump operating too slowly (< 55 beats/min)	Pump regulator pressure adjusted too low	Readjust with pump operating to about 55 beats per min.
		Blocked pump suction strainer	Clean Strainer. See 2.
	b. Pump operation erratic	Blockage in the underflow piping or Ultraspin	Check compressor operation and water drains in air lines. See Pump manual.
		Poor air quality (i.e. wet air)	Check for leaks in the strainer lid, skimmer, or pump suction piping.
	High pump flow	Other pump problems	Backflush line, check for blockage in skimmer or hose.
	a. Pump operating too fast (> 60 beats/min)	Pump not priming	Pit empty (manual control not turned off), Low level switch failed to shut unit off (see 5.0).
	Blocked suction line	Remove skimmer from obstruction in pit and rectify to prevent reoccurrence.	
	Skimmer running dry	Remove skimmer from obstruction in pit and rectify to prevent reoccurrence.	
5	Separator not auto starting	Air not turned on	Open air valve or start compressor
		Level switch not functioning	Check that nothing (including skimmer) is obstructing high level float Check valves (x 2) inside switch box are not jammed.
6	Separator not auto stopping	Level switch not functioning	Check nothing (including skimmer or built up silt) is preventing low level ball dropping. Check valves (x 2) inside switch box are not jammed.
7	Reset system	If the water level is still between the high and low level floats when the air supply is isolated	Turn air supply back on (system will start). Manually push both high and low level floats down. This will stop the pump and reset the valve and timer.
8	No Decant Water Flow from Oil Tank	No Reject	See1
		Oil Tank Water Decant blocked Oil Tank filling	Clean. Wait for tank to fill up.
9	Other	Consult Ultraspin	Contact Ultraspin.

6 Drawings Schedule

For the Ultraspinn Oily Water Separator drawings, please refer to Appendix 7.7

7 Appendices

- Appendix 1 – Operation Checklist
- Appendix 2 – Separator Liner Reject Orifice Wear
- Appendix 3 – Sampling Procedure
- Appendix 4 – Performance Factors
- Appendix 5 – Spare Parts Lists
- Appendix 6 – Equipment Data Sheets
- Appendix 7 – Process and Mechanical Drawings

7.1 Appendix 1 – Operation Checklist

#	Check	Result	Correct Operating Condition
1	Pump discharge / Separator Inlet Pressure	_____ kPa	<ul style="list-style-type: none"> Must be within the range 350 to 550 kPa The Pump must be running smoothly, no unusual noises <p>ACTION: If the pump pressures are outside the range above it is indicating a fault. You should conduct a MINOR service immediately or contact Ultraspın for further advice.</p>
2	Separator Outlet Pressure	_____ kPa	<ul style="list-style-type: none"> Must be within the range 100 to 200 kPa
3	Oil Reject Flow ⁽¹⁾	Yes / No	<ul style="list-style-type: none"> Is the oily water reject flowing as expected? Temporarily remove the push fit reject line to inspect the reject flow. Re-attach when completed. <p>ACTION: If the oil reject is not flowing it is indicating a fault. You should conduct a MINOR service immediately or contact Ultraspın for further advice.</p>
4	Oil Skimmer Operation	Yes / No	<ul style="list-style-type: none"> No debris blocking flow Evenly distributed flow across the donut shaped weir. <p>ACTION: Clear any blockage</p>
5	Oil & Decant Tank	Full: Yes / No	<ul style="list-style-type: none"> NOT full of oil Use dipstick, water finding paste, or level indicators <p>ACTION: If the check indicates the tank is full of oil you will need to arrange a tank pump out immediately. If the tank is full of oil the Ultraspın separator is not able to store the separated oil and the water discharge quality will not be acceptable.</p>
6	Debris Strainer	Emptied: Yes / No	<ul style="list-style-type: none"> Check and empty the debris strainer basket. Cleaning frequency will depend on the trash load allowed to arrive in the collection pits.

If there appears to be any problem with any part of this routine operating check contact service and maintenance personal OR Consult Ultraspın for more help.

7.2 Appendix 2 – Separator Liner Reject Orifice Wear

The Ultraspin separator liner is made from high wear resistant materials. However, velocities in some regions of the separator exceed 15 m/sec and over time some wear is inevitable.

7.2.1 Liner Head Wear

This wear occurs first in the reject hole area of the head section of the separator liner. For proper operation of the oil separator it is important that the head section is replaced when the outside diameter of the reject (as measured on the end face) exceeds 6.5 mm. When the reject hole at the end face is more than 6.5 mm the separator will no longer be functioning correctly and the water will not be treated properly.

If the liner head is found to be worn it **must** be replaced before the Ultraspin Oily Water Separator is put back into service.

Measuring the wear of the head is easy. Ultraspin has a simple test kit for this purpose as shown in the photos below.

Use the following procedure to determine if you need to replace head section:

1. Remove liner from the vessel
2. Carefully unscrew the head section from the liner
3. Clean the head section with water then dry thoroughly
4. Using the Ultraspin wide tipped marking pen swipe across reject orifice on the inside face of the liner head with mild pressure. Don't press too hard. Mild pressure can be applied by holding the pen between thumb and one finger. It may be necessary to swipe in a few different directions



5. Insert the pin tool into the centre of the reject orifice of the head. See the pictures below



6. If you can see any white rimmed areas outside the pin then the liner reject orifice is worn and the head section must be replaced from the Minor Service Parts Kit
- Once the Pin Tool has been inserted into the inside of the liner head it will be clear if there is any excessive wear to the reject orifice. Indicated by a visible white unmarked rim around the pin tool.
 - See below of examples of 'Passed' and 'Failed' liner heads.
7. If the liner head passes the assessment then it can be reinstalled on to the liner body and refitted into the separator vessel, using the reverse of the instructions above.
8. If the liner head fails the wear assessment it must be replaced before the Ultraspin Oily Water separator is put back into service
9. Risk of non-complaint discharge if the system is run with worn separator liners.

Important Note

- The new Liner Head from the Minor Service Parts Kit must be threaded tightly onto the main body of the liner until the internal faces meet with no gap, this is **vitaly important**

7.2.2 Separator Liner Wear

Eventually wear occurs along the entire length of the liner. This is difficult to measure in the field. Experience has shown that the entire liners will need to be replaced every:

- 3 years
- OR
- 10,000 hours of actual operation; whichever occurs first.

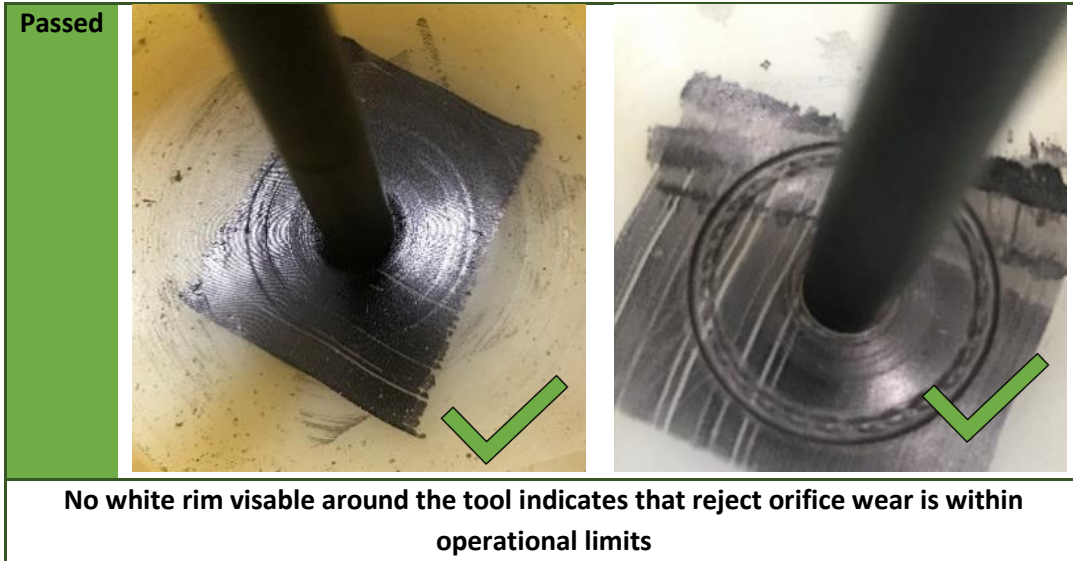

7.3 Appendix 3 - Sampling Procedure

How to Sample Oily Water

 **Safety First**
Check with the relevant personnel that it's safe and wear any necessary PPE

 **Pre Prepared Sample Bottle**
1L labelled wide-mouthed clear glass bottle with a Teflon coated lid
Cleaned with hot water and detergent, rinsed with water, rinsed with an appropriate solvent and acidified

Step 1 Open the sample valve completely (full bore) and allow it to flush for 2 minutes. This will clear out oil, solids and silt that accumulates over time behind the valve



2 mins

Step 2

Close the valve to a level you are comfortable with for the sampling. Don't adjust the valve until the sampling is complete as this can dislodge debris

Step 3 Place jar under the flow and fill to around 90% full. Do not overfill – oil floats and will be lost if you overfill the jar. Remove the jar out of the stream BEFORE you close the sample point



Step 4



Lid tightly and refrigerate as soon as possible if not analysing the sample within 2 hours

For more information on proper oily water sampling procedure, please refer to the video below.

 For an on-site video of the proper oily water sampling technique, visit <https://www.youtube.com/watch?v=G5KgsE-N5dE>

7.4 Appendix 4 - Factors Affecting Oil Water Separation Performance

There are many factors that affect the performance of an installed oily water separator system. Many of these factors are within the control of and are the responsibility of the customer. Others are related to the equipment and equipment selection and may be the responsibility of the equipment vendor.

Customers do not always understand the factors and often take a simplistic approach by only considering factors related to equipment.

Oily water is a specialised area and many times customers do not have the expertise to understand all the factors within their control. Ultraspin can help by providing training and issue certificates of competence.

When we are contacted to address an OWS issue we investigate all factors as any area could be the source of the problem.

7.4.1 How Can Ultraspin Help

- Provide education to the people responsible for managing and maintaining the system.
- Provide OEM compliant service and maintenance programs.
- Provide site audit, sample collection and analysis services.
- Provide certified training on:
 - Oily water science to better manage Oily Water Separation
 - How to make sure laboratories are performing applicable analysis
 - Correctly collecting samples.
 - Site Audits.
 - Service and Maintenance details.

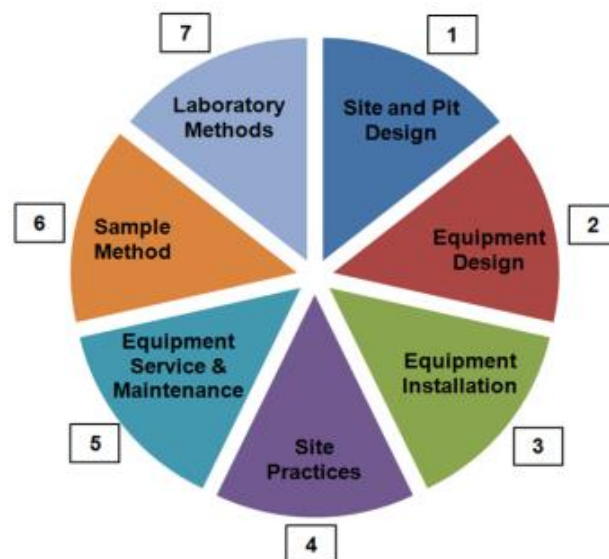

7.5 Appendix 5 - Spare Parts List



Spare Parts List SP002 - PC35-AR

Rev 0
Date: 24/11/17

Minor Service Spare Parts

The following spare parts must be replaced during the Minor Service

Description	Part No.	Qty.
O-ring Kit: Ultraspin deoiler liner (SUBLN040)	ORNKIT-07	1
Standard Capacity liner head (SUBLN040)	LIN070	TBC*

**Item is only required as per the results of the Liner Inspection Test*

Major Service Spare Parts

The following spare parts must be replaced during the Major Service

Description	Part No.	Qty.
S1 Skimmer Internals Replacement Kit - donut, bellows, rings and clamps	SUBSK026	1
O-ring Kit: Pneumatic and Electric 3.5 m ³ /hr single stage systems	ORNKIT-03	1
Auto-Recycle Pneumatic Filter Regulator (3.5m ³ /hr rated)	SUBOS012	1
Ultraspin standard capacity deoiler liner	SUBLN040	1

Other Spare Parts

Customers may choose to purchase the following parts to:

- Upgrade the equipment to suit their application
- Hold onsite to ensure parts are readily available
- Replace items in the event they become damaged

Description	Part No.	Qty.
Air operated diaphragm pump (1- 1/2"), aluminium / nitrile, inc muffler	PMP074	1
Air Side Repair Kit: diaphragm pump (1- 1/2")	PMP265	1
Wet Side Repair Kit: diaphragm pump (1- 1/2")	PMP266	1
Pneumatic Auto-Recycle Timer Assembly	SUBOS023	1
Pneumatic spring return actuator (90 deg clockwise rotation)	VLV179	1
Pneumatic Level Switch components	LVL008	1
Pressure gauge 0-1000 kPa 1/2 inch BSPT (m) bottom entry (304 SS)	INT041	1
Oil level indicating dip stick (SS304)	FAB832	1



Spare Parts List SP004 - PB35-AR

Rev 0
Date: 24/11/17

Minor Service Spare Parts

The following spare parts must be replaced during the Minor Service

Description	Part No.	Qty.
O-ring Kit: Ultraspin deoiler liner (SUBLN040)	ORNKIT-07	1
Standard Capacity liner head (SUBLN040)	LIN070	TBC*

**Item is only required as per the results of the Liner Inspection Test*

Major Service Spare Parts

The following spare parts must be replaced during the Major Service

Description	Part No.	Qty.
S1 Skimmer Internals Replacement Kit - donut, bellows, rings and clamps	SUBSK026	1
O-ring Kit: Pneumatic and Electric 3.5 m ³ /hr single stage systems	ORNKIT-03	1
Auto-Recycle Pneumatic Filter Regulator (3.5m ³ /hr rated)	SUBOS012	1
Ultraspin standard capacity deoiler liner	SUBLN040	1

Other Spare Parts

Customers may choose to purchase the following parts to:

- Upgrade the equipment to suit their application
- Hold onsite to ensure parts are readily available
- Replace items in the event they become damaged

Description	Part No.	Qty.
Air operated diaphragm pump (1- 1/2"), aluminium / nitrile, inc muffler	PMP074	1
Air Side Repair Kit: diaphragm pump (1- 1/2")	PMP265	1
Wet Side Repair Kit: diaphragm pump (1- 1/2")	PMP266	1
Pneumatic Auto-Recycle Timer Assembly	SUBOS023	1
Pneumatic spring return actuator (90 deg clockwise rotation)	VLV179	1
Pneumatic Level Switch components	LVL008	1
Pressure gauge 0-1000 kPa 1/2 inch BSPT (m) bottom entry (304 SS)	INT041	1

7.6 Appendix 6 - Equipment Data Sheets



SEPARATOR SYSTEM EQUIPMENT DATA SHEET

		Units	Data	Rev
DESCRIPTION				
1	Manufacturer		Ultraspin Technology Pty. Ltd	0
2	Separator type		Hydrocyclone	0
3	Model		PC35-PB35	0
4	Nominal capacity (inlet flow)	m ³ /hr	3.5	0
SERVICE REQUIREMENTS				
5	Environment	Indoors/Outdoors/Undercover	Indoors/Outdoors/Undercover	0
6	Ambient temperature range	°C	Ambient in full sun	0
7	Nominal design life	years	20	0
8	Drive type	Pneumatic/Electric	Pneumatic	0
9	Maximum noise pressure level	dBA @ 1m	<70	0
10	Air Quality		Clean, Filtered Compressed Air	0
11	Nominal air usage at 450kPa pump discharge pressure	scfm	20	0
12	Nominal typical compressor capacity	scfm	29	0
13	Required compressed air inlet pressure	kPa	800	0
INTAKE FLUID				
14	Fluid temperature range	°C	5-45	0
15	Fluid pH range		5 to 9	0
SYSTEM COMPONENTS (OIL-WATER SEPARATOR)				
OIL-WATER SEPARATOR STRAINER				
16	Strainer type		Housing with strainer basket	0
17	Strainer size	dia / H mm	350 / 600	0
18	Trash holding capacity	L	7	0
19	Screen type		Easy clean perforated sheet	0
20	Screen size	mm	3	0
21	Strainer lid opening		Quick opening eye bolts on flange end	0
22	Material of construction		Stainless steel 304	0
23	O-rings material of construction		Buna-N	0
24	Pressure rating	kPag	-80	0
OIL-WATER SEPARATOR PUMP				
25	OWS pump type		Air operated double diaphragm	0
26	Nominal rated capacity at operating point (flow / head)	m ³ /hr / m	3.5 / 40	0
27	Duty point		Refer to pump curve	0
28	Self Priming	Y / N	Y	0
29	Maximum allowable suction lift			0
30	NPSHA		Please consult pump manufacturer's data in conjunction with proper site design	0
31	NPSHR			0
32	Maximum discharge head			0
OIL-WATER SEPARATOR VESSEL				
33	Number of oil-water separator vessels		1	0
34	Material of construction		Stainless Steel 304	0
35	O-rings material of construction		Buna-N	0
36	Arrangement		Horizontal shell with holding plates	0
37	Design code		AS4041 Class 3	0
38	Vessel class		Class 3	0
39	Hazard level		E	0
40	Design Pressure	kPag	600	0
OIL-WATER SEPARATOR LINERS				
41	Number of cyclones in separator #1 / type		x1 / Standard capacity	0
42	Material of construction		UHMWPE (10 million g/mol)/Stainless steel 316	0
43	O-rings material of construction		Viton	0
44	Concentrated hydrocarbon outlet connection size (reject)	mm	4.5	0
45	Nominal capacity per liner	m ³ /h	3.5	0
46	Nominal pressure drop per liner (inlet to treated water outlet)	kPag	300 (at nominal flow)	0
RECYCLE / DISCHARGE VALVE (OPTIONAL - IF FITTED)				
47	Valve material of construction		Stainless Steel 316	0
48	Valve type		3-way L-port	0
49	Actuator details		Pneumatically actuated	0
50	Actuator materials of construction		Anodised Aluminium	0

Notes:

- 1) This document should be read in conjunction with the relevant Ultraspin drawings
- 2) This is typical data only and is subject to change without notice
- 3) If there is any discrepancy between the drawings and this data sheet please notify Ultraspin immediately

REV	Description of Changes	Prepared by	Approved by	Date
A	Document created	ZV	IS	1/02/2018
0	Updates for clarity	ZV	IS	14/05/2018



SEPARATOR SYSTEM EQUIPMENT DATA SHEET

		Units	Data	Rev
OIL STORAGE AND DECANT TANK (CUBE UNITS ONLY)				
51	Nominal capacity	L	1,000 L	0
52	Tank material of construction		Stainless Steel 304	0
53	Internal tank piping material of construction		PVC/Viton/Stainless steel 316	0
54	Vent		Vented lid	0
55	Access Opening	mm	300	0
INSTRUMENTATION AND CONTROLS				
56	Flow control		Orifice plate/Hose	0
57	Recycle timer		0-90min (set to 30min)	0
58	Sampling points	1	Intake Oily Water	0
59	Sampling points	1	Treated Water Outlet	0
OIL-WATER SEPARATOR SKID ARRANGEMENT				
60	<i>Items on Skid</i>			0
61	OWS Skimmer	Y / N	N	0
62	Separator pump	Y / N	Y	0
63	Back-Up Strainer	Y / N	Y	0
64	Oil Water Separator	Y / N	Y	0
65	Controls and MCC	Y / N	Y	0
PIPING SPECIFICATIONS				
66	Piping Specification		Ultraspin US1	0
67	Design Standard		AS4041 Class 3	0
68	Piping Pressure Rating	kPag	1000	0
69	Piping Class		3	0
70	Valve Types		Ultraspin US1	0

Notes:

- 1) This document should be read in conjunction with the relevant Ultraspin drawings
- 2) This is typical data only and is subject to change without notice
- 3) If there is any discrepancy between the drawings and this data sheet please notify Ultraspin immediately

REV	Description of Changes	Prepared by	Approved by	Date
A	Document created	ZV	IS	1/02/2018
0	Updates for clarity	ZV	IS	14/05/2018

7.7 Appendix 7 - Process and Mechanical Drawings

CONFIDENTIAL
NOT FOR CONSTRUCTION

ULTRASPIN OIL
SKIMMER
MODEL: S1

ULTRASPIN OIL
SEPARATOR
MODEL: PC35

OIL STORAGE +
DECANT TANK

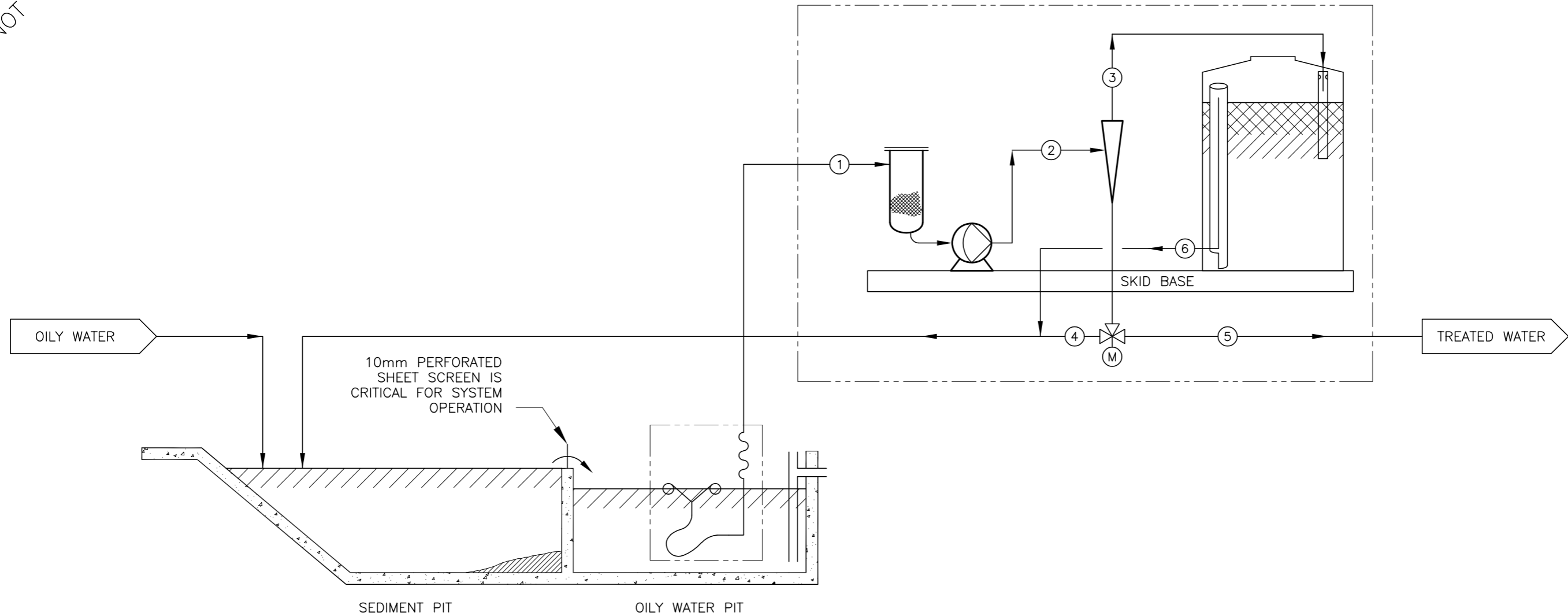

PARAMETER (NORMAL OPERATING CONDITIONS)	STREAM ID					
	1	2	3	4	5	6
	SKIMMED OILY WATER	DEOILING SEPARATOR FEED	DEOILING SEPARATOR REJECT	RECYCLE RETURN TO PIT	TREATED WATER	DECANT WATER
PRESSURE (kPa)	-30	400	5	180	180	5
FLOW RATE (m ³ /h)	3.5	3.5	0.2	3.3	3.3	0.2

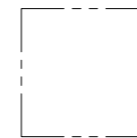

DENOTES ULTRASPIN SCOPE
OF SUPPLY.

GENERAL NOTES

1. ANY INTERCONNECTING PIPING IS NOT PART OF ULTRASPIN SUPPLY
2. SITE PIPING TO BE FREE DRAINING; NO RESTRICTIONS
3. OUTLET PIPING TO BE FREE DRAINING; NO RESTRICTIONS
4. PUMP SUCTION MAX LENGTH 15m AND MAX VERTICAL RISE 2m

REV	DESCRIPTION	DRAWN	CHKD	DATE	DIMENSIONS IN MILLIMETRES UNLESS OTHERWISE STATED
0	ISSUED FOR INFORMATION	L.P.	-	13.11.18	IF IN DOUBT ASK DO NOT SCALE
					THIRD ANGLE PROJECTION UNLESS OTHERWISE STATED



ULTRASPIN PTY LTD
46 WADHURST DRIVE, BORONIA, VIC. 3155
PH 61 3 8841 7200

THIS DRAWING IS THE PROPERTY OF ULTRASPIN AND MUST NOT BE USED OR
COPIED WITHOUT THEIR WRITTEN PERMISSION. FEATURES OF THE ULTRASPIN PRODUCTS
AND PROCESS SHOWN ARE PATENTED OR PATENT PENDING. PROCESS AND EQUIPMENT
DESCRIBED SHOULD NOT BE USED WITHOUT PRIOR WRITTEN CONSENT FROM
ULTRASPIN
TM—TRADE MARK OF ULTRASPIN Pty Ltd

CONFIDENTIAL

TITLE
OILY WATER TREATMENT SYSTEM
PROCESS FLOW DIAGRAM

CLIENT
TYPICAL

SCALE	SIZE	DOC No.	SHEET	REV
-	A3	PC35-AR-PFD	1 of 1	0

CONFIDENTIAL
NOT FOR CONSTRUCTION

ULTRASPIN
OIL SKIMMER
MODEL: S1

DEBRIS STRAINER
3mm PERFORATION

SEPARATOR PUMP
AIR OPERATED
DIAPHRAGM PUMP

ULTRASPIN
OILY WATER SEPARATOR
MODEL: PB35-AR

OIL STORAGE AND
DECANT TANK

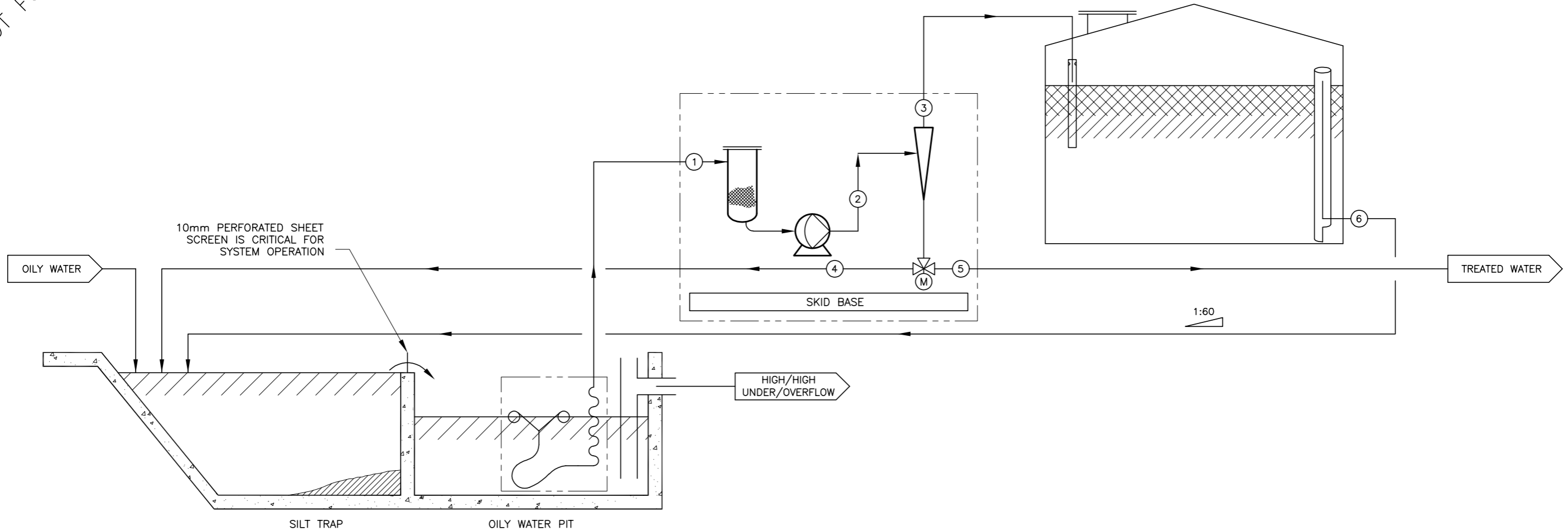

PARAMETER (NORMAL OPERATING CONDITIONS)	STREAM ID					
	1 SKIMMED OILY WATER	2 DEOILING SEPARATOR FEED	3 DEOILING SEPARATOR REJECT	4 RECYCLE RETURN TO PIT	5 TREATED WATER	6 DECANT WATER
PRESSURE (kPa)	-30	400	5	180	180	5
FLOW RATE (m ³ /h)	3.5	3.5	0.2	3.3	3.3	0.2

 DENOTES ULTRASPIN
SCOPE OF SUPPLY.

GENERAL NOTES

1. ANY INTERCONNECTING PIPING IS NOT PART OF ULTRASPIN SUPPLY
2. SITE PIPING TO BE FREE DRAINING; NO RESTRICTIONS
3. OUTLET PIPING TO BE FREE DRAINING; NO RESTRICTIONS
4. PUMP SUCTION MAX LENGTH 15m AND MAX VERTICAL RISE 2m

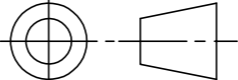
REV	DESCRIPTION	DRAWN	CHKD	DATE	DIMENSIONS IN MILLIMETRES UNLESS OTHERWISE STATED
0	ISSUED FOR APPROVAL	L.P.	-	13.11.18	IF IN DOUBT ASK DO NOT SCALE
					THIRD ANGLE PROJECTION UNLESS OTHERWISE STATED
					

ultraspin
ULTRASPIN PTY LTD
46 WADHURST DRIVE, BORONIA, VIC. 3155
PH 61 3 8841 7200

THIS DRAWING IS THE PROPERTY OF ULTRASPIN AND MUST NOT BE USED OR COPIED WITHOUT THEIR WRITTEN PERMISSION. FEATURES OF THE ULTRASPIN PRODUCTS AND PROCESS SHOWN ARE PATENTED OR PATENT PENDING. PROCESS AND EQUIPMENT DESCRIBED SHOULD NOT BE USED WITHOUT PRIOR WRITTEN CONSENT FROM ULTRASPIN
TM-TRADE MARK OF ULTRASPIN Pty Ltd

CONFIDENTIAL				
TITLE OILY WATER TREATMENT SYSTEM PROCESS FLOW DIAGRAM				
CLIENT TYPICAL				
SCALE	SIZE	DOC No.	SHEET	REV
-	A3	PB35-AR-PFD	1 of 1	0

CONFIDENTIAL
NOT FOR CONSTRUCTION

ITEM NAME: LEVEL SWITCH	ITEM NAME: SEPARATOR PUMP	ITEM NAME: OIL SEPARATOR	ITEM NAME: OIL STORAGE & DECANT TANK
ITEM TAG NO.: LS01	ITEM TAG NO.: PP01	ITEM TAG NO.: PC35	ITEM TAG NO.: TK01
ITEM NAME: S1 OIL SKIMMER	MODEL: PD15A-BAP-GGG	MODEL: PC35-AR	SIZE: 1.0KL
ITEM TAG NO.: SKM01	SIZE: 40 x 40	LINER TYPE: M28SC50 x1	
TYPE: FLOATING SKIMMER WITH WEIR RING & BOTTOM SUCTION	HEAD: 400kPa		
HOSE: 40mm OIL RESISTANT SUCTION	FLOWRATE: 3.5m ³ /h		
ITEM NAME: DEBRIS STRAINER	TYPE: AIR OPERATED DOUBLE DIAPHRAGM		
ITEM TAG NO.: SN01			
MODEL: BFH-1			
HOLE SIZE: ø3mm			
MESH TYPE: PERFORATED SHEET			
RATED CAPACITY: 3.5m ³ /h			

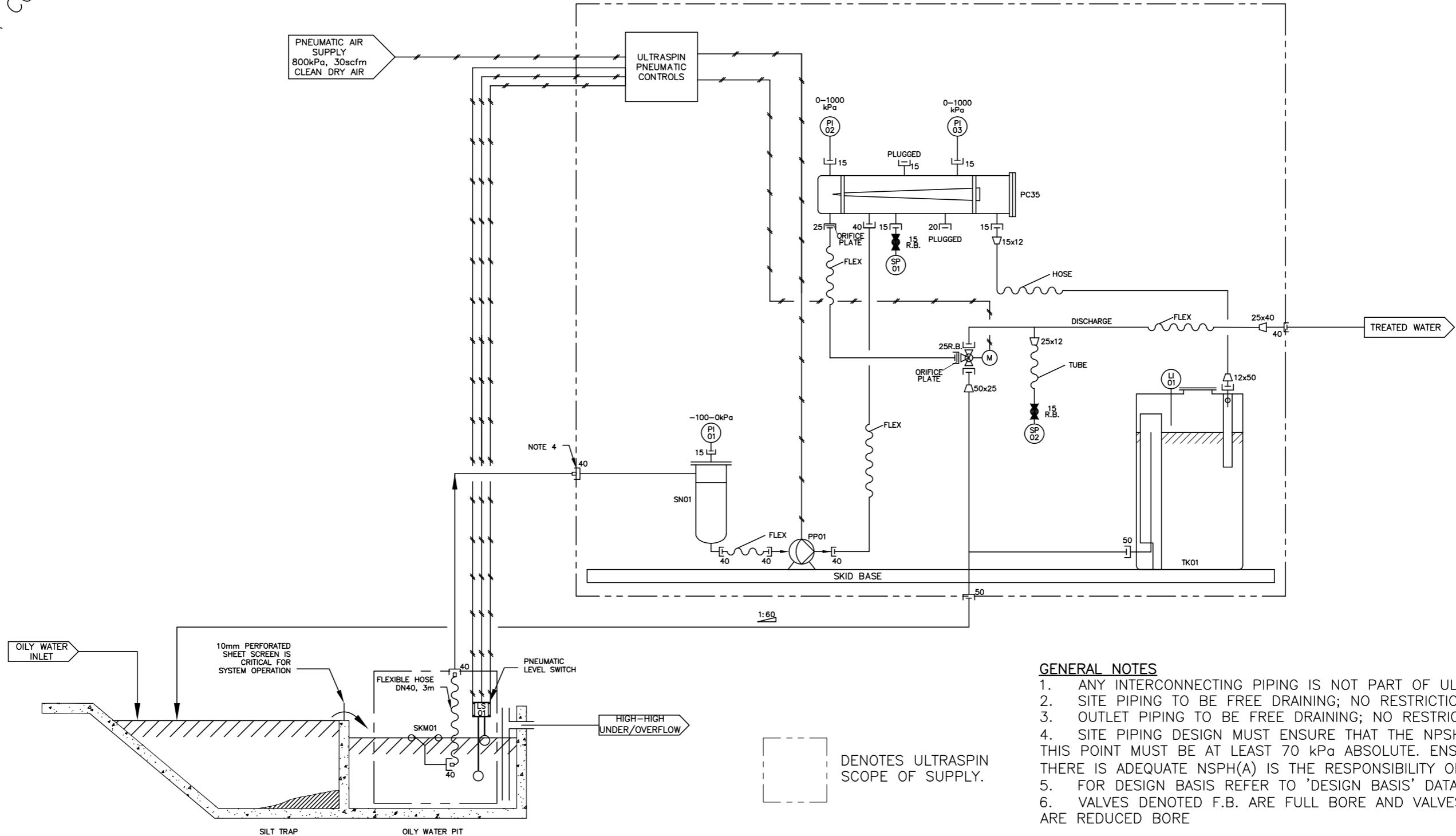

GENERAL NOTES

1. ANY INTERCONNECTING PIPING IS NOT PART OF ULTRASPIN SUPPLY
2. SITE PIPING TO BE FREE DRAINING; NO RESTRICTIONS
3. OUTLET PIPING TO BE FREE DRAINING; NO RESTRICTIONS
4. SITE PIPING DESIGN MUST ENSURE THAT THE NPSH(A) AVAILABLE AT THIS POINT MUST BE AT LEAST 70 kPa ABSOLUTE. ENSURING THAT THE THERE IS ADEQUATE NSPH(A) IS THE RESPONSIBILITY OF SITE DESIGNERS
5. FOR DESIGN BASIS REFER TO 'DESIGN BASIS' DATA SHEET
6. VALVES DENOTED F.B. ARE FULL BORE AND VALVES DENOTED R.B. ARE REDUCED BORE

REV	DESCRIPTION	DRAWN	CHKD	DATE	DIMENSIONS IN MILLIMETRES UNLESS OTHERWISE STATED
0	ISSUED FOR INFORMATION	L.P.	-	15.02.19	IF IN DOUBT ASK DO NOT SCALE
					THIRD ANGLE PROJECTION UNLESS OTHERWISE STATED

ultraspin

ULTRASPIN PTY LTD
46 WADHURST DRIVE, BORONIA, VIC. 3155
PH 61 3 8841 7200

THIS DRAWING IS THE PROPERTY OF **ULTRASPIN** AND MUST NOT BE USED OR COPIED WITHOUT THEIR WRITTEN PERMISSION. FEATURES OF THE ULTRASPIN PRODUCTS AND PROCESS SHOWN ARE PATENTED OR PATENT PENDING. PROCESS AND EQUIPMENT DESCRIBED SHOULD NOT BE USED WITHOUT PRIOR WRITTEN CONSENT FROM **ULTRASPIN**
TM—TRADE MARK OF **ULTRASPIN** Pty Ltd

CONFIDENTIAL				
TITLE OILY WATER TREATMENT SYSTEM PIPING + INSTRUMENTATION DIAGRAM				
CLIENT TYPICAL				
SCALE	SIZE	DOC No.	SHEET	REV
-	A3	PC35-AR-PID	1 of 1	0

CONFIDENTIAL
NOT FOR CONSTRUCTION

ITEM NAME:	LEVEL SWITCH	ITEM NAME:	SEPARATOR PUMP	ITEM NAME:	OIL SEPARATOR
ITEM TAG NO.:	LS01	ITEM TAG NO.:	PU01	ITEM TAG NO.:	OS01
ITEM NAME:	S1 OIL SKIMMER	MODEL:	PD15A	MODEL:	PB35-AR
ITEM TAG NO.:	SKM01	SIZE:	40 x 40	LINER TYPE:	M28SC50
TYPE:	FLOATING SKIMMER WITH WEIR RING & BOTTOM SUCTION	HEAD:	450kPa		
HOSE:	40mm OIL RESISTANT SUCTION	FLOWRATE:	3.5m ³ /h		
		TYPE:	AIR OPERATED DOUBLE DIAPHRAGM		
ITEM NAME:	DEBRIS STRAINER				
ITEM TAG NO.:	SN01				
MODEL:	BFH-1				
HOLE SIZE:	ø3mm				
MESH TYPE:	PERFORATED SHEET				
RATED CAPACITY:	3.5m ³ /h				

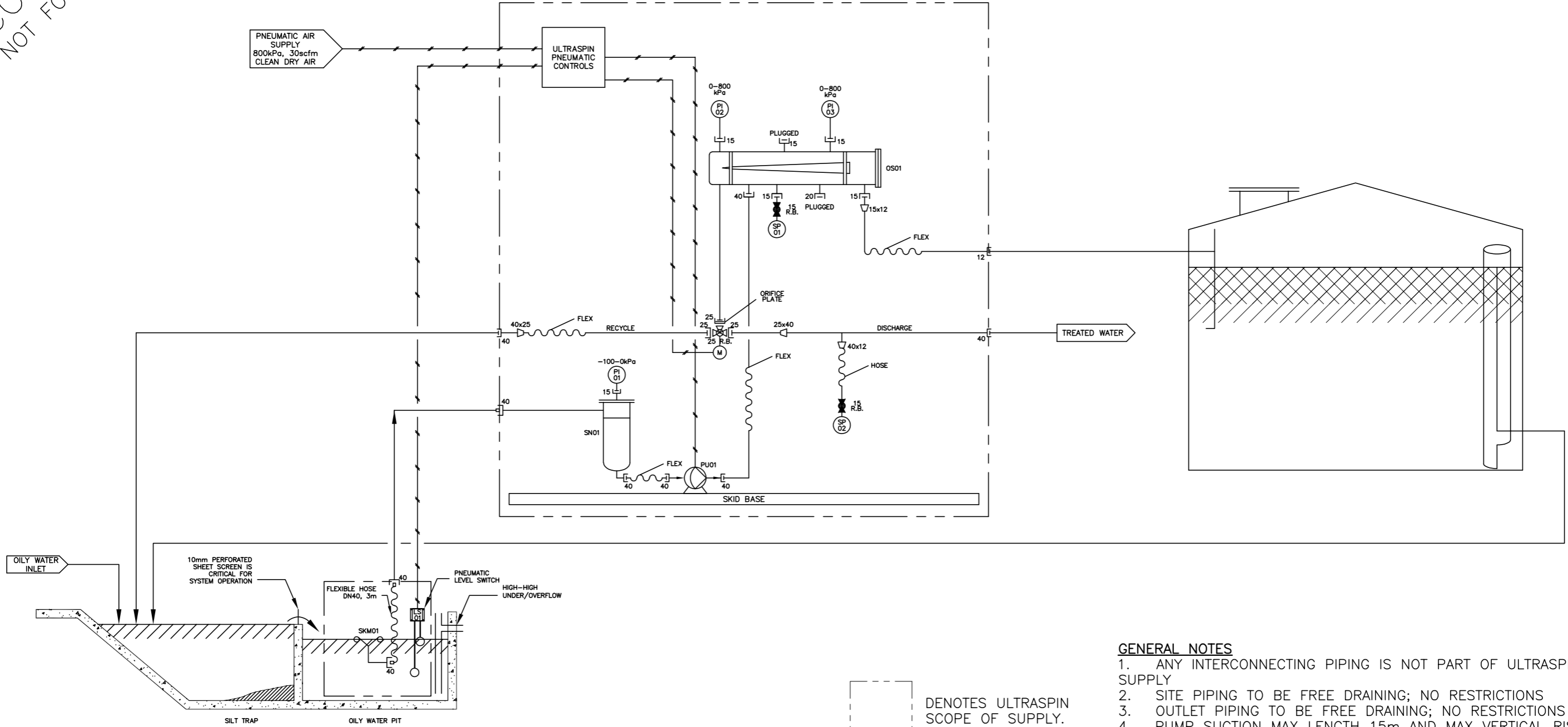

□ DENOTES ULTRASPIN SCOPE OF SUPPLY.

- GENERAL NOTES**
1. ANY INTERCONNECTING PIPING IS NOT PART OF ULTRASPIN SUPPLY
 2. SITE PIPING TO BE FREE DRAINING; NO RESTRICTIONS
 3. OUTLET PIPING TO BE FREE DRAINING; NO RESTRICTIONS
 4. PUMP SUCTION MAX LENGTH 15m AND MAX VERTICAL RISE 2m
 5. VALVES DENOTED F.B. ARE FULL BORE AND VALVES DENOTED R.B. ARE REDUCED BORE

REV	DESCRIPTION	DRAWN	CHKD	DATE	DIMENSIONS IN MILLIMETRES UNLESS OTHERWISE STATED
0	ISSUED FOR INFORMATION	L.P.	-	13.11.18	IF IN DOUBT ASK DO NOT SCALE
					THIRD ANGLE PROJECTION UNLESS OTHERWISE STATED

ULTRASPIN PTY LTD
46 WADHURST DRIVE, BORONIA, VIC. 3155
PH 61 3 8841 7200

THIS DRAWING IS THE PROPERTY OF ULTRASPIN AND MUST NOT BE USED OR COPIED WITHOUT THEIR WRITTEN PERMISSION. FEATURES OF THE ULTRASPIN PRODUCTS AND PROCESS SHOWN ARE PATENTED OR PATENT PENDING. PROCESS AND EQUIPMENT DESCRIBED SHOULD NOT BE USED WITHOUT PRIOR WRITTEN CONSENT FROM ULTRASPIN
TM-TRADE MARK OF ULTRASPIN Pty Ltd

CONFIDENTIAL				
TITLE OILY WATER TREATMENT SYSTEM PIPING + INSTRUMENTATION DIAGRAM				
CLIENT TYPICAL				
SCALE	SIZE	DOC No.	SHEET	REV
-	A3	PB35-AR-PID	1 of 1	0

NOT FOR CONSTRUCTION
LAYOUT & DIMENSIONS SUBJECT TO CHANGE WITHOUT NOTICE

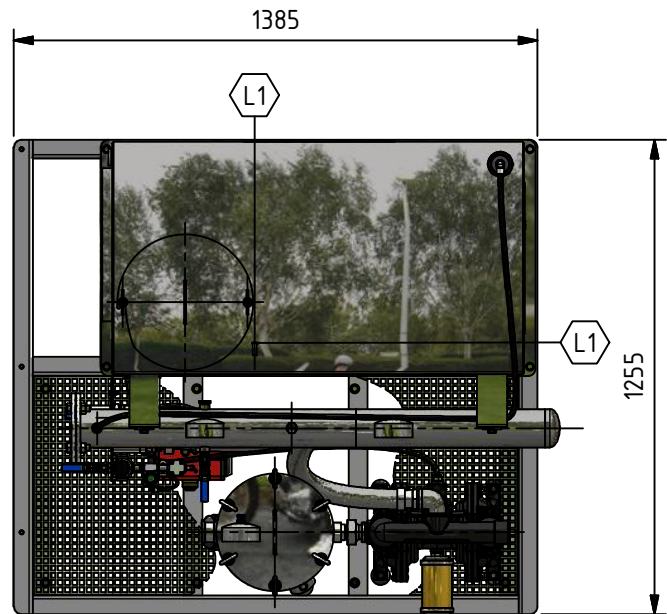

TOP VIEW

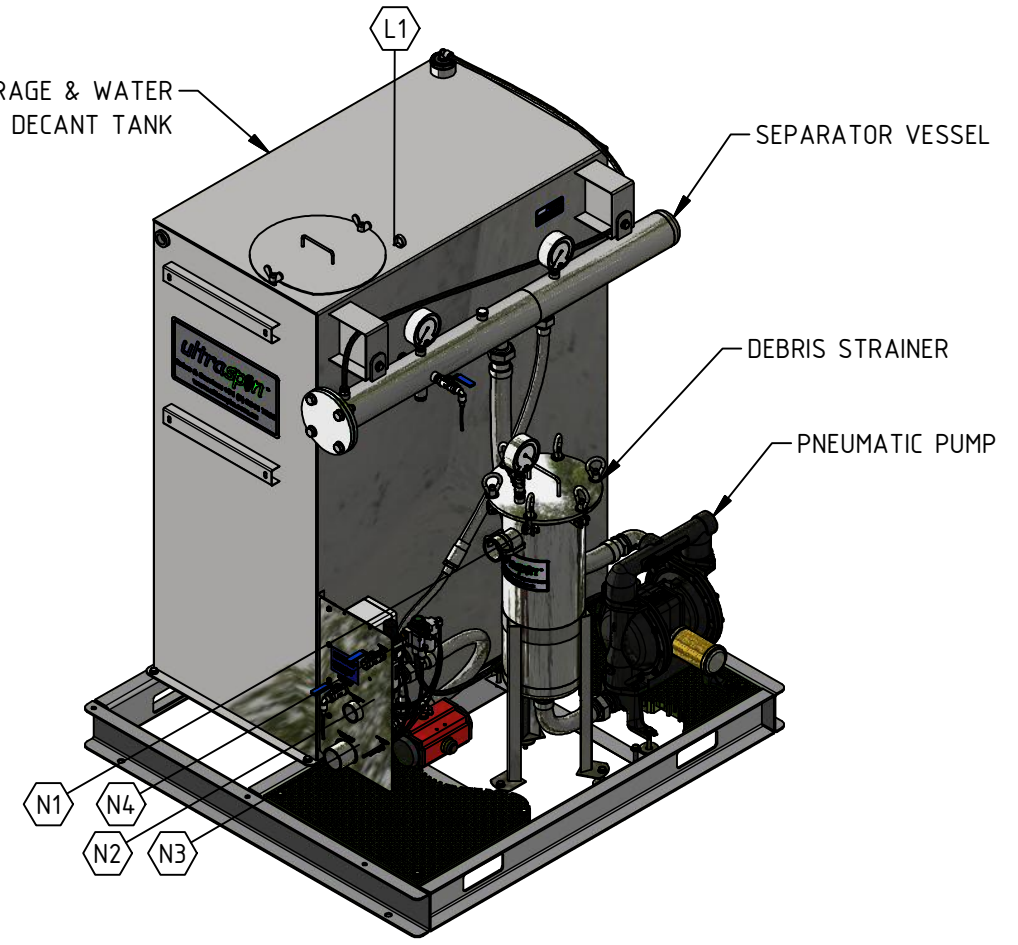

ISOMETRIC VIEW
NTS

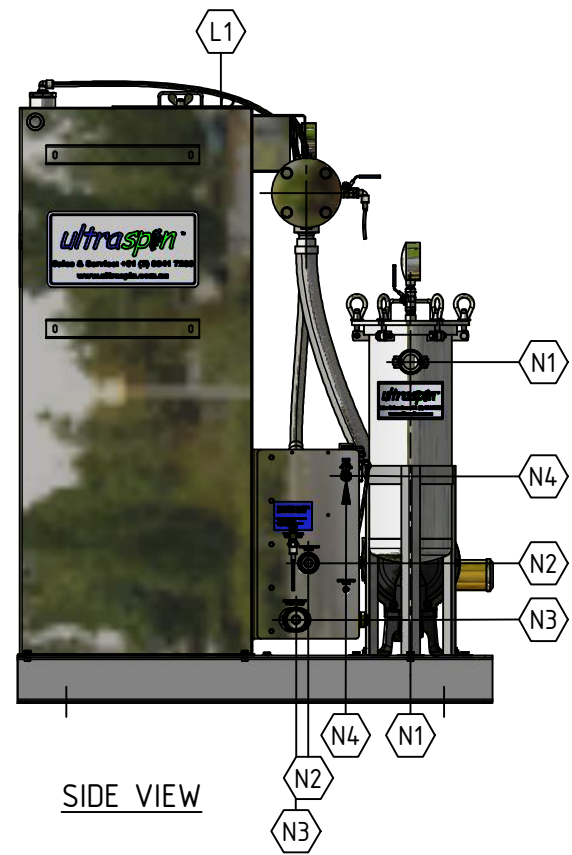

SIDE VIEW

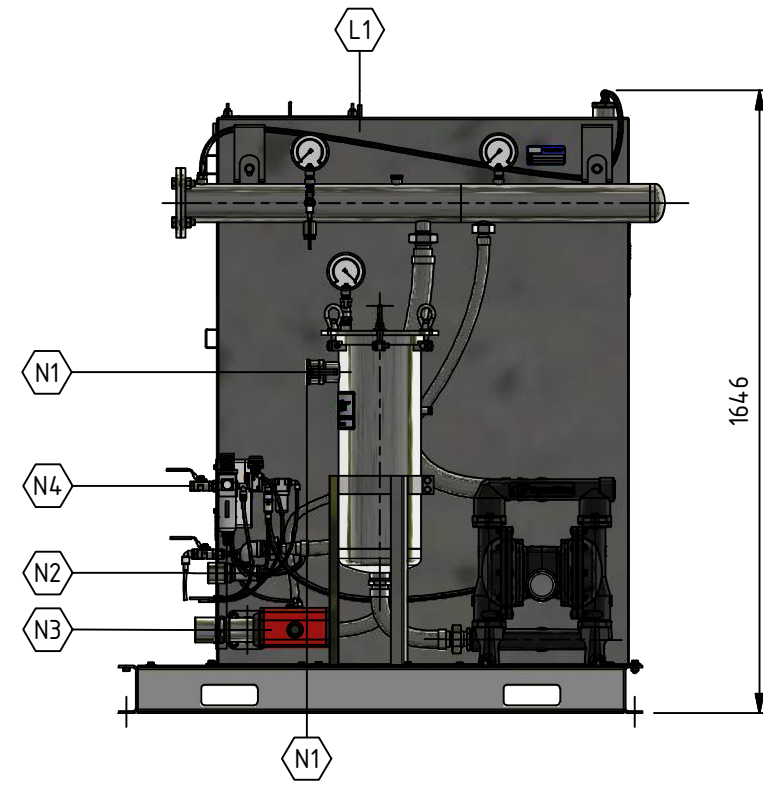

FRONT VIEW

L1	LEVEL INDICATING DIPSTICK
N4	AIR SUPPLY
N3	RECYCLE / DECANT WATER OUTLET
N2	TREATED WATER OUTLET
N1	EFFLUENT INLET
NOZZLE	DESCRIPTION
SITE CONNECTIONS	

REV	DESCRIPTION	DRAWN	CHKD	DATE
H1	CAD MODEL REVISION	GDS	I.S.	11-May-18

DO NOT SCALE
IF IN DOUBT - ASK
UNLESS OTHERWISE STATED
ALL DIMENSIONS IN MILLIMETRES
THIRD ANGLE PROJECTION

CHANGES ON THIS DRAWING MAY BE
RECORDED IN TWO PARTS: eg A1, A2
A,B,C: DENOTES A 3D-CAD CHANGE
1,2,3: DENOTES A DRAWING FACE CHG
THAT DOESN'T AFFECT THE 3D-CAD

ULTRASPIN PTY LTD
46 WADHURST DRIVE, BORONIA, VIC. 3155
PH: +61 3 8841 7200 www.ultraspin.com.au

THIS DRAWING IS THE PROPERTY OF ULTRASPIN AND MUST NOT BE USED OR COPIED WITHOUT THEIR WRITTEN PERMISSION. FEATURES OF THE ULTRASPIN PRODUCTS AND PROCESS SHOWN ARE PATENTED OR PATENT PENDING. PROCESS AND EQUIPMENT DESCRIBED SHOULD NOT BE USED WITHOUT PRIOR WRITTEN CONSENT FROM ULTRASPIN TM-TRADE MARK OF ULTRASPIN Pty Ltd

CONFIDENTIAL				
TITLE 3.5 M ³ /hr OILY WATER SEPARATOR & TANK MODEL: PC35-AR (PNEUMATIC, AUTO RECYCLE)				
CLIENT TYPICAL				
SCALE 1:15	SIZE A3	DRG No. PC35-AR/SD	SHEET 1 of 1	REV H1

NOT FOR CONSTRUCTION
 LAYOUT & DIMENSIONS SUBJECT TO CHANGE WITHOUT NOTICE

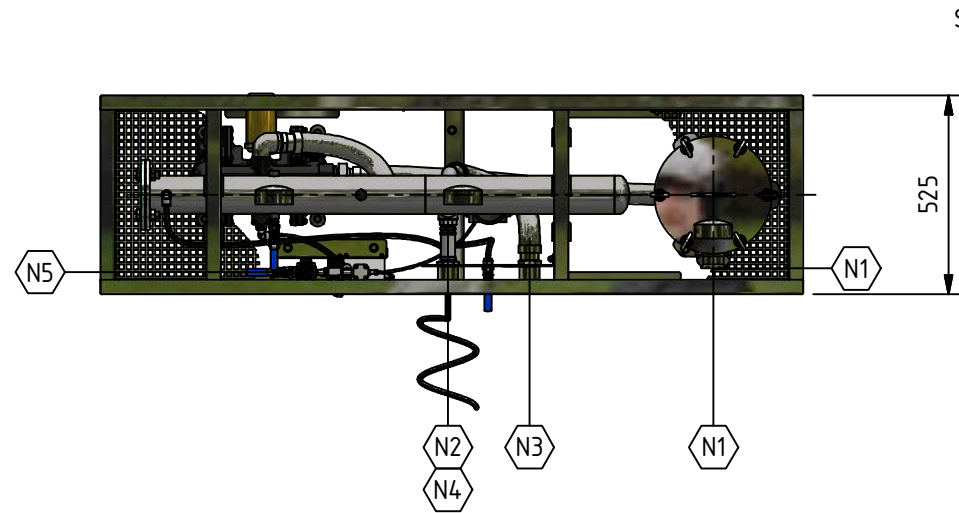

TOP VIEW

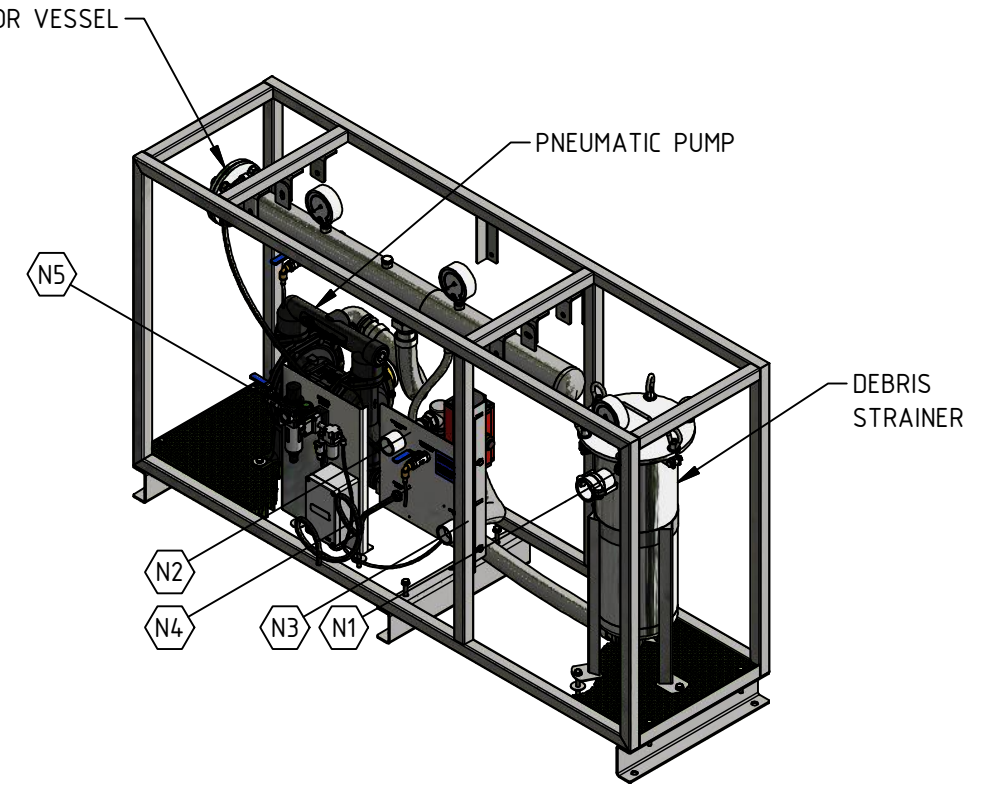

ISOMETRIC VIEW

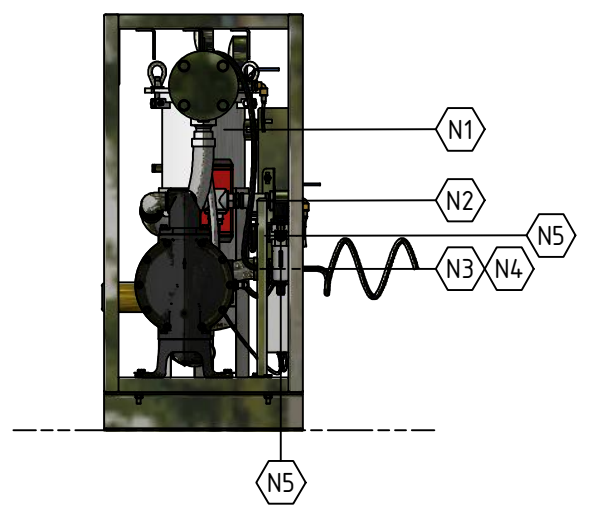

SIDE VIEW

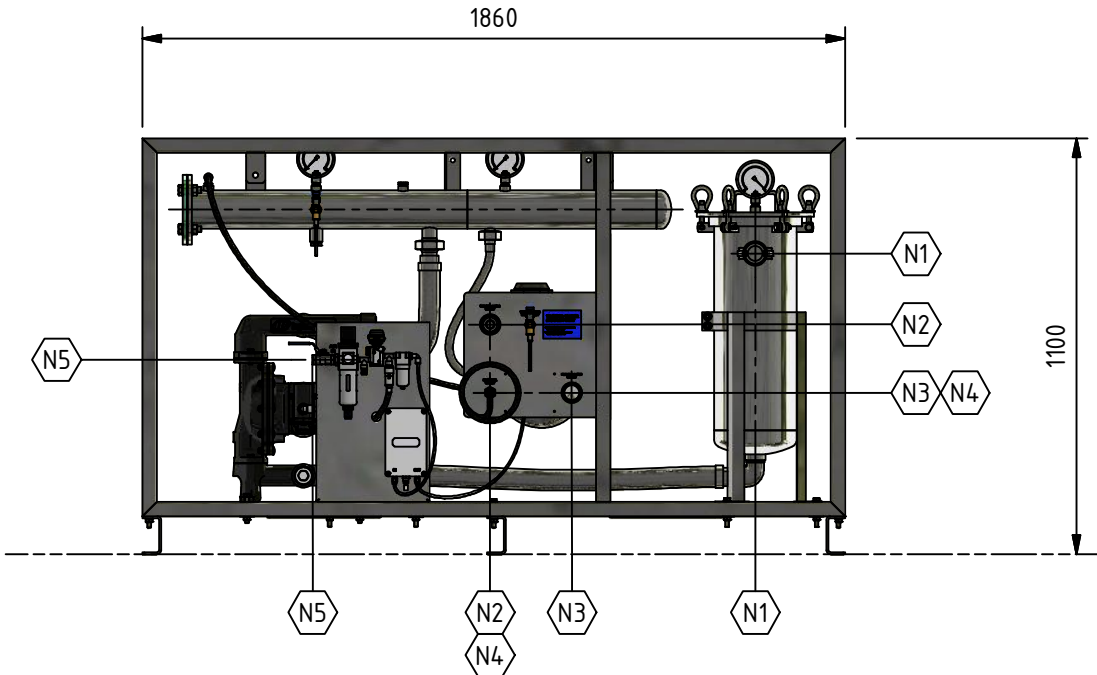

FRONT VIEW

N5	LINE AIR IN
N4	REJECT OIL OUTLET
N3	RECYCLE / DECANT WATER OUTLET
N2	TREATED WATER OUTLET
N1	EFFLUENT INLET
NOZZLE	DESCRIPTION
SITE CONNECTIONS	

REV	DESCRIPTION	DRAWN	CHKD	DATE
B1	CAD MODEL REVISION	GDS	I.S.	17-May-18

DO NOT SCALE
 IF IN DOUBT - ASK

UNLESS OTHERWISE STATED
 ALL DIMENSIONS IN MILLIMETRES
 THIRD ANGLE PROJECTION

CHANGES ON THIS DRAWING MAY BE
 RECORDED IN TWO PARTS: eg A1, A2
 A,B,C: DENOTES A 3D-CAD CHANGE
 1,2,3: DENOTES A DRAWING FACE CHG
 THAT DOESN'T AFFECT THE 3D-CAD

ULTRASPIN PTY LTD
 46 WADHURST DRIVE, BORONIA, VIC. 3155
 PH: +61 3 8841 7200 www.ultraspin.com.au

THIS DRAWING IS THE PROPERTY OF ULTRASPIN AND MUST NOT BE
 USED OR COPIED WITHOUT THEIR WRITTEN PERMISSION. FEATURES OF
 THE ULTRASPIN PRODUCTS AND PROCESS SHOWN ARE PATENTED OR
 PATENT PENDING. PROCESS AND EQUIPMENT DESCRIBED SHOULD NOT
 BE USED WITHOUT PRIOR WRITTEN CONSENT FROM ULTRASPIN
 TM-TRADE MARK OF ULTRASPIN Pty Ltd

CONFIDENTIAL				
TITLE 3.5m ³ /hr "EDGE" OILY WATER SEPARATOR MODEL: PB35-AR (PNEUMATIC, AUTO RECYCLE)				
CLIENT TYPICAL				
SCALE 1:20	SIZE A3	DRG No. PB35-AR/SD	SHEET 1 of 1	REV B1

NOT FOR CONSTRUCTION
 LAYOUT & DIMENSIONS SUBJECT TO CHANGE WITHOUT NOTICE

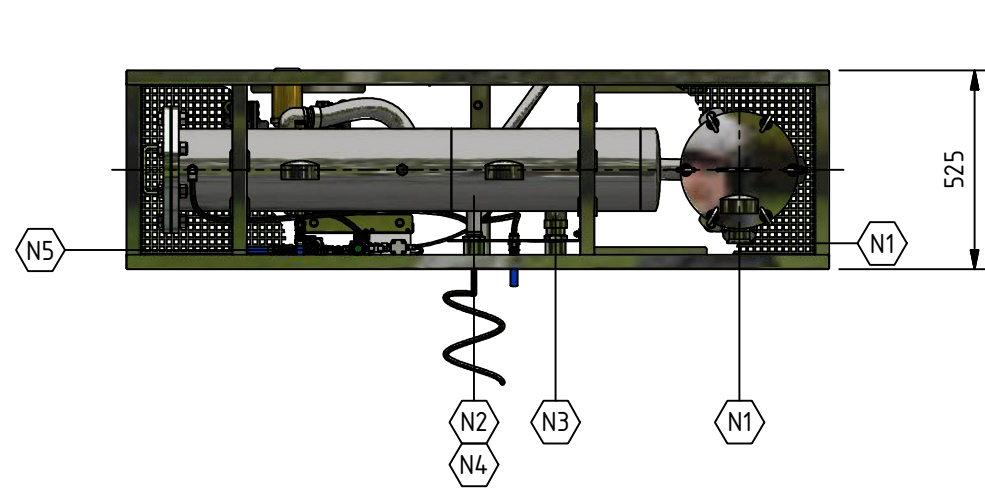

TOP VIEW

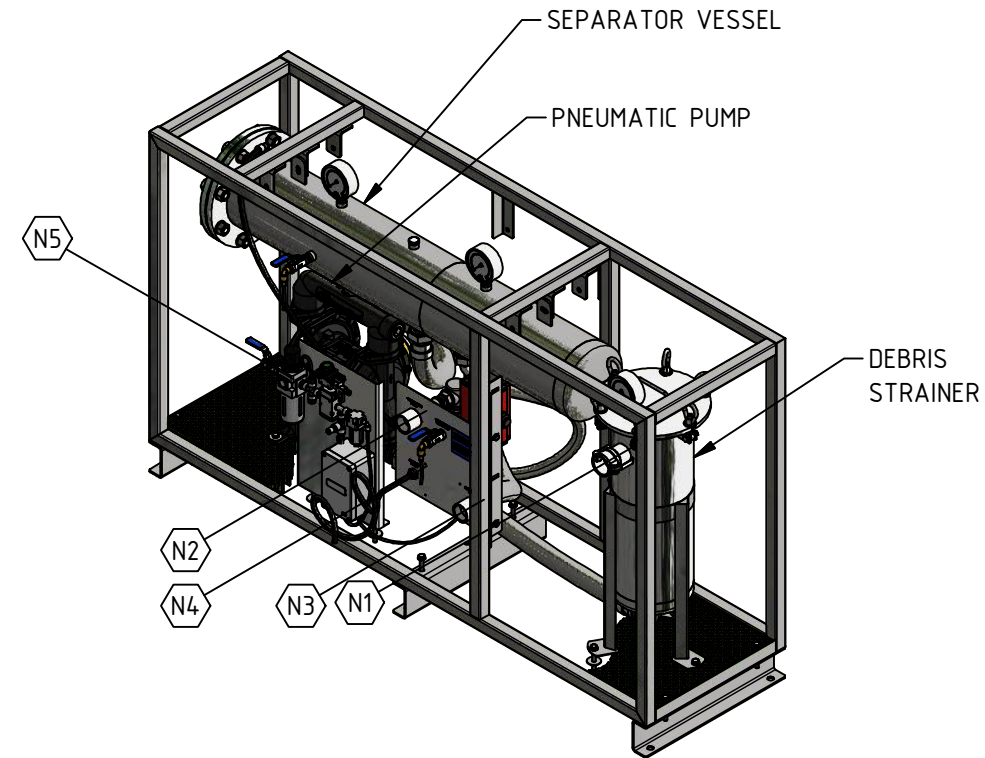

ISOMETRIC VIEW

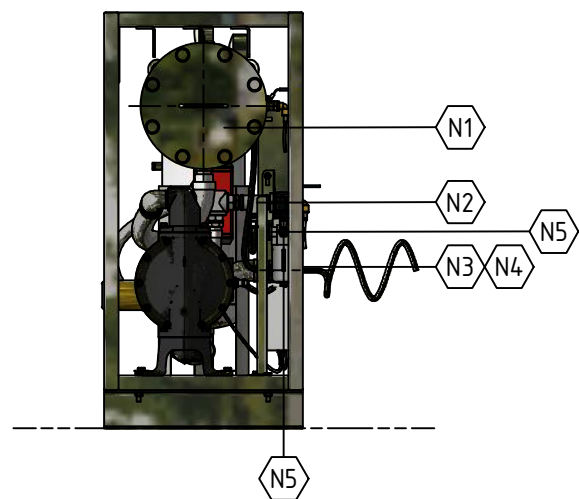

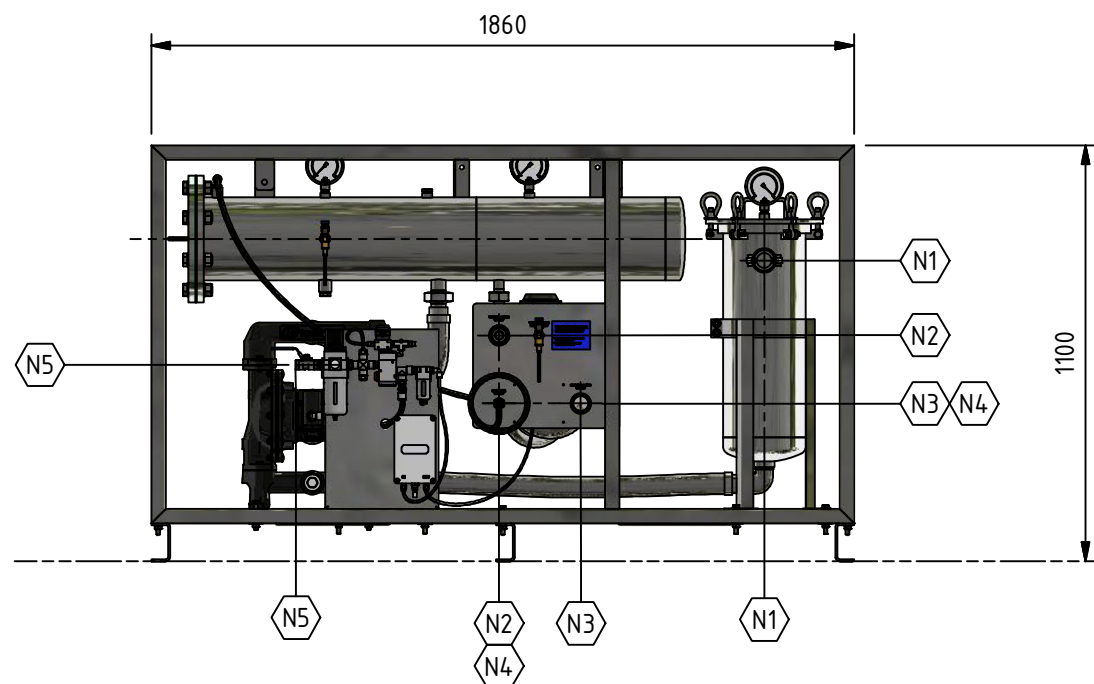

SIDE VIEW

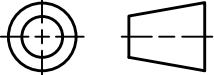

FRONT VIEW

N5	LINE AIR IN
N4	REJECT OIL OUTLET
N3	RECYCLE / DECANT WATER OUTLET
N2	TREATED WATER OUTLET
N1	EFFLUENT INLET
NOZZLE	DESCRIPTION
SITE CONNECTIONS	

REV	DESCRIPTION	DRAWN	CHKD	DATE	DO NOT SCALE IF IN DOUBT - ASK UNLESS OTHERWISE STATED ALL DIMENSIONS IN MILLIMETRES THIRD ANGLE PROJECTION 	 ULTRASPIN PTY LTD 46 WADHURST DRIVE, BORONIA, VIC. 3155 PH: +61 3 8841 7200 www.ultraspin.com.au					CONFIDENTIAL				
A1	ORIGINAL ISSUE	GDS	I.S.	01-Jun-18		CHANGES ON THIS DRAWING MAY BE RECORDED IN TWO PARTS: eg A1, A2 A,B,C: DENOTES A 3D-CAD CHANGE 1,2,3: DENOTES A DRAWING FACE CHG THAT DOESN'T AFFECT THE 3D-CAD	TITLE 7.5m³/hr "EDGE" OILY WATER SEPARATOR MODEL: PB70-AR (PNEUMATIC, AUTO RECYCLE)								
						CLIENT					TYPICAL				
		SCALE	SIZE	DRG No.			SHEET	REV							
		1:20	A3	PB70-AR/SD			1 of 1	A1							

THIS DRAWING IS THE PROPERTY OF ULTRASPIN AND MUST NOT BE USED OR COPIED WITHOUT THEIR WRITTEN PERMISSION. FEATURES OF THE ULTRASPIN PRODUCTS AND PROCESS SHOWN ARE PATENTED OR PATENT PENDING. PROCESS AND EQUIPMENT DESCRIBED SHOULD NOT BE USED WITHOUT PRIOR WRITTEN CONSENT FROM ULTRASPIN TM-TRADE MARK OF ULTRASPIN Pty Ltd