

MASCOT ENGINEERING CROSS FLOW INTERCEPTOR

(Oil/Water/Solid Separator)

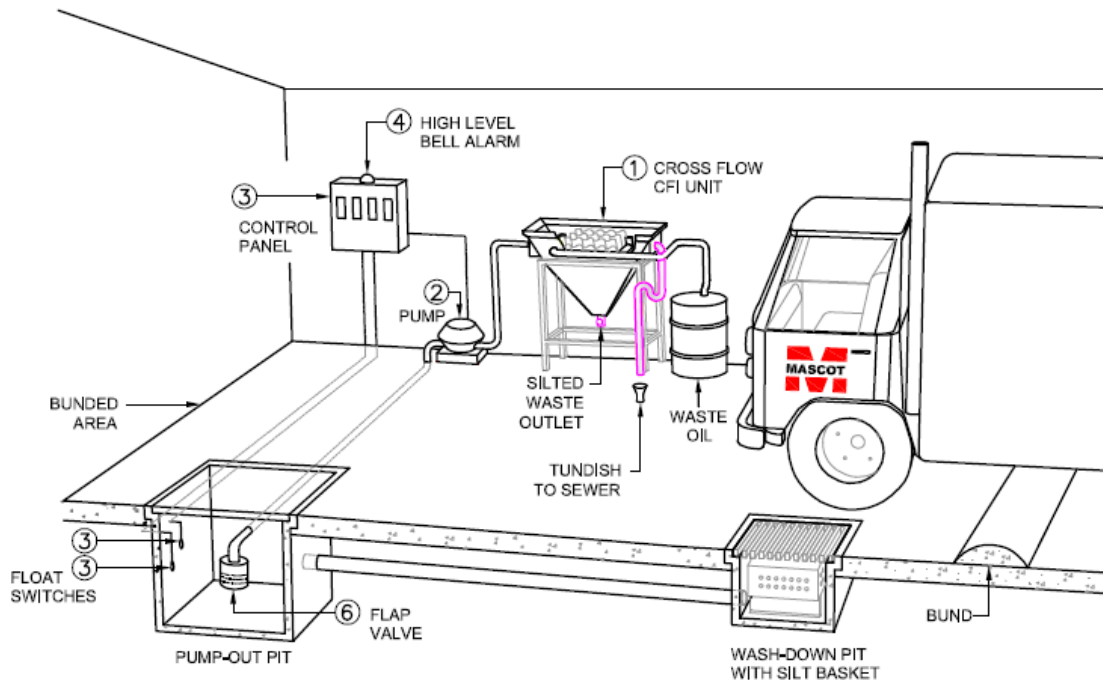

PICTORIAL VIEW OF SETUP

SCALE: NTS

MASCOT CROSS FLOW INTERCEPTOR UNIT

MASCOT ENGINEERING CO PTY LTD
37 Tarlington Place, Smithfield NSW 2164 Australia
Ph: 02 9828 2600 – Fax: 02 9828 2611

ABN: 40 000 215 734

Version TGWA1.02 07/11/2023

Email: sales@mascoteng.com.au

Website: www.mascoteng.com.au

(AUSTRALIAN DESIGNED AND MANUFACTURED)

CROSS FLOW INTERCEPTOR UNIT

After many years of development, Mascot Engineering has produced the most efficient Cross Flow Interceptor Unit on the market today. The unit is a combination of Mascot's Lightweight Glass Reinforced Concrete Tank and 60 degree Plate Pack Unit.

Units can be supplied in 2 standard models (CFI 15) up to 1500 litres per hour and (CFI 30) 3000 litres per hour, capable of reducing the oil content in the effluent to less than 10 parts per million.

Both units are supplied with 1 Float Switch and 6 metres of cable.

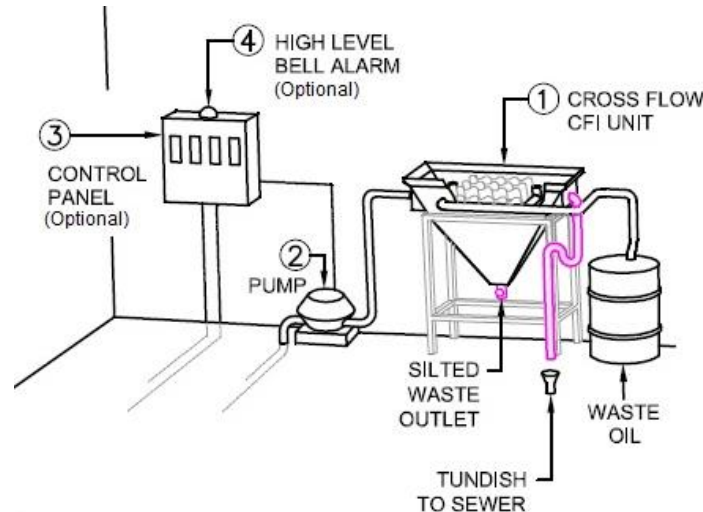

Typical Layout of CFI installation

OPERATION

The oily water and sludge are collected in a wash down pit, here the heavier solids are trapped by way of a stainless steel basket or silt tray, depending on the application. The oil and the remaining solids are then introduced into the Cross Flow Interceptor Unit by a pump system. Oils and solids are removed from the water stream by gravity separation between the multi-plate corrugated pack.

The oil droplets rise in the flow and are caught when they reach the plate above, in the same way solid particles settle on the plate below and are retained. The corrugated plate packs are inclined at 60 degrees to the horizontal, so that the solid particles which have been caught by gravity settlement are discharged from the plate pack into the underflow (sludge) hopper where again the

sides are 60 degrees. The oil collects on the surface where it is skimmed off by the oil skimmers into the waste oil tank.

Pump out pits discharging to the sewer must comply with relevant state water specifications. Mascot Units can be coupled with a range of holding wells for the eventual recovery and Recycling of the clean water if desired.

PERFORMANCE/PUMP SUPPLY

It is important that the oil droplets in the flow be larger than 60 microns, or a proportion of smaller droplets will pass through the unit and effect the effluent quality.

With the correct flow rate, the Mascot Cross Flow Interceptor Unit will deliver an oil content in the effluent of no greater than 10 parts per million, which exceeds the standards for discharge to storm water and sewer systems.

SOLID SEPARATION

If the solids are not continuously discharged from the plates as they settle, they will accumulate and block the plate pack, consequently, removal of such solids from the plates is of critical importance for the continued efficient operation of the separator.

In all Mascot Cross Flow Interceptor Units, the plates and the walls of the hopper are set at 60 degree from the horizontal, which is greater than the angle of the repose of the settled solids, this ensures that the plate pack is self cleaning and when the sludge hopper is opened and all sludge will be removed.

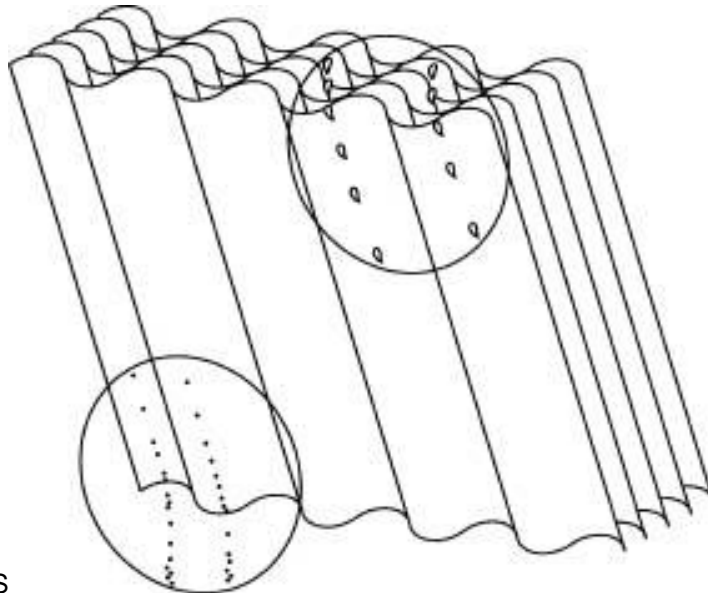

SOLIDS



Cast Iron Gas Tight Covers & Frames – Precast GR Concrete Products – Grates – Drainage Products – Pollution Control & Design

FLOW CAPACITY

Mascot Cross Flow Interceptor Units have a total plate area of 9 square metres, set at 60 degrees to give an effective area of 4.5 square metres, which will intercept all 60 micron droplets at a flow rate of up to 3000 litres per hour.

CFI INFORMATION SHEET

PRODUCT: CFI 1500 Litre and CFI 3000 Litre

- The above mentioned units are sold complete with the following:
- Galvanised 25mm R.H.S. Stand (880mm high x 900mm wide x 540mm deep with 8 x 10mm bolt holes), which can be either floor mounted or wall mounted.
- The CFI Tank – which is GR Concrete, painted externally with grey colour paint and internally with T24 Bituminous Black Epoxy.
- Two adjustable Skimmer Units plus or minus 6mm to suit 40mm PVC pipe.
- One 50mm outlet pipe.
- One 32mm high pressure 'T' for pump inlet.
- Corrugated Plate Pack Unit, angled at 60 degrees with spacing at 10mm. Also supplied is one (1) 4mm stainless steel guide and anchor to correctly position the plate pack. All fittings are 316 Stainless Steel and for ease of removal and replacement there is a stainless steel handle.
- The Sludge Outlet – 50mm Brass Gate Valve.
- Two-part GR Concrete Cover which drops neatly into the top of the unit.
- One Float Switch with a 6 metre cable.
- One Mono Pumps CP25 “Progressive Cavity” type pump. For the CFI15 unit, the flow rate is 1500 litres/hour.
- OR
- One Mono Pumps CP800 “Progressive Cavity” type pump. For the CFI30 unit, the flow rate is 3000 litres/hour.
- Flame-proof motors in both single and 3-phase are available for both CFI units.

CFI INSTALLATION (Western Australia)

MASCOT ENGINEERING CO PTY LTD
37 Tarlington Place, Smithfield NSW 2164 Australia
Ph: 02 9828 2600 – Fax: 02 9828 2611

ABN: 40 000 215 734

Version TGWA1.02 07/11/2023

Email: sales@mascoteng.com.au

Website: www.mascoteng.com.au

To give best results, the CFI must be installed level.

Installation must also take into consideration any specific conditions of relevant water authorities.

To comply with Water Corp Western Australia requirements the inclusion of the following is required:

- a. The Tundish that receives waste from the unit needs to be connected to a trade waste sampling point (TWSP) as per typical drawing [HX33-12-10 for small plate separator](#). Note: The tundish spill level needs to be higher than the bund height.
- b. Extract from drawing HX33-12-10 Shows requirements for Bunding the area around the unit. Note: The Bund must include the Waste catchment of Sludge and Waste Oil in case of leaks. The floor of the banded area is to be drained back to the collection pit.

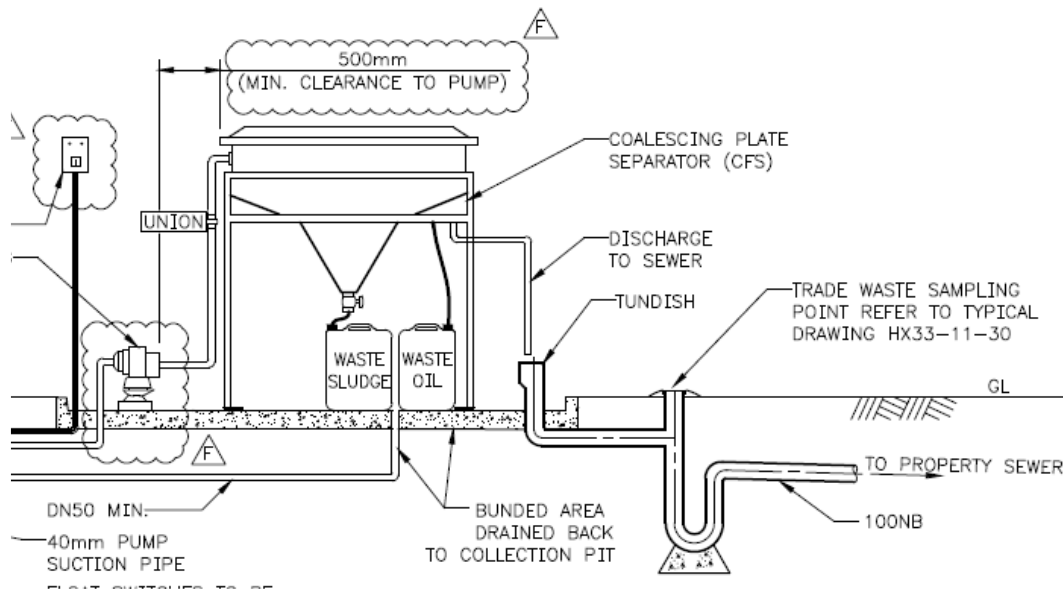

Extract from drawing HX33-12-10

Access covers to collection pits and silt pumps must comply with AS3996: 2019 (Access Covers and Grates)

Use the holes provided in the frame to securely bolt the stand to the wall or floor.

Use minimum grade 12-pressure pipe for pump inlet/discharge lines - DWV for CFI outlet and skimmers.



Cast Iron Gas Tight Covers & Frames – Precast GR Concrete Products – Grates – Drainage Products – Pollution Control & Design

Use of pipes smaller than the port size of the pump will void warranty.

Remember, the float switches come standard with 6 metres of cable. If you need more, let us know at time of quote/order. As per Water Corp Western Australia requirements Float Switches should be secured to the suction line of the collection Pit.

If locating the separator remotely from the area of operation, allow for the fact that the tank will need to be emptied during maintenance. This means it will need ready access and a way of disposing of its contents (not down the drain!).

The pump is unable to process too much solid debris. This especially includes nuts, bolts and washers. If you do not intend to install a basket strainer in the sump pit, at the least you should consider an upturn at the beginning of the pump intake line. This is also helpful in excluding silted particles of which if too much passes into the interceptor, will increase maintenance frequently and yield poorer results.

Attempt to have the pump-out pit, the pump and the separator as close together as possible as the pump delivery rate is greatly affected by the distance of the pipework. More pipework and height of lift will markedly reduce the flow rate.

The two oil skimmers are set at arbitrary levels only, as each unit leaves the factory. The final heights of the skimmers must be set to suit your requirements at time of installation. The threaded collars allow approximate height variation of plus or minus 6mm. Accurate skimmer height is absolutely vital in ensuring that the unit can consistently deliver as best quality discharge water as can be expected in your particular circumstances.

The plate pack is positioned correctly by the use of 4mm stainless steel guide and anchor. This is to ensure the unit's maximum efficiency is achieved. The anchor is designed to ensure that the plate pack is positioned flat against the upstream baffle.

The final weir must be true and level once the CFI is full. Then tighten and fix to the ground.

Installation must also take into consideration any specific conditions of relevant water authorities.

To accurately set skimmer height, the tank needs to be filled with water and the pump operating. Where there are reasonably and constantly low volumes of oil in water, the skimmer height can be set so that just a dribble of liquid spills into the skimmer body (surface tension will pull the oil towards the skimmer thereafter). For more severely contaminated oily water, set the skimmers more "aggressively" (lower).

Keep checking your settings every 5 minutes or so to ensure that you are on the right track and do not forget that as you get close to the optimum, even half a turn will give markedly different results.

Skimmer settings should then be monitored regularly over the first week of operation to ensure ideal results. Thereafter, if the water quality changes either way, a slight adjustment may ensure peak performance.

MASCOT ENGINEERING CO PTY LTD
37 Tarlington Place, Smithfield NSW 2164 Australia
Ph: 02 9828 2600 – Fax: 02 9828 2611

ABN: 40 000 215 734

Version TGWA1.02 07/11/2023

Email: sales@mascoteng.com.au

Website: www.mascoteng.com.au



Cast Iron Gas Tight Covers & Frames – Precast GR Concrete Products – Grates – Drainage Products – Pollution Control & Design

We have provided the information herein as a guide only. Please contact our office if you have any queries on situations or specifics that require more individual attention.

MAINTENANCE

1. All Mascot Cross Flow Interceptor Units are manufactured from Glass Reinforced Concrete and coated internally with a Two Part Epoxy Coating. The plate pack connecting rods and fittings are 316 Stainless Steel, Pipe Fittings are of P.V.C. hence no structural maintenance is required.
2. The discharge of oil from the Unit to the waste oil tank is automatic, again no maintenance is required.
3. The underflow (sludge) Hopper – where the solids settle – should be cleaned at intervals of not more than 3 months. This would be determined by environment and the solids loading on the unit installed.

The plate packs should be removed and thoroughly cleaned, the tank should be cleaned and washed out and the pump and pump lines should be thoroughly flushed. Using the 4mm stainless steel guide and anchor replace and position the plate pack correctly. The plate pack should be sitting flat against the upstream baffle. Then refill the tank with clean water.



Cast Iron Gas Tight Covers & Frames – Precast GR Concrete Products – Grates – Drainage Products – Pollution Control & Design

CLEANING OF CFI UNITS

1. Isolate Pump;
2. Release gate valve to empty CFI unit into a holding tank (for approved disposal);
3. Remove plate pack (do not disassemble) and clean. Collect waste water in holding tank for approved disposal);
4. Clean internal surfaces taking care not to damage the internal coating;
5. Check all internal surfaces for wear and tear. Re-coat if necessary. Contact the Manufacturer for up to date details for re-coating;
6. Close gate valve, replace plate pack (be sure plate pack is correctly seated and refill tank with clean water;
7. Refer to the Operating and Maintenance Instructions for Mono CP Pumps;
8. Waste oil drum to be always connected and disposed of in an approved manner.

(MINIMUM CLEANING FREQUENCY IS 3 MONTHS)