

# Cleartec Coalescing Separator

Installation, operation, and maintenance

June 2023 v4.1





# Cleartec Coalescing Plate Separator

Installation, operation, and maintenance

## Revision History

VER	DATE	DESCRIPTION OF CHANGES	PREPARED	CHECKED	APPROVED
4.1	16/06/2023	ISSUED FOR USE	YF	JD	JD

## Contents

<b>1</b>	<b>Safety</b>	<b>4</b>
1.1	Prior to operation .....	4
1.1.1	Correct wash bay procedures .....	4
1.1.2	Correct maintenance procedures .....	4
1.2	WARNINGS .....	4
<b>2</b>	<b>System description</b>	<b>5</b>
<b>3</b>	<b>Installation</b>	<b>6</b>
3.1	Pipework .....	6
3.2	Installation of level floats .....	8
3.3	Silt arrestors .....	9
3.4	Oil skimmer and water outlet detail .....	9
3.5	Installation of a diaphragm pump .....	10
3.5.1	General .....	10
3.5.2	Electrical .....	10
3.5.3	Gear reducer .....	10
3.5.4	Engine .....	10
<b>4</b>	<b>Operations</b>	<b>11</b>
4.1	Checking the float switches .....	11
4.2	Setting the correct water level .....	11
4.3	Adjusting the oil skimmer .....	11
4.4	Observe and adjust .....	11
<b>5</b>	<b>Maintenance</b>	<b>12</b>
5.1	Cleaning frequency .....	12
5.2	Daily maintenance .....	12
5.3	Weekly maintenance .....	12
5.4	Quarterly maintenance .....	12
5.5	How to clean separator .....	13
5.6	Protection .....	13
5.7	Diaphragm pump maintenance .....	14
5.8	Replacement of diaphragm .....	15
5.9	Replacement of flap valves .....	15
<b>6</b>	<b>Warranty</b>	<b>16</b>
	Appendix A .....	17
	Appendix B .....	19
	Appendix C .....	21

## 1 Safety

---

### 1.1 Prior to operation

Thank you for choosing the Cleartec System to handle your trade waste requirements.

We are confident that the system will deliver several years of service without issues. However, the longevity and efficiency of the system is dependent on the following two points, and on those detailed in this manual. Please familiarise yourself with them prior to operation.

#### 1.1.1 Correct wash bay procedures

Gravity-based separation systems cannot operate efficiently with degreasers. It is mandatory that degreasers are not used in wash-off bay this separator is treating; a quick break biodegradable detergent must be used.

#### 1.1.2 Correct maintenance procedures

The on-going effectiveness of the system is dependent on regular maintenance (as detailed in this manual) being carried out. Due to the importance of this procedure, we strongly recommend you establish a service contract with Allied Pumps Service Division to ensure this is performed properly and according to the schedule.

### 1.2 WARNINGS

- Under no circumstance must traces of acetone or thinners pass through this separator.
- Only allow qualified personnel to install, connect, and operate separator pump, motor, and switchgear.
- This separator is designed to separate oil and water and must not be used for any other purpose.
- This separator is not designed to handle liquids below a pH of 2 or above a pH of 12.
- Liquids outside of this range shall not be allowed to pass through the separator, otherwise serious consequences could result.
- Adequate lifting and moving equipment shall be used to prevent injuries to personnel or damage to equipment.
- All pipe and connections shall be verified to be tight, properly supported, and secure before operation post installation of the separator.
- For your safety, read all relevant instruction manuals prior to connecting or operating equipment, refer to engineer's department and wear appropriate personal protective equipment.

## 2 System description

The Cleartec Coalescing Plate Separator (CPS) is an enhanced, gravity separator incorporating the latest technology.

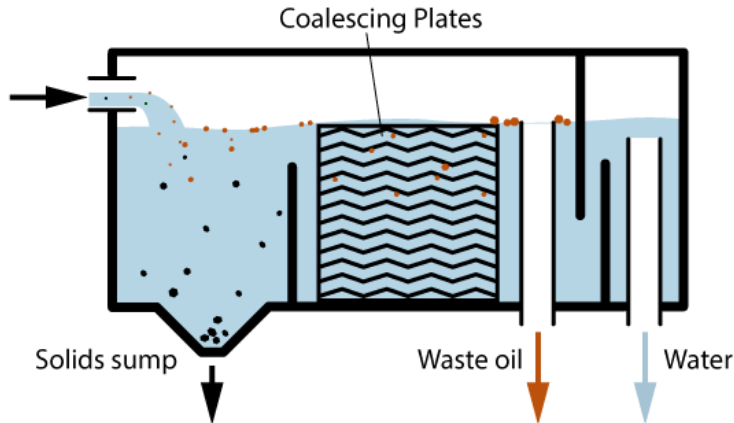

*Fig. 1 CPS basic operation*

CPS units are designed with a combination of vertical and horizontal coalescing plates. From the inlet port the flow is directed through the vertically-orientated plates where solids are separated under gravity for collection in the hopper below. The horizontally-orientated plates remove oil droplets by coalescing them to form larger oil particles, thereby increasing their rising velocity and capture rate.

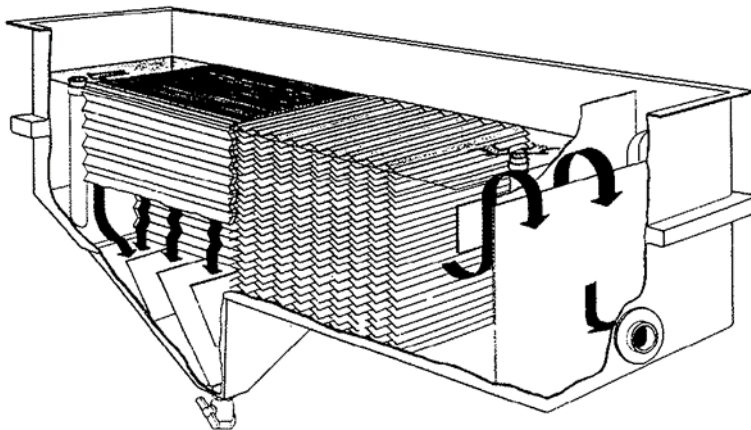

*Fig. 2 CPS plates illustration*

## 3 Installation

Position the CPS as close as possible to the waste collection pit that the separator pump is drawing from.

The CPS should be mounted on a level, reinforced concrete plinth/slab of adequate thickness to take the weight of the unit. In the case of a wall mounted unit, a structurally sound wall capable of supporting the weight of the unit when full of liquid.

If the CPS is to be installed in a trafficable area, suitable protection bollards should be installed accordingly. It is extremely important that the CPS be mounted level to horizontal within tolerance of  $\pm 2.5$  mm to facilitate successful operation. Packing under one or more of the legs may be necessary for the final levelling of the unit. The Separator should be fastened to the plinth with 10 mm sleeve anchor type bolts, one bolt per leg, through the pre-drilled holes.

### 3.1 Pipework

Correct pipe size is a critical factor affecting pump performance and service life. Refer to pipe selection chart below. Fit a suction strainer with apertures no more than 25% of pump port size and a minimum clear area 4 (four) times the port size. Pipe work should be airtight, adequately supported, and be as short and direct as possible. Use flexible connectors between pump and rigid pipe work. Fit a pulsation dampener when a pump is installed with rigid pipe work over 5 m in length. For flexible installations, use reinforced suction hose on both suction and discharge sides. Do not use lay flat type hose.

**Table 1. Pipe selection**

		Suction pipe length		Discharge pipe length		
		0–5 m	5–10 m**	0–5 m	5–10 m	10–20 m
Separator Model	Pump Size	Minimum Internal Dimensions*		Minimum Internal Dimensions*		
KCPS 15FS	DS-25	40 mm	50 mm	40 mm	40 mm	40 mm
KCPS 30FS	DS-25	40 mm	50 mm	40 mm	40 mm	40 mm
KCPS 30FS	DS-32	50 mm	65 mm	40 mm	50 mm	50 mm
KCPS 60FS	DS-38	65 mm	80 mm	50 mm	65 mm	65 mm
KCPS 75FS	DS-50	80 mm	100 mm	65 mm	80 mm	80 mm
KCPS 150FS	DS-76	100 mm	150 mm	80 mm	100 mm	100 mm
<i>Note: use of pipes smaller than recommended will void warranty</i>						

\* For clean liquids with same viscosity as water \*\* Maximum suction pipe length 10 m

Pump suction pipework should be in accordance with the following:

- 1 Suction line from pit to pump must be as direct as possible with the minimum number of bends.  
**WARNING** *The suction line must be fitted with the supplied strainer to prevent blockages. Failure to do so could damage pump.*
- 2 The suction line should not touch the bottom of the pit. Leave a gap of 10 mm to safeguard against sludge or other sedimentation entering the pipeline, causing blockages and damage to pump.
- 3 Cleaning of this pit should be carried out regularly as discussed in the maintenance section of this manual.
- 4 The suction line from the pit to the pump and from the pump to the separator must be free of air leaks.
- 5 Suction and discharge pipework should be supported by stand-off brackets or saddles at regular intervals to provide adequate support.
- 6 In the case of discharge to sewer the pipeline should have a continuous fall.
- 7 In situations where a fall to sewer is unable to be obtained (or not practical) a pit must be installed nearby to receive the discharged effluent from the separator. The effluent can then be discharged to sewer by means of an automatic, submersible pump. In these installations PVC pressure pipe should be used and discharged over a suitable industrial waste discharge point.
- 8 Entry to sewer must be via Water Corporation standard design industrial waste discharge point as illustrated in *Fig. 3*.
- 9 If the discharge line from the separator is longer than 6 (six) metres a suitable vent and cowl must be installed.
- 10 In the case of sewage pipelines longer than 6 (six) metres: expansion joints must be used at regular intervals as specified by local trade practise requirements.
- 11 It is recommended that a union is installed on suction and discharge of pump to allow ease of disconnection for service and maintenance.
- 12 The suction line from the pit to the pump and from the pump to the separator must be free of air leaks.
- 13 Suction and discharge pipework should be supported by stand-off brackets or saddles at regular intervals to provide adequate support.

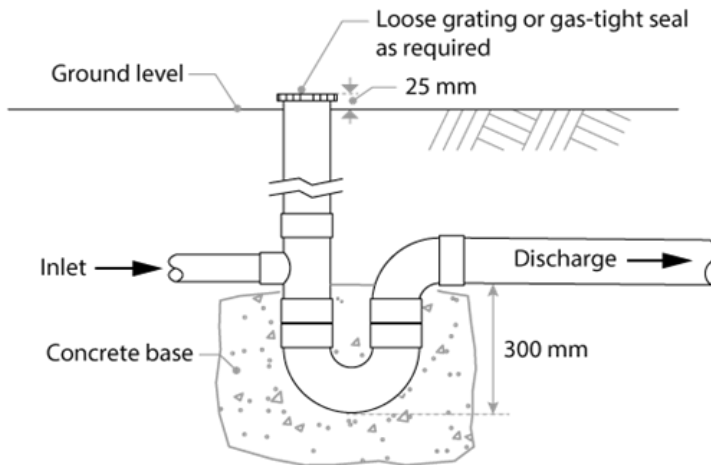

*Fig. 3 Water Corporation Standard Design Industrial waste discharge point.*

## 3.2 Installation of level floats

- 1 Float Switches, fitted with cable-weights, are supplied. They should be hung from a tethering point near the top of the chamber.
- 2 The pump start/stop float switch should hang approx. 200 mm above the bottom of the pump suction strainer. If the float switch is not higher than the suction point, the pump will suck air and will not turn off automatically.
- 3 The high-level alarm float switch should be hung approximately 150 mm below the invert of the inlet pipe. This may vary in larger tanks.
- 4 Ensure floats are free from obstruction and can move up and down freely.



### 3.3 Silt arrestors

While Cleartec separators can accommodate a nominal amount of sludge, when heavy solids, cloth or excessive silt is expected, provision should be made for accommodating them in the sump. The most economical method of achieving this is with a basket silt arrestor. It is advised that every installation incorporates a silt arrestor to minimise potential damage to pump and the separator. Refer to Fig 4. For typical installation.

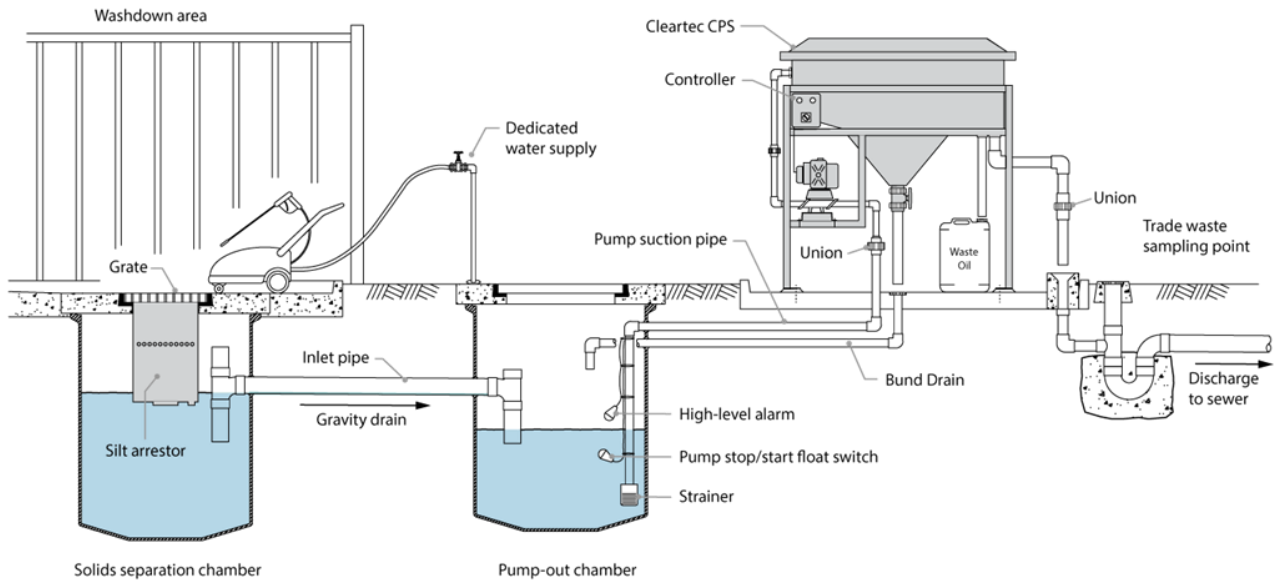

Fig.4 Cps Common installation diagram

### 3.4 Oil skimmer and water outlet detail

Ensure oil skimmer is set when pump is operating; oil skimmer is to be set approximately 5 mm above water level as shown in Fig. 5.

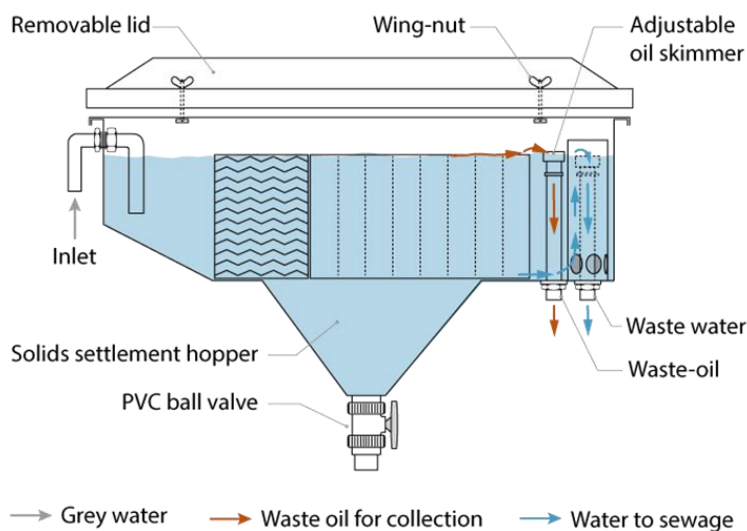

Fig. 5 Elements in a CPS

Note: This diagram is for illustrative purposes only. It does not apply to a particular model.

## 3.5 Installation of a diaphragm pump

### 3.5.1 General

Install the pump level and secure using holes in baseplate.

### 3.5.2 Electrical

Wire electric motors to manufacturer's instructions, usually on the motor nameplate or junction box. Most 240 VAC motors have built in overload protection; all other motors require overload protection wired into the circuit.

- Ensure there is unobstructed airflow to the motor cooling fan.
- Protect motors from weather and water.

**WARNING** Check motor rotation. Correct motor rotation is clockwise viewed from the fan end. Incorrect rotation will damage the pump and void warranty.

### 3.5.3 Gear reducer

- Remove vent plug from oil filler cap.
- Check oil is visible in sight glass before starting up.
- Recommended oil: Shell Omala 320 Castrol Alpha SP320.

### 3.5.4 Engine

- Fill engine with correct grade oil before operation. (Specified in engine owner's manual)
- Do not operate engine without adequate ventilation.
- Check oil level regularly.
- Maximum pump speed should not exceed 48 strokes per minute.

## 4 Operations

Before starting up, make certain that the separator is firmly anchored to the plinth and that all pipework and connections are secure and properly supported.

The pump and suction line should be primed before starting for the first time.

### 4.1 Checking the float switches

Turn the selector switch in the control panel to Automatic. Check that the sequence of the level floats is correct. This is done by lifting each level float by hand. The pump should be activated upon the rise of the lowest float. The top float should activate the redlight signal and when both floats are let down, the pump should turn off.



Fig. 6 Control panel

### 4.2 Setting the correct water level

Allow the separator to commence operating. The water level should rise to just above the plates. If it rises higher or lower than this level, the expansion coupling on the water outlet standpipe should be pushed down or pulled up until the water level is just above the plates (approx. 5 mm).

### 4.3 Adjusting the oil skimmer

The operating water level rises and falls in accordance with the hydraulic action of the pump; skimmer should be set 5 mm above the highest rise level. This is an expansion PVC coupling and is adjusted by moving the inner sleeve up and down.



Fig. 7 Oil Skimmer

### 4.4 Observe and adjust.

Inspect the liquid flowing through the plates and towards the outlets. Check that no water is passing over the oil skimmer and if so, adjust accordingly.

- Check the effluent is flowing into sewer gully without splashing.
- Check the oil waste drum is situated under the waste-oil outlet so there is no spillage.

## 5 Maintenance

---

### 5.1 Cleaning frequency

The most suitable period between maintenance is dependent upon the quality of the influent the separator is to treat. It is recommended that initially, maintenance as described below, be performed and adjusted if necessary to meet the quantity of sludge in the system.

### 5.2 Daily maintenance

- Remove any obstruction from the grates of the pit and drains.
- Visually inspect the system for any leakages. If any detected, report to the Maintenance Manager.
- Visually inspect the control panel. If the panel is not operational, report to the Maintenance Manager.
- Visually inspect the discharge effluent. If the effluent is not typical of normal discharge, take a sample and record the time and details of the previous work on the wash-bay including the type of detergent used.
- Check that the pump is operational.

### 5.3 Weekly maintenance

- Same procedure as for the daily maintenance is to be followed.
- Remove the lid from the separator and remove any floating and solid matter.
- Thoroughly wash down the wash-bay.
- Check the gear oil level in the reduction gear box.
- Check the levels in the waste oil drum and arrange for disposal if required.
- Check the level of the sludge in the pit and arrange for disposal if required.

### 5.4 Quarterly maintenance

- Same procedure as for the weekly maintenance is to be followed.
- Visually inspect the pit to ensure that the float switches are unobstructed and move up and down freely.
- Clean the separator as per the detailed instructions following.
- Clean out the collection pit.

## 5.5 How to clean separator

- Disconnect the power supply to ensure that the pump remains inoperative for the entire cleaning procedure.
- Remove the lid of the separator.
- Lower the oil skimmer to remove all the oil from the water surface.
- Drain the separator by opening the sludge valves at the bottom of the solids hoppers.
- Remove nyloc nuts from side of separator and remove all stainless-steel hardware holding plate packs.
- Remove plate packs by lifting with the handle provided.
- Inspect and remove any large items that have not drained through the valve.
- Hose down the interior of the tank.
- Hose through the plate stacks with high-pressure water. Do not dismantle the stacks.
- Re-install the plate packs to their original positions.
- Refill the separator with potable water and restart the system.
- Reset the oil skimmer to the original position of approximately 5 mm above the operating water level.
- Check that the unions are tight and that there are no leaks.
- Replace the lid and secure it with wing nuts.

## 5.6 Protection

Allied Pumps recommends protecting this equipment from direct weather and sunlight; equipment should also be protected from direct jets of water from any wash down equipment.



## 5.8 Replacement of diaphragm

- 1 Disconnect power at supply.
- 2 Remove all four casing bolts.
- 3 Lift drive support housing (No. 12) complete with motor and gearbox (No. 13) to one side.  
**Note:** take care to avoid damage to electrical connection
- 4 With access now available to diaphragm (No. 3), remove lower nut (No. 9), washer (No. 10), and diaphragm plate (No. 2).
- 5 Note: stay in original position
- 6 Remove and replace diaphragm (No. 3) with writing on new diaphragm (No. 3) facing upwards. Refit lower diaphragm plate (No. 2), making sure the inner lip edge on the diaphragm (No. 3) is in the corresponding grooves in the diaphragm plate (No. 2). Then re-fit lower washer (No. 10) and nut (No. 9) and tighten.
- 7 Reposition drive support housing (No. 12) onto (No. 1) and locate outer lip edge of diaphragm in corresponding grooves in bowl and drive support housing.
- 8 Re-fit all four casing bolts and tighten evenly. Note: do not over-tighten these bolts
- 9 Re-connect power supply and check operation.

## 5.9 Replacement of flap valves

Before attempting to replace the flap valves, it should be noted that the flap valve assemblies (No. 7) for the suction and discharge ports are identical. Assembly order should be as per diagram (No. 2). When the flap valve assembly (No. 7) is fitted to the suction of the pump, the flap valve assembly will be adjacent to the pump casing (No. 1). However, when flap valve assembly (No. 7) is fitted to the discharge of the pump, the flap valve will be adjacent to the discharge chamber (No. 5).

- 1 Disconnect power at supply.
- 2 Disconnect pipework adjacent to faulty flap valve and corresponding chamber bolts.
- 3 Remove valve chamber (No. 4, 5).
- 4 Remove flap valve (No. 7) and check components for wear and replace accordingly.
- 5 Re-assemble flap valve assembly (No. 7) as per diagram (No. 2).  
**Note:** do not overtighten screw to avoid distortion of flap valve
- 6 Re-fit valve assembly (No. 7) and check flow directions. Suction valve should push into pump whilst discharge valve should lift up and both flap valves should re-seal automatically.
- 7 Re-fit corresponding valve chamber (No. 4, 5) and chamber bolts and tighten evenly.
- 8 Reconnect pipework to valve chamber (No. 4, 5)
- 9 Reconnect power supply and check operation.

## 6 Warranty

---

Warranty is subject to Allied Pumps Pty Ltd terms and conditions of sale and limited to replacement or repair, at Manufacturer's discretion, of any parts or equipment, excluding and travel, site, removal or reinstallation costs, for a period of twelve months from date of invoice, provided such part of equipment is deemed by the respective manufacturer to be faulty. Any work done on site to inspect or remedy faults that are subsequently not accepted as being under warranty by the manufacturer (e.g. caused by misuse, fair wear or operating procedures) will be charged at rates applicable at the time including parts, labour and travelling time.

Warranty does not provide for circumstances outside Allied Pumps' control including, but not limited to, seismic activity, base or ground movement, mechanical impact, abuse or negligence, or general wear and tear.

Warranty does not cover equipment that is not installed, continuously monitored, and maintained in accordance with the manufacturer's requirements, including, but not limited to, regular servicing, and/or regulatory requirements and applicable Australian Standards. Warranty does not cover damage caused by dry running the pumps.

If Buyer requires our services in respect of site inspection or service outside of what is covered by Manufacturers' warranties, then Buyer should enter into a separate agreement with Allied Pumps in respect to the same. In the event of no such separate agreement, all operations, calibrating, cleaning, and maintenance of plant is the responsibility of the buyer.

Allied Pumps have not acted as a consultant nor charged design fees on this project, and are in no way responsible for, nor guarantee any particular level or performance of the treatment plant supplied or effluent quality unless such guarantee is specially given in writing. Under no circumstances is Allied Pumps liable for any direct or consequential loss or business interruption or damage to persons or properties of any nature due to any cause whatsoever.

Application of warranties is conditional on Allied Pumps having received in cash the total contract price. Furthermore, Allied Pumps reserves the right to withdraw any code compliance, Australian Standard compliance or selection compliance, should the contract not be paid in full.



## Appendix A

---

### Quickbreak detergent MSDS



enviropius

# e-GreenKleen

QUICKBREAK COCONUT BASED DETERGENT  
NATURAL HIGH POWER MACHINERY WASH

e-GreenKleen heavy duty degreaser is a quickbreak and biodegradable plant derived concentrate for light to heavy soiled and greased surfaces. e-GreenKleen can be applied as neat by spray or brush or can be diluted with water and used through pump or water blaster.

- » Quick Break Formula
- » Non-toxic Naturally safe - phosphate free
- » Eco friendly plant derived surfactants
- » Non caustic non flammable
- » Suitable for use in oil separators & recycle systems



CAUTION: KEEP OUT OF REACH OF CHILDREN, IF SWALLOWED SEEK MEDICAL ADVICE

ACTIVE INGREDIENTS



BIO-DEGRADABLE



INDUSTRIAL STRENGTH



PLANT BASED



## APPLICATIONS

Ideally suited for use in all automotive and Industrial applications requiring a heavy duty green safe all purpose cleaner. Can be used for removal of all oil and grease residues on floors, walls, vehicles, locomotives, stationary engines, compressors, & trucks etc.

mining commercial domestic

## DIRECTIONS FOR USE

**Heavy Duty Degreasing:** 1:10 parts water

**Medium Cleaning:** 1:50 parts water

**Light Cleaning:** 1:100 parts water

## STORAGE

Store in cool area away from direct sunlight.

## EMERGENCY FIRST AID PROCEDURES

**SPILL:** Contain excess material and wash area to dilute.

**SKIN:** Remove contaminated clothing and footwear. Wash solution off skin with plenty of water and soap and seek medical attention. Wash clothing and footwear before continued use.

**EYES:** Immediately flush with water for at least 15 minutes and have eyes examined by medical personnel.

**INGESTION:** Drink plenty of water or milk to dilute. DO NOT induce vomiting, seek immediate medical attention.

Made in Australia

Distributed by Abco Products Pty Ltd.

44 John St  
Bentley WA 6102

Tel 1800 177 399

Email [sales@abcopro.com.au](mailto:sales@abcopro.com.au)

[abcopro.com.au](http://abcopro.com.au)

be planet positive

## Appendix B

---

### General Arrangement (typical layout)

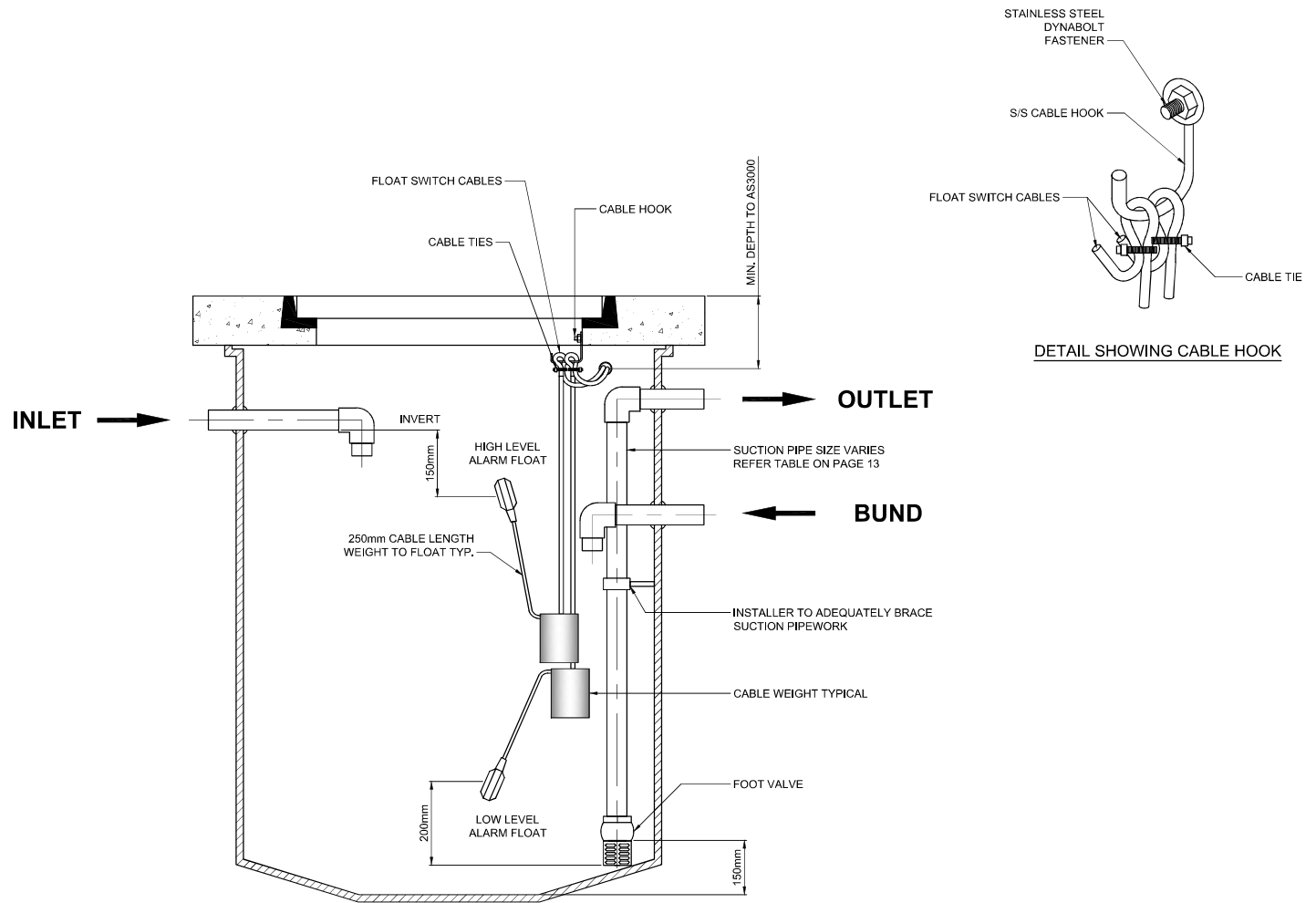

REV	DESCRIPTION	BY	DATE	CHK	DATE	APP	DATE	REFERENCE
B	ADDED RETURN LINE BACK TO PIT							
A	ISSUED FOR APPROVAL	CLP	13.03.17	LAS	13.03.17	LAS	13.03.17	

**Specialists in Package Pumping Solutions**

**AP Allied Pumps**

2 Modall Crescent (Cnr Baile Rd)  
Canning Vale, WA 6155  
+61 (08) 9350 1000  
www.alliedpumps.com.au

COPYRIGHT. THIS DRAWING AND DESIGN MUST NOT BE COPIED IN WHOLE OR IN PART WITHOUT THE WRITTEN CONSENT OF ALLIED PUMPS AND AS REPRODUCED MUST CARRY ALLIED PUMPS DESIGNATION.

CLIENT:	ALLIED PUMPS	TITLE:	PUMP OUT CHAMBER SUCTION AND LEVEL REGULATOR INSTALLATION DETAIL
PROJECT:	DRAFTED ORIGINAL FACTORY SHOP DRAWING	INTERNAL DOC CONTROL:	
SHEET SIZE:	A1	SCALE:	NTS
PROJECT ORG. No.	APBGHP-01	REVISION:	B

TYPICAL NON-HAZARDOUS INSTALLATION - REFER AS/NZS 60079.10.1:2009

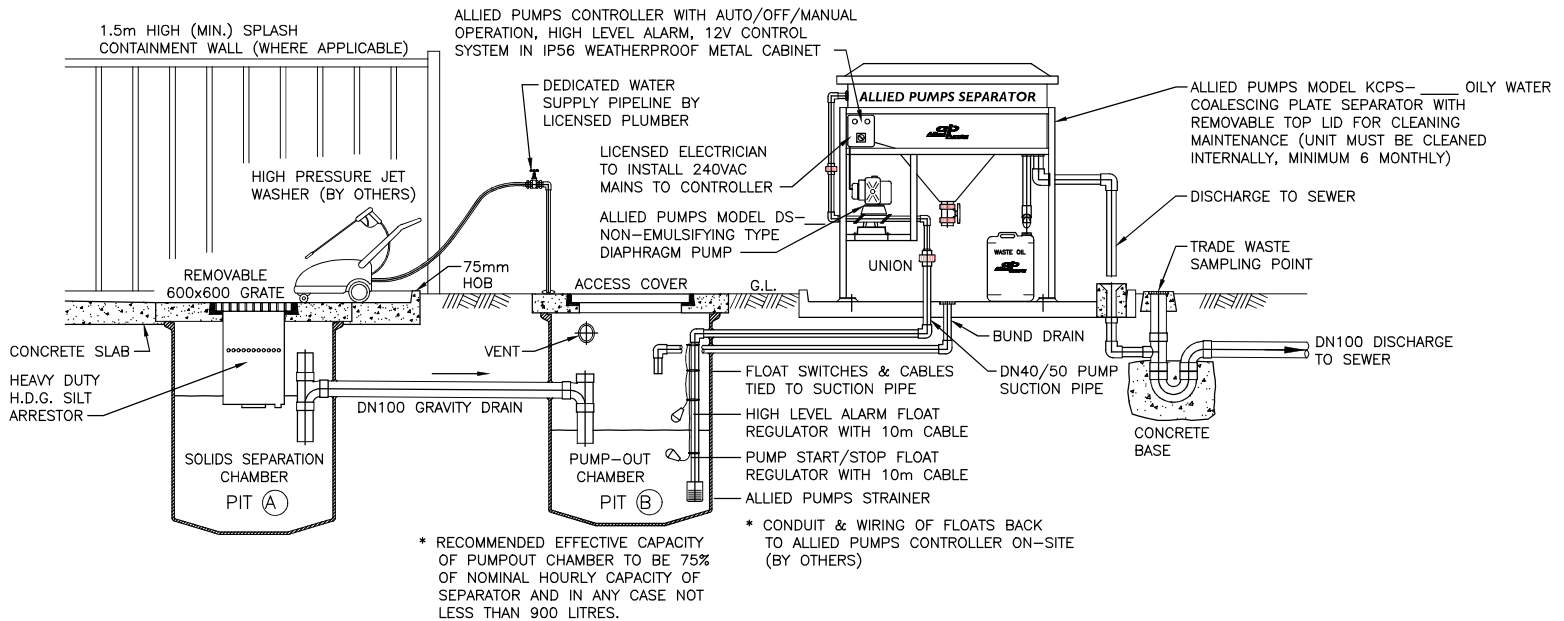

\* RECOMMENDED EFFECTIVE CAPACITY OF PUMPOUT CHAMBER TO BE 75% OF NOMINAL HOURLY CAPACITY OF SEPARATOR AND IN ANY CASE NOT LESS THAN 900 LITRES.

\* CONDUIT & WIRING OF FLOATS BACK TO ALLIED PUMPS CONTROLLER ON-SITE (BY OTHERS)

SECTION 1

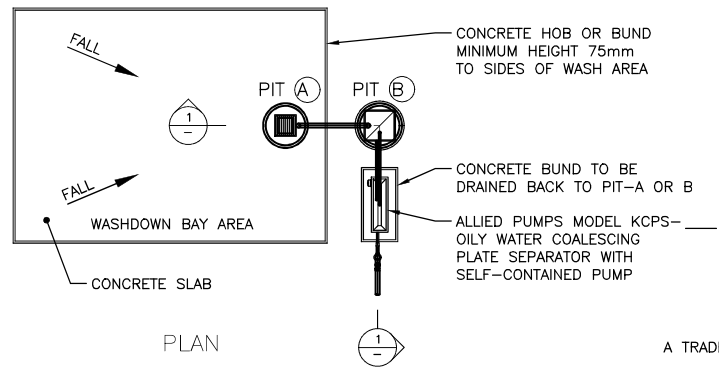

- ITEMS OF EQUIPMENT IN PACKAGE
- (A) ALLIED PUMPS COALESCING PLATE SEPARATOR KCPS- \_\_\_\_ WITH HOT DIP GALVANISED FRAME.
  - (B) ALLIED PUMPS DIAPHRAGM PUMP DS- \_\_\_\_ MOUNTED AND PRE-PLUMBED TO SEPARATOR AND PRE-WIRED TO CONTROLLER.
  - (C) ALLIED PUMPS CONTROL PANEL & 2 FLOAT REGULATORS.
  - (D) WASTE OIL DRUM.
  - (E) ALLIED PUMPS SUCTION STRAINER.
  - (F) OPERATION & MAINTENANCE MANUAL.

- INSTALLATION DETAIL
- (A) WASH BAY SIZE: \_\_\_\_
  - (B) PIT-A SIZE: \_\_\_\_
  - (C) PIT-B SIZE: \_\_\_\_

- EQUIPMENT SIZING
- (A) SEPARATOR MODEL KCPS- \_\_\_\_ FS
  - (B) NOMINAL FLOWRATE- \_\_\_\_ L/hr
  - (C) PUMP MODEL DS- \_\_\_\_

TYPICAL SCHEMATIC LAYOUT ONLY

A TRADE WASTE APPLICATION MUST BE SUBMITTED TO WATER CORPORATION PRIOR TO COMMENCEMENT OF INSTALLATION

REV	DESCRIPTION	BY	DATE	CHK	DATE	APP	DATE	REFERENCE
D	TUN-DISH RELOCATED INSIDE THE BUND	MBC	05.07.18	TS	05.07.18	LAS	05.07.18	
C	PROVISION OF TUN-DISH ON DISCHARGE	MBC	14.06.18	TS	14.06.18	LAS	14.06.18	
B	NEW TEMPLATE ADDED	CLP	02.10.14	LAS	02.10.14	LAS	02.10.14	
A	INITIAL DRAFTING & ANNOTATION	PJJ	01.06.04	JWS	01.06.04	GJS	01.06.04	

**Specialists in Package Pumping Solutions**

2 Modal Crescent (Cnr Baile Rd)  
Canning Vale, WA 6155  
+61 (08) 9350 1000  
www.alliedpumps.com.au

COPYRIGHT. THIS DRAWING AND DESIGN MUST NOT BE COPIED IN WHOLE OR IN PART WITHOUT THE WRITTEN CONSENT OF ALLIED PUMPS AND AS REPRODUCED MUST CARRY ALLIED PUMPS DESIGNATION.

CLIENT:	ALLIED PUMPS
PROJECT:	DRAFTED ORIGINAL FACTORY DRAWING
SHEET SIZE:	A1
SCALE:	NTS

TITLE:	ALLIED PUMPS COALESCING PLATE OILY WATER SEPARATOR SYSTEM
GENERAL ARRANGEMENT	
INTERNAL DDC CONTROL:	XXXX
PROJECT Dwg No:	D KCPS-15FS-OWS-01
REVISION:	D



## Appendix C

---

### Maintenance records







[alliedpumps.com.au](http://alliedpumps.com.au)