



SIOS030
Operating Manual
Rev2

CONTENTS

SIOS30 <ul style="list-style-type: none"> • Contents & Contact Details • Warranty Information • SIOS 30 Operating Manual 	
Specific Equipment <ul style="list-style-type: none"> • ASM Pump Manual • OWS Manual • Service Checklists 	
Design Diagrams & Drawings <ul style="list-style-type: none"> • System Layout • Electrical Drawings • Pump Data Sheet 	

Emergency Contact Details

Office hours:
 8am to 4pm (EST) Monday – Friday
 Phone: +61 7 5535 9000
 PO Box 6664 GCMC, QLD

After hours:
 Chemical Related: Refer to MSDS
 Other Phone: +61 426 260 445



EC-W-001
2020 Limited Warranty

Date: 08/04/2020

Revision: 3



Warranty Information

Enviroconcepts International Pty Ltd – Limited Warranty (2020)

Our goods come with guarantees that cannot be excluded under the Australian Consumer Law.

1. What does this warranty cover?

Enviroconcepts International Pty Ltd warrants that its products are free from defects. This is subject to normal use, correct installation, reasonable maintenance and the exclusions set out in this warranty.

2. How long does this warranty last?

This warranty begins at the date of shipment.

The Warranty for any Structural Components including washpads, gutters, gantries, walkways, patios, roofs, skids, walls, ramps, tracked wear plates, gutter lids and specialised product stands (containers & pipes for example) is valid for 5 years.

The Warranty for Parts & Components including pipes, pumps, hoses, motors, chains, tanks, filters, electrical components and floats is valid for 1 year.

Consumables are generally not included in the warranty.

3. What will Enviroconcepts International do if there is a defect?

You must notify us immediately if there is a defect of any kind.

In time critical situations, you may be required to carry out the repairs at your cost, then allow us to inspect the defective product to determine warranty.

Subject to the exclusions set out below, Enviroconcepts International will cover the cost of repairs (by any means at its sole discretion), replace or re-install any defective part or portion of the product which it deems is covered under this warranty.

4. What is required of me to maintain a Valid Warranty?

Subject to these terms and conditions you are required to maintain the following to ensure a Valid Warranty;

Normal maintenance servicing by authorised repairers including (but not limited to): Media changes, motor and pump services, general system and filter cleaning, regular clearing of settled solids and debris from all gutters and catchment areas.

Proof of these services may be requested.

5. What is not covered by this Warranty?

5.1: Enviroconcepts International's liability under this warranty is limited to the cost of repairing, replacing or re-installing any defective part or portion of its product. Enviroconcepts International will not provide any other form of compensation or be liable to pay any other costs associated with any ancillary damage.

5.2: Enviroconcepts International is not liable for, and this warranty does not cover (subject to the provisions of the Australian Consumer Law);

5.2.1: Failure caused by, contributed in whole or in part by, or resulting from any of:

- a) Abuse, such as, without limitation, vandalism;
- b) The introduction of any chemical that would not be permitted in household sewer and not previously approved by Enviroconcepts International
- c) Temperatures greater than the domestic hot water standard both during operation and storage;
- d) Natural disasters or causes, such as flooding, storm, lightning, cyclone or earthquakes;
- e) Attachments to or modifications of the product not authorised in writing by Enviroconcepts International;
- f) External causes, where external, physical or chemical qualities produce damage to the product, its parts or portions such as, without limitation to, unsuitable or hostile environment including the use of a flame or torch or excessive maltreatment including damage or deformation to plastic parts due to extended exposure to direct sunlight; and/or;
- g) Another cause beyond Enviroconcepts International's control including other stresses placed on the product or its contents that are not considered normal to the original intended use or function of the product.

5.2.2: Any economic loss or damage for any consequential or indirect economic loss or damage caused directly or indirectly by our products.

5.2.3 Any injury, loss or damage to persons, property arising out of or in any way as a consequence of the installed product, including any incidental loss or damage to persons or property, loss of use, inconvenience or other incidental or consequential costs.

5.2.4 Any expense not authorised in writing by Enviroconcepts International prior to incurring said expense.

5.2.5 Damage attributed to any of the following:

- a) During shipment, transportation or delivery of the product.
- b) Normal wear and tear of any items including (but not limited to) oil and fuel filters, nozzles, guns, wands, quick connects, O-rings, seals, packing, valve or valve assemblies, water filters, laterals, cartridges, belts, brushes, discharge hoses oil skimming belts, blades, filter media, ozone bulbs etc.
- c) Inadequate electricity, water, venting or fuel supplies.

6. Exclusions of other representations.

Enviroconcepts International excludes all other representations, warranties, conditions and promises in relation to the quality, fitness or suitability of the product except those which are set out in this warranty and/or by virtue of law, cannot be excluded.

7. What Enviroconcepts International must do to honour this Warranty.

If you make a claim, Enviroconcepts International will assist you wherever possible to get the problem rectified. We will then verify and promptly inspect your claim and advise you whether this warranty applies to your claim.

Assuming the claim falls within this Warranty, Enviroconcepts International will notify you on how it intends or proposes to fix the defect(s) and carry out those works promptly.

In the case of a Pass-through Warranty as may apply to certain items, Enviroconcepts International will happily aid you in replacement of the faulty product at your cost. Upon return of the faulty product to the manufacturer and successful warranty claim, Enviroconcepts International will credit your account accordingly.

If the issue is highly technical, we may choose to put you in touch with the manufacturer for diagnosis or to assist in the warranty claim.

8. What you must do and how to claim.

To make a claim you must contact Enviroconcepts International in writing using the details stated in the letterhead above.

You must provide Enviroconcepts International with the following information and any other additional information that may be requested within 7 days of the defect becoming evident.

- Address where the product was installed;
- Date of the installation;
- Details about the nature and extent of defect(s) ;
- How you came to diagnose and confirm
- Events leading up to the issue.
- Detailed and specific photos and/or video.
- Diagnosis report from a local technician relevant to the fault/part i.e: Plumber or Electrician.

To entitle you to claim, you must give Enviroconcepts International the opportunity to investigate your claim prior to engaging any other person to investigate or carry out works on the Product. A failure to do so may void this warranty.

If a replacement part is required, a new part must be purchased through Enviroconcepts International and will be sent upon receipt of payment under your standard account terms, as soon as the part becomes available.

The faulty part must be sent back to Enviroconcepts International within 30 days of the Warranty Claim being lodged. Upon evaluation, your account will be credited if the warranty claimed is accepted.

Items must be sent at your cost via traceable parcel and the tracking number must be provided to Enviroconcepts International on the day of dispatch.

Items sent outside of the abovementioned timeframe without a tracking number provided are not guaranteed to be covered by any warranty. If you have special requirements and require more time before being able to send the parts for evaluation, you must notify Enviroconcepts International immediately.

9. Can I transfer this product Warranty?

No, this product warranty is not transferable.

10. Do I have to pay the cost of making a claim?

Enviroconcepts International will not charge you for processing your claim on the Warranty. If this Warranty responds to your claim, Enviroconcepts International will be responsible for Product repair or replacements costs only. You are responsible for the following costs:

- Those incurred by you in making a claim;
- Any costs incurred prior to Enviroconcepts International being made aware of your claim;
- Freight and delivery of any diagnostic or replacement parts;
- All service and/or labour costs associated with the works completed under this warranty; and
- All investigation costs of your claim if the investigation reveals the claim is not covered by this warranty. In which case Enviroconcepts International will issue you an invoice to be paid without delay.

11. Warranty in addition to rights under law.

The benefits to you under this Warranty are in addition to the other rights and remedies you have under a law in relation to the goods and services to which the warranty relates.

Warranty Executed by;



Alexander Winter

Director

Enviroconcepts International Pty Ltd

info@enviroconcept.com.au

1300 661 130



Specific Equipment



Diaphragm Pump Manual



Table of Contents

1.	INSTALLATION INSTRUCTIONS	3
1.1	General	3
1.2	Rotation.....	3
1.3	Pipe Work	3
1.4	Electrical	3
1.5	Gear Reducer	3
1.6	Engine Drives.....	3
1.7	Start Up.....	3
1.8	Important information for installers – Internal Pipe Size for Diaphragm Pumps.....	3
1.9	Maintenance.....	3
1.10	Diaphragm Installation Instructions.....	4

1. INSTALLATION INSTRUCTIONS

In the rare occurrence where the diaphragm pump is required to be installed on site by either yourselves or your plumber, please see the below instructions

1.1 General

Install the pump on a level and secure surface using holes in the base plate.

Remove vent plug from gear reducer oil filler cap.

Check oil is visible in the sight glass. Use high quality 460 grade gear oil. ASM Diaphragm pumps do not require priming and can run dry without damage. For startup ensure all valves are fully open before running the pump. With the pump delivering liquid check the motor current draw is below the full load current on the motor nameplate.

1.2 Rotation

Correct motor rotation is clockwise – viewed from the fan end of the pump.



WARNING: Incorrect rotation will damage the pump and void warranty.

1.3 Pipe Work

Correct pipe size is a critical factor affecting pump performance and service life. Refer to pipe selection chart below. Pipework should be airtight, adequately supported and as short and direct as possible. Use flexible connectors between pump and rigid pipe work. Fit an ASM Pulsation Dampener if rigid pipework exceeds 3m in length. For flexible installations use reinforced suction hose for suction and discharge.



WARNING: Never restrict or dead head the pump discharge, damage will occur. Use of incorrect pipe sizes will void warranty.

1.4 Electrical

Have the electrical connection installed by a qualified electrician. Connect motor as per the motor manufacturers instructions and fit a motor overload protection device. Ensure there is unobstructed airflow to the motor cooling fan and the motor is protected from the weather and water. The correct motor rotation is clockwise viewed from the fan end.

1.5 Gear Reducer

Check oil is visible in sight glass before start up. Recommended Oil – Shell Omala 320 or Castrol Alpha SP320.



WARNING: Remove vent from oil filler cap.

1.6 Engine Drives

Refer to manufacturer's instructions for commissioning

1.7 Start Up

Diaphragm pumps do not require priming and can run dry without damage. Open valves and run the pump. With the pump delivering liquid check motor current draw is below the full load current on the motor nameplate.

1.8 Important information for installers – Internal Pipe Size for Diaphragm Pumps

For Clean liquids with the same viscosity as water.

Pump Size		Suction Pipe Length 0-5m	Suction Pipe Length 5-10m	Discharge Pipe Length 0-5m	Discharge Pipe Length 5-10m	Discharge Pipe Length 10-20m
D25	Suction Pipe ID	25mm	32mm	32mm	40mm	40mm
D32		32	40	40	50	50
D38		40	50	50	65	65
D50		50	65	65	80	80
D76		80	80	80	100	100



WARNING: Use of pipes smaller than recommended will void warranty

1.9 Maintenance

After 10 Hours operation check the oil level in the gear reducer and re-tension fasteners if required. After 100 Hours drain reducer, flush thoroughly with a light oil and replace with 460 grade gear oil. Replace gear reducer oil every 2500 Hours thereafter. The operator should not need to carry out further maintenance, rather inspect the pump on a regular basis and be aware of changes to the pump's normal operation. Diaphragm and valve assemblies are consumable items and will require replacement.

1.10 Diaphragm Installation Instructions

- Jog pump to take the diaphragm, Item 3 to the bottom of the stroke.
- Disconnect power supply. Remove the four clamping bolts holding the drive support housing, Item 12 to the bowl casing, Item 1 and lift the drive support and diaphragm assembly clear.
- Remove stainless bolt Item 9 for D25 and D32 or nut for D38, D50 and D76. Remove the washer set set Item 10 and diaphragm plate Item 2.
- Clean and inspect both diaphragm plates and replace washer set. Replace diaphragm. The correct orientation is with the writing up. See Fig.1
- The top outer lip of the diaphragm should be 0 - 2mm from the drive support housing clamp face. See Fig.2 below.
- The diaphragm position will generally not require adjustment. If required, loosen and adjust the connecting rod nut/s.
- Mount the drive support and diaphragm assembly onto the bowl casing ensuring the diaphragm is central and located in the groove of the bowl and fit the four clamp bolts.

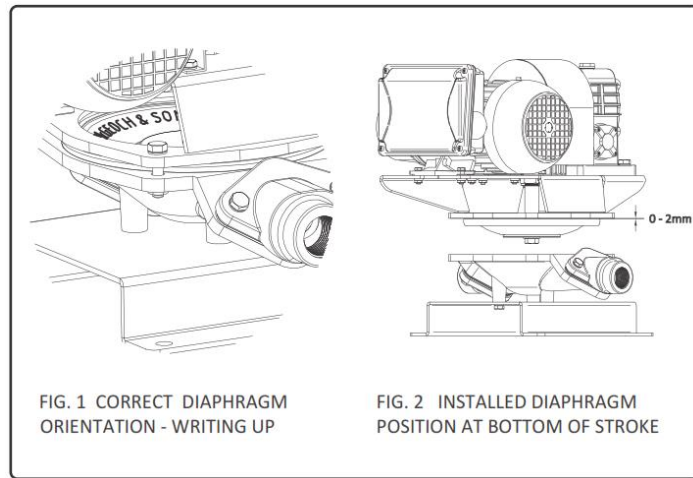
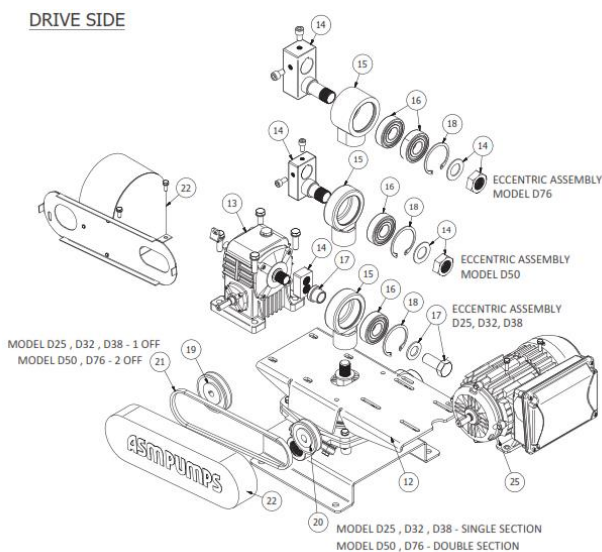

FIG. 1 CORRECT DIAPHRAGM ORIENTATION - WRITING UP

FIG. 2 INSTALLED DIAPHRAGM POSITION AT BOTTOM OF STROKE



D SERIES PUMP PARTS LIST		
ITEM	DESCRIPTION	QTY.
1	Bowl Casing	1
2	Diaphragm Plate	2
3 *	Diaphragm	1
4	Suction Valve Body	1
5	Discharge Valve Body	1
6 * #	Valve Seat - Stainless	2
6G * #	Valve Seat Gasket - Rubber	2
7 * #	Flap Valve	2
8 * #	Flap Valve Weight Set	2
9	SS Bolt / Nut	1 / 2
10 *	Washer Set	1
11	Connecting Rod	1
12	Drive Support Housing	1
13	Gear Reducer	1
14	Eccentric Block Assembly	1
15	Eccentric Housing	1
16	Eccentric Bearing	1 OR 2
17	Eccentric Bolt & Spacer	1
18	Circlip	1
19	Gear Reducer Pulley	1
20	Motor Pulley	1
21 *	V-Belt	1 OR 2
22	Gaurd Assembly	1
23	Carry Frame	OPT.
24	Base Plate	1
25	Motor	1
VA	Valve Assembly	2
K1	Service Kit	1
* Part Included in K1 Service Kit		
# Part Included in VA Valve Assembly		
For ordering Part No. = Model - Item No.		

FLUID SIDE

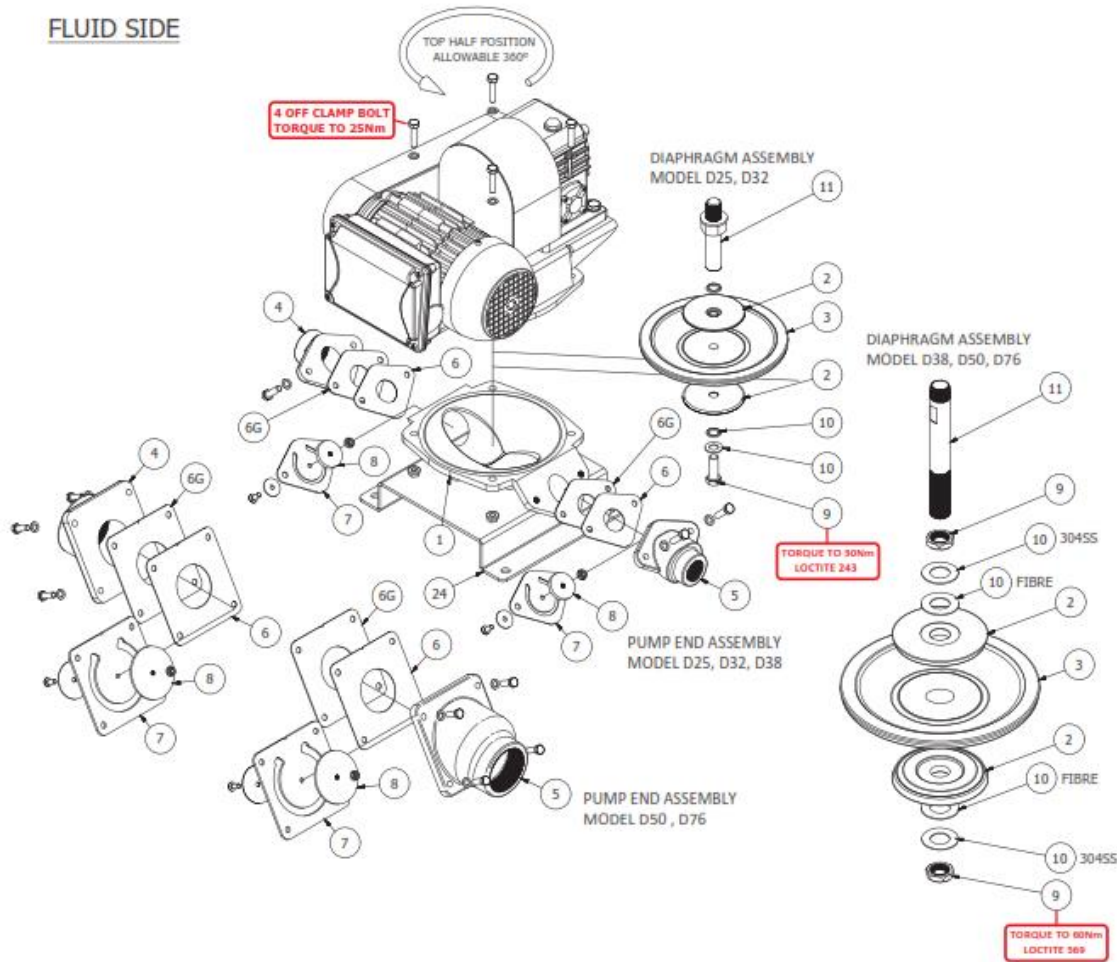

PD1 & PD2 PULSATION DAMPENER PARTS LIST	
ITEM	DESCRIPTION
1	Top Half
2	Bottom Half
3	Diaphragm

DIAPHRAGM ORIENTATION
Discharge - Concave (as shown)
Suction - Convex



Oil Water Separator Operating Manual

Rev 2 18/09/2018



Table of Contents

1	INTRODUCTION.....	3
1.1	Initial Handling and Inspection.....	3
1.2	Important Notice.....	3
1.3	Your legislative requirements.....	3
2	TRANSPORTATION & STORAGE.....	3
2.1	Receiving and Inspection of the Equipment.....	3
2.2	Typical Loading/Unloading of the equipment.....	3
3	OPERATOR SAFETY	4
3.1	Make it safe first.....	4
3.2	Before operating.....	4
4	APPLICATION DESCRIPTION	4
5	DESIGN CONDITIONS	4
6	PRINCIPLES OF OPERATION.....	5
7	INSTALLATION INSTRUCTIONS.....	5
8	OPERATING INSTRUCTIONS.....	6
9	MAINTENANCE.....	6
9.1	Inspecting & Servicing.....	6
9.2	When to Service your OWS?.....	7
10	SPARE PARTS	7
11	DRAWINGS	7

1 INTRODUCTION

Thank you for purchasing your Enviroconcepts, OWS. This manual has been prepared to help you to understand, setup, operate and troubleshoot your system. This package has been designed so that minimal maintenance will be needed to keep it operating efficiently.

Before operating the user should be thoroughly familiar with equipment operation, limitations and hazards. Thoroughly read, understand and observe all safety and operating instructions. Please note – System components may vary with your system please disregard / ignore system component instructions that are not relevant to your system. If you are unsure, please contact Enviroconcepts.

1.1 Initial Handling and Inspection

By following the instructions, you will have opened the equipment and found it to be in good condition or damaged.

If the equipment was delivered to you by a common carrier and damage is found, even hidden damage, IMMEDIATELY file a claim with your carrier. Their representatives must inspect and verify the damage. It is your responsibility, not Enviroconcepts, or your distributors to file the freight damage claim.

Check the enclosed packing list to verify that all items have been received. Contact your distributor or Enviroconcepts if assistance is needed with common carriers, identification of parts or installation process.

1.2 Important Notice

The following information is necessary for installation, parts, service and warranty consideration.





Serial Number _____ Model Number: _____

1.3 Your legislative requirements.

Customers purchasing these products will be subject to trade waste charges. These charges may vary between different water or sewer service providers in each circumstance.

You will need to ensure you have trade waste approval prior to installation.

Contact your local sewerage network provider for proper instruction and advice.

-  **IMPORTANT:** Any electrical work must be undertaken by a qualified electrician.
-  **IMPORTANT:** Always follow the MSDS, SWMS and any JSAs specific to your site prior to undertaking any system changes that cause any harmful effects.
-  **WARNING:** Observe and do not remove any warning and safety labels on the system.
-  **WARNING:** All guards, shields and covers must be in place to prevent accidental contact with hazardous parts.
-  **WARNING:** Never stand in water when cleaning, contacting or working with electrically powered equipment.

2 Transportation & Storage

2.1 Receiving and Inspection of the Equipment

Depending on the product, the equipment may be delivered fully assembled or in flat-pack form for local assembly. Upon delivery, immediately inspect the goods and report any visible damage. Notify Enviroconcepts of any defect or damage and include photographic evidence.

2.2 Typical Loading/Unloading of the equipment

Before doing any work, an appropriate lift study needs to be undertaken by a qualified person before commencing the lift. The lifting procedures specified in this manual are only generic guidelines and should be reviewed for suitability depending on actual site conditions.

Planning, selection and operation of crane must be done in accordance with AS/NZS 2550.1-2011. Check the empty equipment weight and select appropriate rated and sized lifting equipment.

3 Operator Safety

When in doubt, contact Enviroconcepts on 1300 661 130.

Remember that the equipment may operate automatically and can start at any time. Isolate any equipment before working on it or asking others to work on it.

3.1 Make it safe first.

Always make the unit safe by flushing out any chemical residues from the pumps and pipelines and isolating the equipment.

Always electrically isolate the equipment and switch off the local isolator **before** you dismantle any electrical equipment. Remember that equipment can be turned on by accident.

Do not undertake any works unless the consequences are carefully thought through. Many pipelines contain chemicals or effluent under pressure even when the equipment has been shut down for some time.

All warranties and guarantees with respect to the function and durability of the system shall be void should the operator fail to adhere to these safety instructions or any other instructions within this Guide.

The associated risks due to failure to adhere to these safety instructions include but are not limited to:

1. Endangering people due to electrical, mechanical, and/or chemical/biochemical hazards.
2. Endangering the environment due to leakage of hazardous material (where chemicals are involved).
3. Failure of important equipment and process functions leading to inferior performance.

3.2 Before operating.

The user should be thoroughly familiar with equipment operation, limitations, and hazards. Thoroughly read, understand, and observe all safety and operating instructions Please note – System components may vary with your system please disregard/ignore system component instructions that are not relevant to your system. If you are unsure, please contact Enviroconcepts on 1300 661 130.

4 APPLICATION DESCRIPTION

Wastewater will enter the above-ground ECOWS where free oils will coalesce and float to the surface and overflow the oil outlet pipes to a waste oil drum. Heavy suspended solids will settle and sink into the base hopper where they can be evacuated manually by ball valve, generally back to the pit the wastewater originated from. The pre-treated effluent will continue through to the outlet funnel where it will evacuate by gravity for discharge or further processing.

5 DESIGN CONDITIONS

ECOWS-030 - Maximum Inlet Flow Rate	1,800 L/hr
ECOWS-050 - Maximum Inlet Flow Rate	3,000 L/hr
ECOWS-100 - Maximum Inlet Flow Rate	6,000 L/hr

This range of units have the following design parameters:

Oil Types	Engine Oil, Gasoline, Diesel, Lubricant, etc.	
Typical Oil SG	0.85 @ 25 °C	(note: will vary depending on oil type and temperature)
Operating Temperature	25 °C	(note: temperature affects OWS performance)

See below typical performance,

Inlet Oil Concentration	100 ppm	
Outlet Oil Concentration	< 5 ppm(Inlet by Gravity Flow)	
	< 10 ppm	(Inlet Diaphragm Pump, less than 60 strokes per minute)
	< 15 ppm	(Inlet Progressive Cavity Pump, > 1,000 revs per minute)
	< 30 ppm	(Inlet by Centrifugal Pump, less than 1,800 revs per minute)

Inlet Oil Concentration	750 ppm	
Outlet Oil Concentration	< 25 ppm	(Inlet by Gravity Flow)
	< 50 ppm	(Inlet Diaphragm Pump, less than 60 strokes per minute)
	< 75 ppm	(Inlet Progressive Cavity Pump, > 1,000 revs per minute)
	< 150 ppm	(Inlet by Centrifugal Pump, less than 1,800 revs per minute)

Typical wash bay effluent will be in the 50-200 ppm range. Some industrial trade wastewater may be higher.

No chemical emulsions, surfactants, detergents or water-soluble degreasers should be present.

If required, only Quick Break and Biodegradable Detergents and Degreasers may be used and only in minimal quantities.

The application and type of wastewater, including chemicals added in the process, will vary the expected output.

6 PRINCIPLES OF OPERATION

Like all gravity separators, the ECOWS range depends on Stokes' Law for its performance prediction. Stokes' Law is the physical law governing the settling or rise rate of a particle or oil droplet in a fluid stream and along with various design parameters, determines the size and type of OWS unit.

Contaminated water is introduced into the first section of the OWS via gravity flow. Heavy solids settle out immediately and fall into the hopper, whilst large oil particles rise to the surface.

The remaining oily water mixture flows through the closely spaced proprietary oleophilic coalescing plates with the smaller oil droplets and fine suspended solids being progressively separated. An oil dam prevents the collected (floating) oil from escaping into the outlet pipe. Adjustable Oil skimmers are provided for the removal of the accumulated oil.

Pre-Treated Effluent water passes underneath the base of the oil dam, over the outlet weir (funnel) and gravitates to the point of discharge

7 INSTALLATION INSTRUCTIONS

PLEASE REFER TO THE INSTALLATION GUIDELINES IN DIAGRAM ON PAGE 12.

The basic steps for installation of the OWS are as follows:

1. Select a sound, level foundation for locating the OWS.
2. Secure to the foundation with 10-12mm diameter corrosion resistant fasteners.
3. Connect the clean water outlet pipe to the outlet connection of the OWS.
4. Connect the oil outlets from the oil skimmers to the oil collection drum or tank. A normally open valve may be installed in the oil outlet line, if required for isolation purposes.
5. Install a ¼ turn valve on the solids outlet at the base of the hopper. If required install piping back to the dirty water collection tank or a sludge drying pit if available.
6. All pipe work is to be independently supported, not supported by the separator connection nozzles.
7. When installing a bund, its minimum capacity should be equal to the volume of your unit. (ECOWS-030 = 185 Litres, ECOWS-050 = 200 Litres, ECOWS-100 = 441 Litres) and drain back into the dirty water collection tank.

Fitting Sizes

ECOWS-030 and ECOWS-050

- The dirty water inlet and clean water outlet are in 40mm BSP threaded female connections.
- The solids outlet is 50mm BSP threaded female connections.
- The two oil skimmer outlets are 25mm BSP threaded male connections.

ECOWS-100

- The dirty water inlet and clean water outlet are in 50mm BSP threaded female connections.
- The solids outlet is 50mm BSP threaded female connections.
- The two oil skimmer outlets are 40mm BSP threaded male connections.

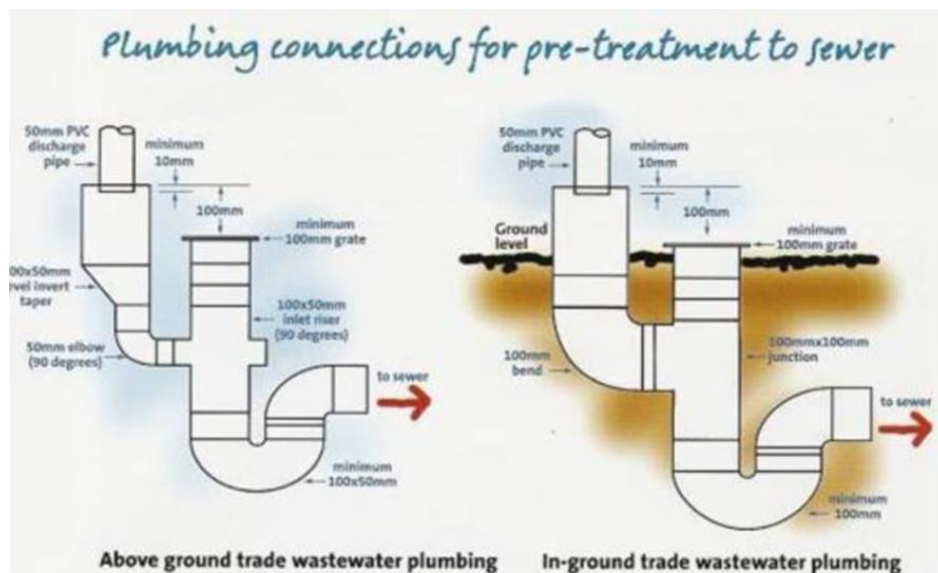

8 OPERATING INSTRUCTIONS

Initial Startup

This procedure is to be followed after installation or after the unit has been drained, cleaned and is ready to be brought back into operation.

1. Ensure that the waste water inlet is not allowed to flow by isolating the feed pump or gravity feed.
2. Set the oil skimmers high, approx. 35mm above the threaded oil skimmer pipe. Ensure that there are no obstructions in the oil or water outlet piping and remove any foreign matter if necessary.
3. Ensure Oil Waste drums are empty and in place
4. Ensure all fittings are tight and secure.
5. Fill the OWS with clean water until water starts to flow over the outlet weir (funnel).
6. Check for leaks or blockages at the outlet.
7. Now allow the inlet water to enter under typical conditions. If you typically use a pump, make sure you use the pump. This way you can set the oil outlet skimmers at the correct height under normal operating conditions.
8. Note there are two oil skimming outlets. One at the entry end, one at the outlet end. They will be set at different levels. After the pump has primed & then operated for several minutes, set the top of the inlet oil skimmer socket approximately 5mm above the high water level and the discharge end approximately 3mm above the maximum operating water level by screwing the sockets up or down. Secure the lock nuts on each skimmer socket to ensure no movement.
9. Skimmers can be adjusted if necessary but remember that it is always acceptable for an oil layer of approximately 5-10mm to be maintained on the surface.
10. Always adjust oil skimmers relating to the MAXIMUM water level (i.e. at full flow conditions). Note that diaphragm pumps pulse the water level. It is important you set the skimmers based on the highest water level.

9 MAINTENANCE

The solids should be drained fortnightly by opening the valve on the solids hopper until solid free water is flowing (i.e. all the accumulated solids have been removed, usually a few seconds when fully open). Note: Any waste to be disposed of should be collected by a suitable contractor.

It is recommended that the unit be serviced regularly, the frequency being determined by the amount of solids built up in the plates at the time of the first inspection, which should take place approximately 3 months after installation.

A thin oil film present on the plates is normal. Cleaning need only be carried out if the plates are blocked by an oily sludge.

9.1 Inspecting & Servicing

1. The flow to the separator must be isolated before any servicing.
2. The oil skimmers can be lowered to remove accumulated oil from the surface of the OWS. The skimmers must be raised back up to the operating position.
3. Remove the plates by lifting slowly, allowing the water to drain back into the OWS.

Visual inspection will determine the amount of solids built up in the plates. If any of the plates appear to be silted up or partially blocked, they can be cleaned in one of the two following methods:

Method 1 – Cleaning In Situ

1. Makes sure the inlet flow is isolated during servicing.
2. Lower the plates back into the OWS and drain the water through the solids valve on the bottom of the hopper back into the collection tank or other suitable storage tank.
3. Hose down the plates with a hose or pressure washer until all sludge and oil has been removed. Remove any built up solids by hosing underneath the packs, ensuring no sludge remains in the OWS.
4. Follow Initial Start-up instructions above to return to operation.

DO NOT USE ANY DETERGENTS

Method 2 – Cleaning in a Bunded Area

1. Makes sure the inlet flow is isolated during servicing.
2. Drain the OWS through the solids valve on the bottom of the hopper back to the collection tank or gutter.
3. Remove the plate packs from the OWS and place into Bund or on the washbay.
4. Hose the plates thoroughly (in a bunded area draining back into the collection tank), ensuring any built up sludge is removed.
5. Hose the inside of the OWS, ensuring all collected sludge and oil is removed.
6. Replace cleaned plate packs back into the OWS and fill with clean water until water starts to flow over the outlet weir.
7. Follow Initial Start-up instructions above to return to operation.

DO NOT USE ANY DETERGENTS

9.2 When to Service your OWS?

Often, the service timeline requirements are dictated by your local governing authority. However, if there is no preset rules or guidelines, the quantity of sludge found in the hopper and in the plates can be used as a basis for determining the interval between subsequent cleaning operations.

A thin film of oil on the surface of each plate is normal. As is a 5-10mm crust of oil scum on the surface of the separator. The only main maintenance function is to ensure the plates cells are kept free of blockage to ensure the coalescing continues without obstruction.

If you carried out your first service at 3 months, and the plates were relatively clear and free of obstruction, you can consider making the next service date 4 months. Then you may push the next date out 5 months depending on what you find on the next service.

Collection Tank Cleaning:

At frequencies, depending upon the build-up of sludge and oil, the collection tank should be emptied (sucked out by a suitable contractor) and cleaned so that all sludge and oil has been removed. Scrape the walls of the collection tank to clean if necessary.

10 SPARE PARTS

No spare parts are required for this unit. Should any plates or oil skimmer parts become damaged they can be repaired or replaced by contacting your supplier.

11 Drawings

- a) ECOWS-030
- b) ECOWS-050
- c) ECOWS-100
- d) INSTALL GUIDELINES

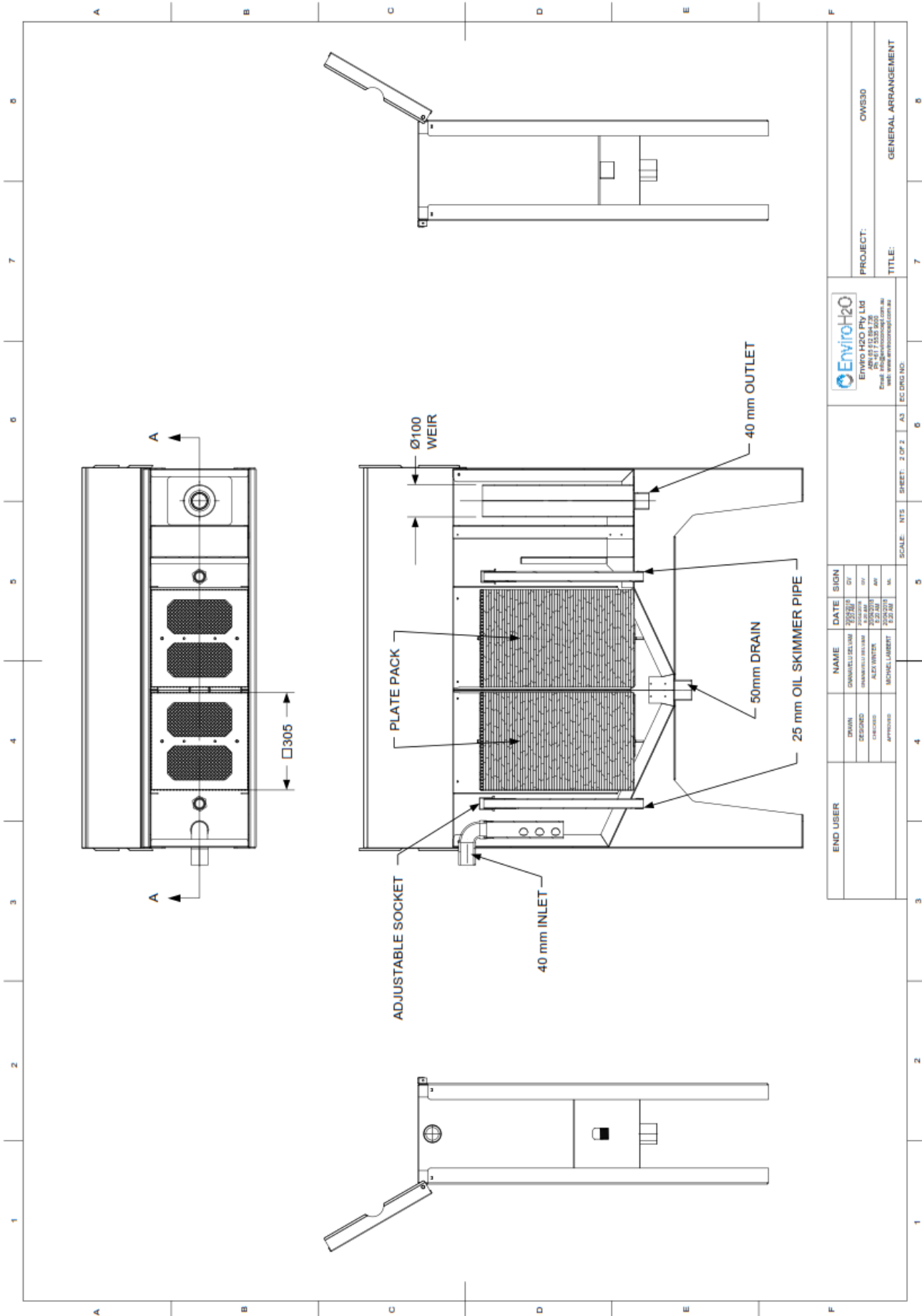

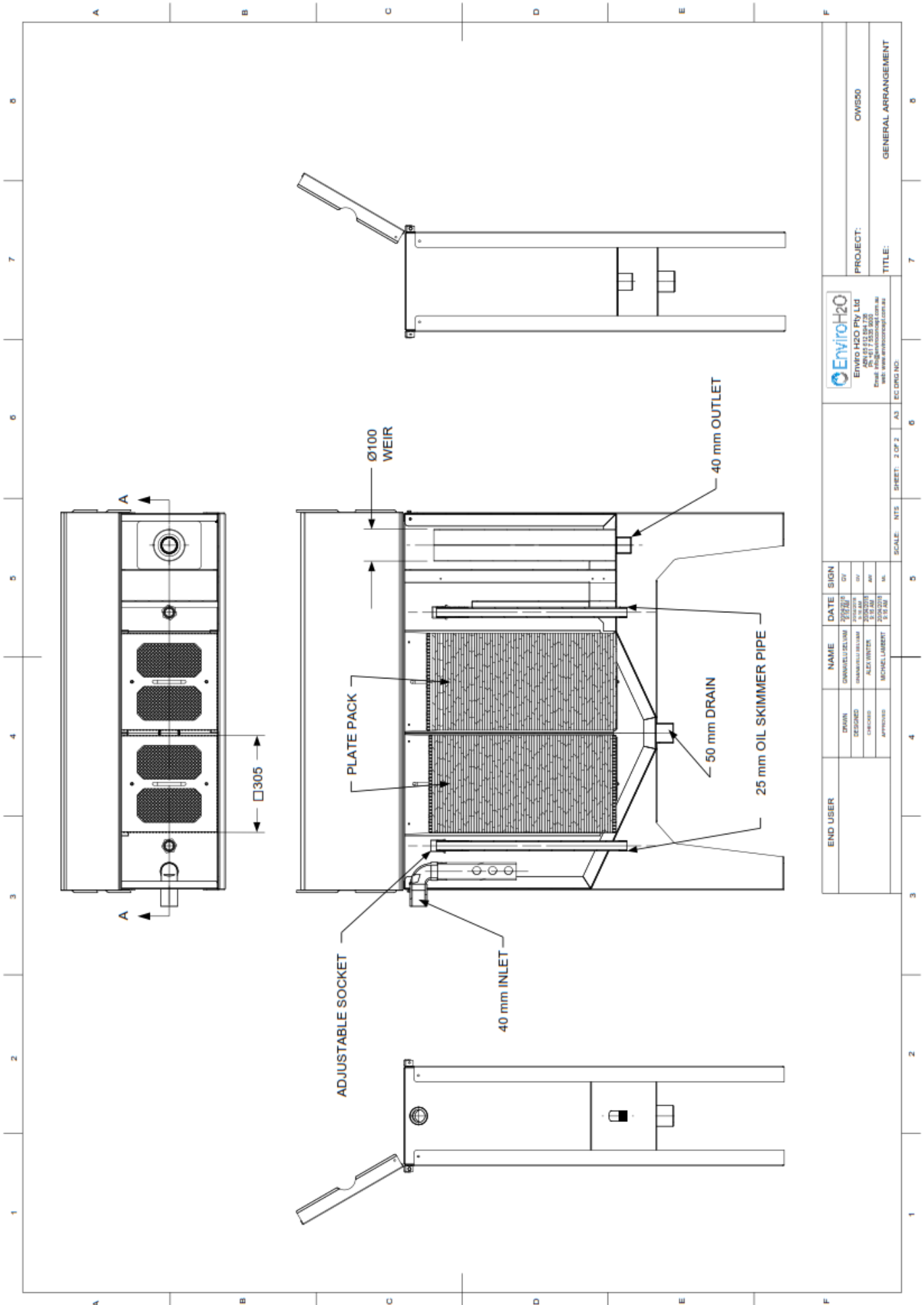

END USER		NAME	DATE	SIGN
DRAWN	DIMANVELLI SELAM	20/02/20	DT	
DESIGNED	DIMANVELLI SELAM	20/02/20	DT	
CHECKED	ALEX WINTERS	20/02/20	AW	
APPROVED	MICHAEL LAMBERT	19/02/20	ML	
PROJECT:		ECOWS50		
TITLE:		GENERAL ARRANGEMENT		
SCALE:		NTS	SHEET: 2 OF 2	A3
ECOWS NO.:		6		

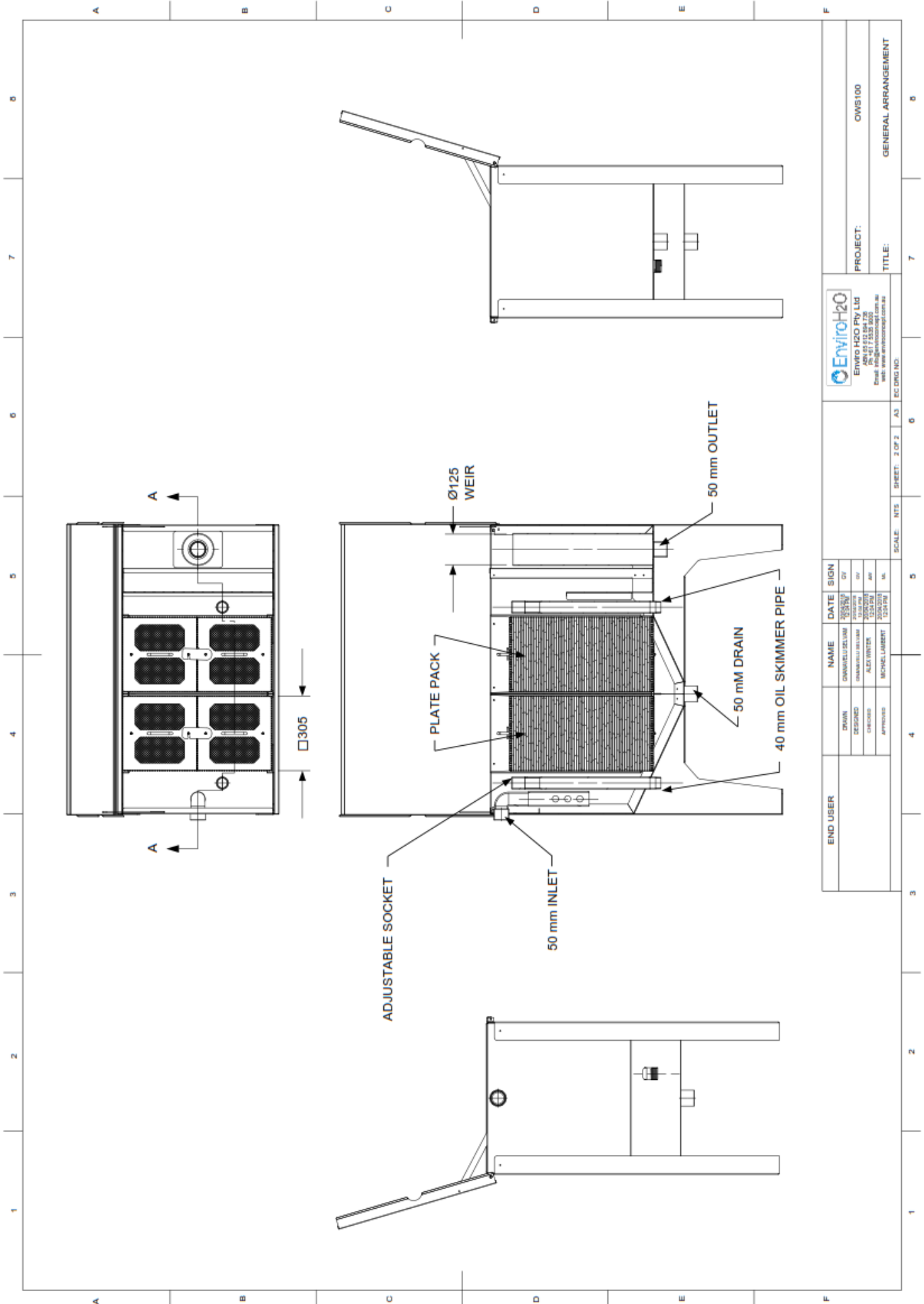

		PROJECT: ECOWS100	
Enviro H2O Pty Ltd ABN 61 612 04 1726 Email: info@enviroconcept.com.au web: www.enviroconcept.com.au		TITLE: GENERAL ARRANGEMENT	
END USER		NAME: DANIELLO BELLIAM DATE: 20/03/14 SIGN: DB	EC DRG NO:
DRAWN: DANIELLO BELLIAM CHECKED: ALEX JANTZEN APPROVED: MICHAEL LAMBERT	DATE: 20/03/14 SIGN: DB	SCALE: NTS SHEET: 2 OF 2	6
1	2	3	4
5	6	7	8

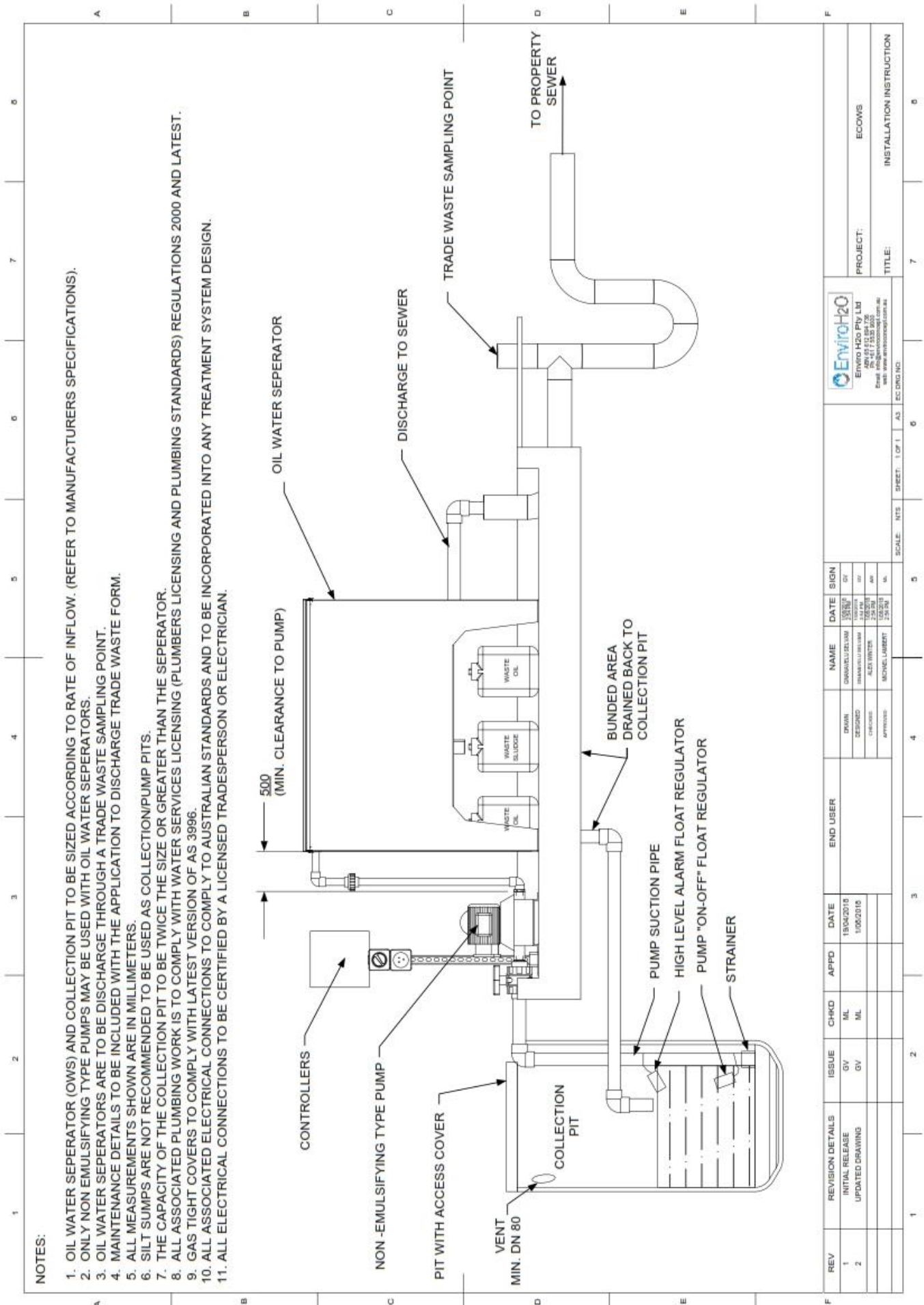

NOTES:

1. OIL WATER SEPARATOR (OWS) AND COLLECTION PIT TO BE SIZED ACCORDING TO RATE OF INFLOW. (REFER TO MANUFACTURERS SPECIFICATIONS).
2. ONLY NON EMULSIFYING TYPE PUMPS MAY BE USED WITH OIL WATER SEPARATORS.
3. OIL WATER SEPARATORS ARE TO BE DISCHARGE THROUGH A TRADE WASTE SAMPLING POINT.
4. MAINTENANCE DETAILS TO BE INCLUDED WITH THE APPLICATION TO DISCHARGE TRADE WASTE FORM.
5. ALL MEASUREMENTS SHOWN ARE IN MILLIMETERS.
6. SILT SUMPS ARE NOT RECOMMENDED TO BE USED AS COLLECTION/PUMP PITS.
7. THE CAPACITY OF THE COLLECTION PIT TO BE TWICE THE SIZE OR GREATER THAN THE SEPARATOR.
8. ALL ASSOCIATED PLUMBING WORK IS TO COMPLY WITH WATER SERVICES LICENSING (PLUMBERS LICENSING AND PLUMBING STANDARDS) REGULATIONS 2000 AND LATEST.
9. GAS TIGHT COVERS TO COMPLY WITH LATEST VERSION OF AS 3996.
10. ALL ASSOCIATED ELECTRICAL CONNECTIONS TO COMPLY TO AUSTRALIAN STANDARDS AND TO BE INCORPORATED INTO ANY TREATMENT SYSTEM DESIGN.
11. ALL ELECTRICAL CONNECTIONS TO BE CERTIFIED BY A LICENSED TRADESPERSON OR ELECTRICIAN.

REV	REVISION DETAILS	ISSUE	CHKD	APPD	DATE	END USER	NAME	DATE	SIGN
1	INITIAL RELEASE	GV	ML		19/02/2018		DANIEL BILBIM	19/02/2018	DB
2	UPDATED DRAWING	GV	ML		10/02/2018		ALDO BRITTO	10/02/2018	AB
							MONCLAUBERT	2/01/2018	MB

		PROJECT: ECOWS TITLE: INSTALLATION INSTRUCTION
Enviro H2O Pty Ltd ABN 61 553 900 726 PO Box 6664 GCMC QLD 9726 Email: info@enviroh2o.com.au web: www.enviroh2o.com.au		SCALE: NTS SHEET: 1 OF 1 A3 EC DRG/NO



EC-F-036
OWS Checklist

Date: 30/06/2018

Revision: 1

OWS (Oil Water Separator) Check List

Date of Inspection: _____

Client: _____

Checklist:	Initial		
	Checked	N/A	
1	OWS unit securely fastened down and free from damage		
2	Pipe work to OWS secure and free from damage and leaks		
3	Pipework from OWS to transfer pit secure and free from damage and leaks		
4	Lid of OWS has handles and lifts off easily		
5	Check overall condition of the OWS internally		
6	Check height of incoming oil drain		
7	Check height of outgoing oil drain		
8	Check condition of coalescing plates		
9	Check for clear no surging flow from OWS to transfer pit		
10	Check inside of OWS unit for build up of silt or debris		
11	Operate drain valve at base of OWS unit to ensure operation and check for leaks		
12	Wipe down unit		

ECI Technician Name: _____

ECI Technician Signature: _____

Client Name: _____

Client Signature: _____



Design Diagrams & Drawings

STANDARD

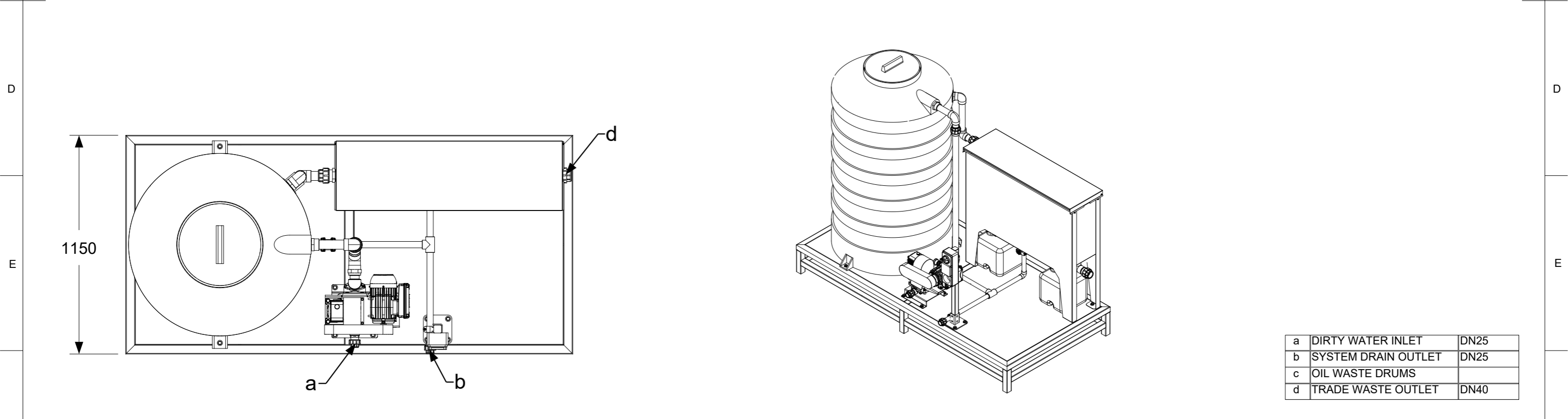
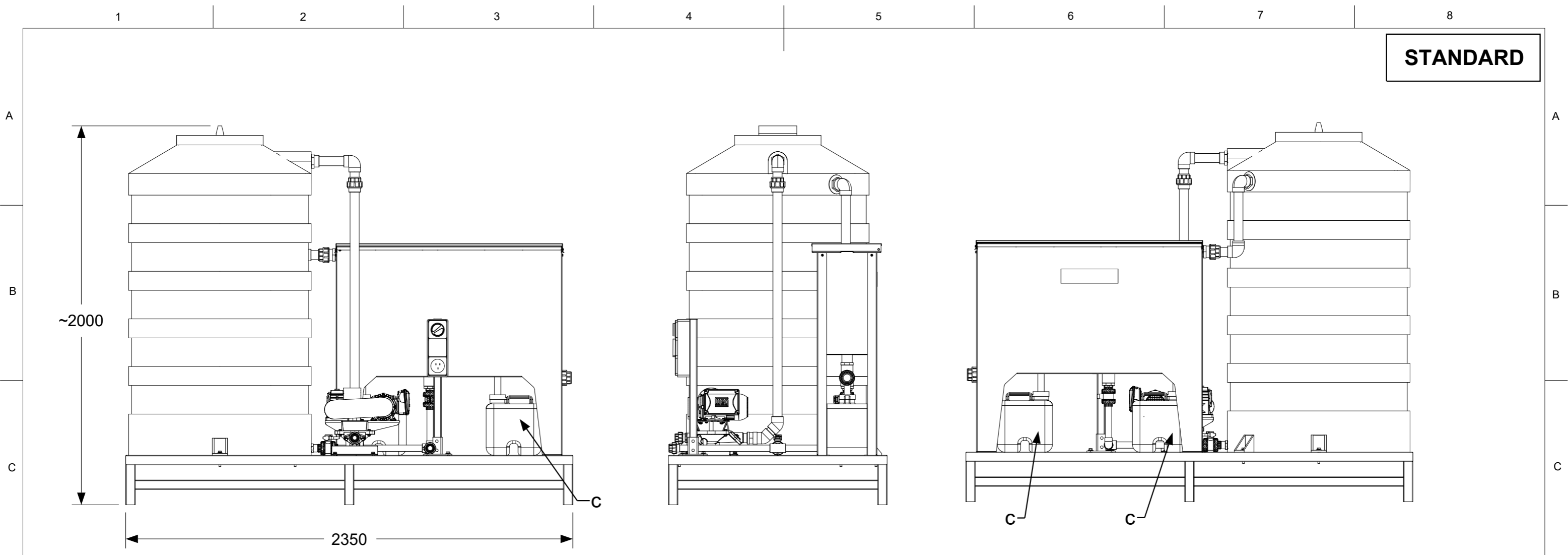

a	DIRTY WATER INLET	DN25
b	SYSTEM DRAIN OUTLET	DN25
c	OIL WASTE DRUMS	
d	TRADE WASTE OUTLET	DN40

REV	REVISION DETAILS	ISSUE	CHKD	APPD	DATE				NAME	DATE	SIGN	MATERIAL:				DRAWING NUMBER:
1	RELEASED FOR PRODUCTION	JW	JW		28/02/2020	UNLESS OTHERWISE SPECIFIED: TOLERANCES: 0 ± 1 0.0 ± 0.5 0.00 ± 0.1 DIMENSIONS ARE IN MILLIMETERS	DRAWN	JAMIE WANG	24/03/2020 2:59 PM	JW	THICKNESS:				DIM SIOS-030	
							DESIGNED	JAMIE WANG	24/03/2020 2:59 PM	JW				PROJECT:		
							CHECKED							TITLE:		
							APPROVED							DIMENSION DRAWING		
											SCALE: NTS	SHEET: 1 OF 1	A3			

Enviroconcepts International Pty Ltd
 ABN 65 612 894 738
 Ph +61 7 5535 9000
 Email: info@enviroconcept.com.au
 web: www.enviroconcept.com.au

DRAWING NUMBER: DIM SIOS-030
 PROJECT: SIOS-030
 TITLE: DIMENSION DRAWING

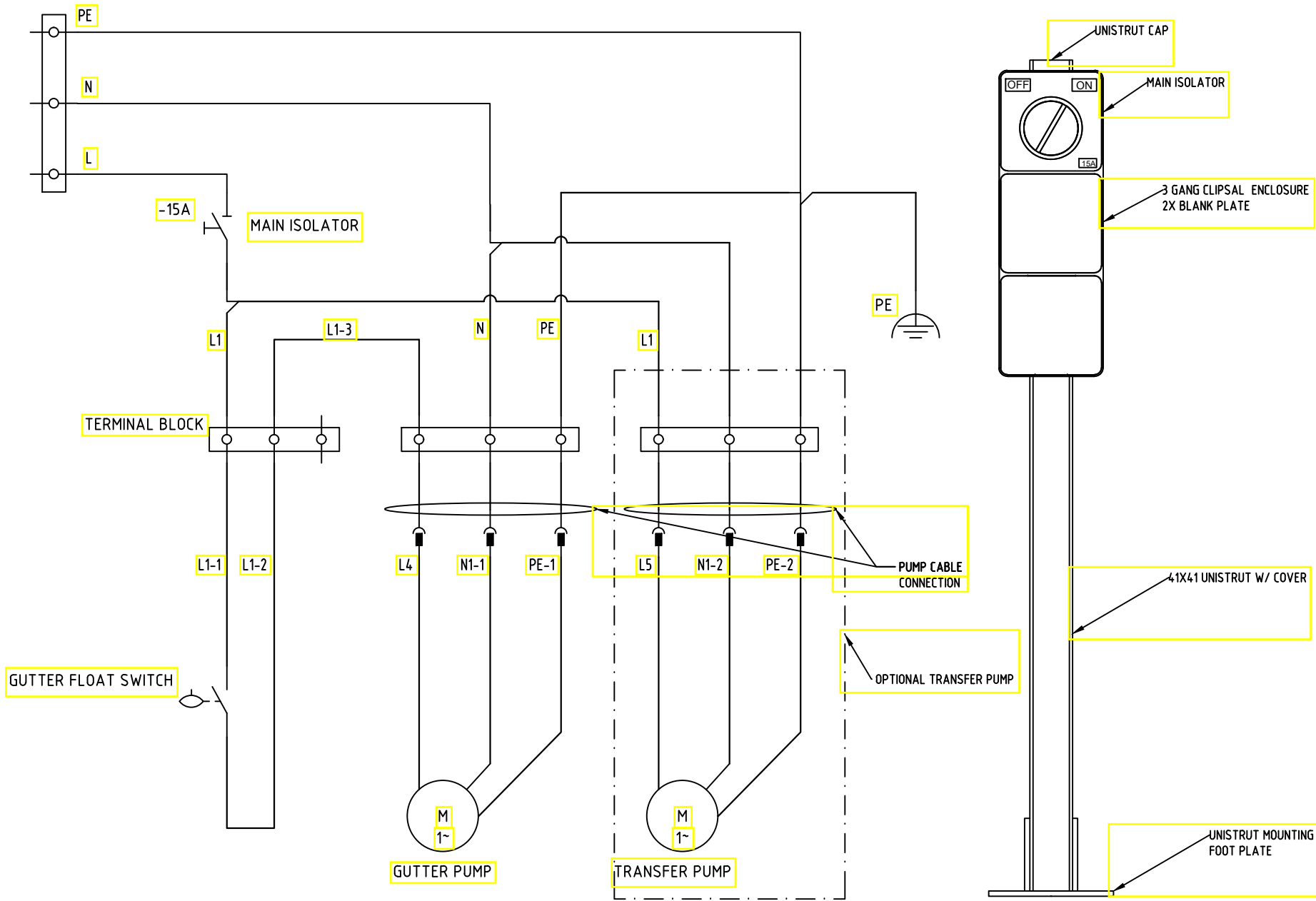

REV	REVISION DETAILS	ISSUE	CHKD	APPD	DATE	NAME	DATE	SIGN
1	PRELIMINARY DESIGN	PD	ML	SF	8/10/18	D.DUNCAN	10/01/19	DD
2	AS BUILT	AB	ML	SF	15/12/18	D.DUNCAN	10/01/19	DD
						CHECKED		
						APPROVED		
						SCALE: NTS	SHEET 1 OF 1	A3

Enviro H2o Pty Ltd
 ABN: 63-612-894-736
 Ph: +61 7 5535 9000
 Email: info@enviroconcept.com.au
 web: www.enviroconcept.com.au

CLIENT: 19 INDANA ST
 PROJECT: SIDS-30 STANDARD
 TITLE: ELECTRICAL SCHEMATICS CONTROL

EC DRG NO: SIDS-ELE-19101-001

PUMP DATA SHEET

D SERIES DIAPHRAGM PUMP – DS25

Description	Value
Pump Specifications:	
Model:	DS25
Port Size:	1" BSPF
Max Flow:	23 L/min
Max Suction Lift:	6m
Max Disch Head:	6m
Max Solid Size:	15mm Sphere
Motor Specifications	
kW:	0.25
RPM:	1480
Voltage:	240v
Full Load Current:	1.95A
IP Rating:	IP55
Materials:	
Diaphragm:	Nitrile
Valves:	Nitrile
Castings:	SG Iron

