

article			GRAF Australia Oil Water Separator SC 2000		article no.		31.0704	
drawn	ISC	weight	190 kg	comments		sampling point requirements to be confirmed by relevant authority of jurisdiction		
date	2024.05.08	tolerance	+/- 3%	scale	1:30	units	mm	
						GRAF Australia Pty Ltd 43b Sparks Road, Henderson WA 6166 info@grafaustalia.com.au www.grafaustalia.com.au		

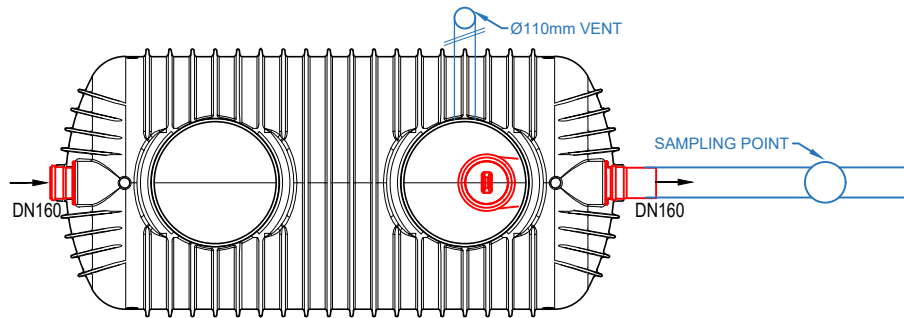

NOTE:  
 • RED ITEMS ARE PROVIDED  
 • BLUE ITEMS ARE EXCLUDED

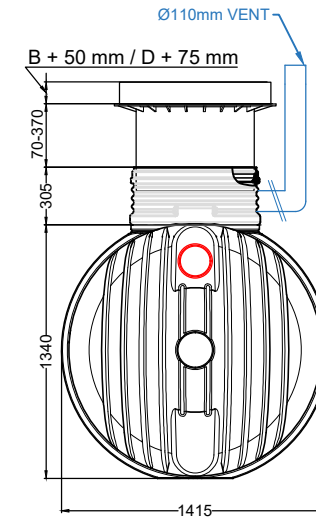
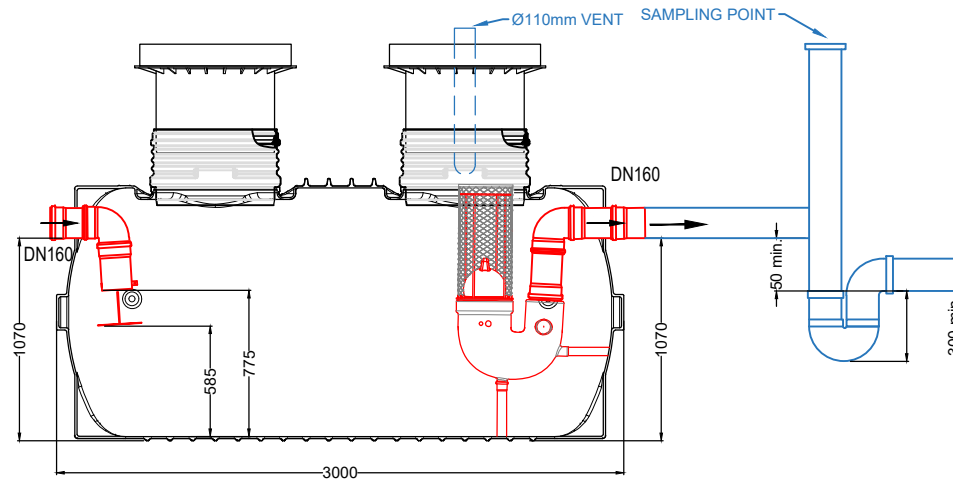

article			GRAF Australia Oil Water Separator SC 3000		article no.		31.0705	
drawn	ISC	weight	235 kg	comments		GRAF Australia Pty Ltd 43b Sparks Road, Henderson WA 6166 info@grafaustalia.com.au www.grafaustalia.com.au		
date	2024.05.08	tolerance	+/- 3%	sampling point requirements to be confirmed by relevant authority of jurisdiction				
				scale	1:40	units	mm	



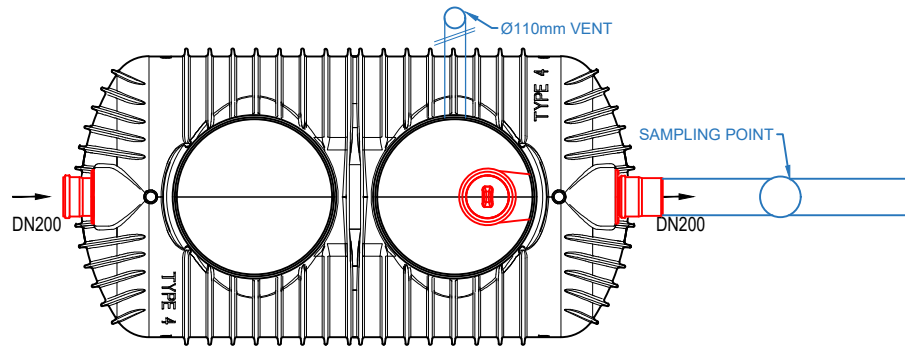

NOTE:  
 • RED ITEMS ARE PROVIDED  
 • BLUE ITEMS ARE EXCLUDED

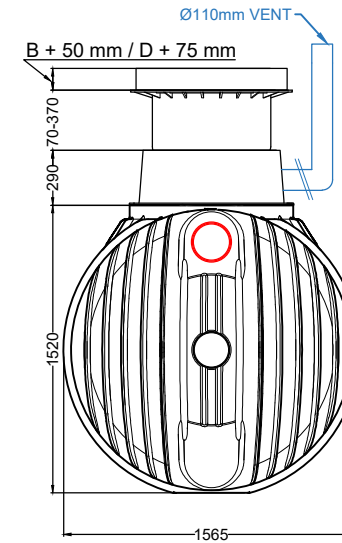
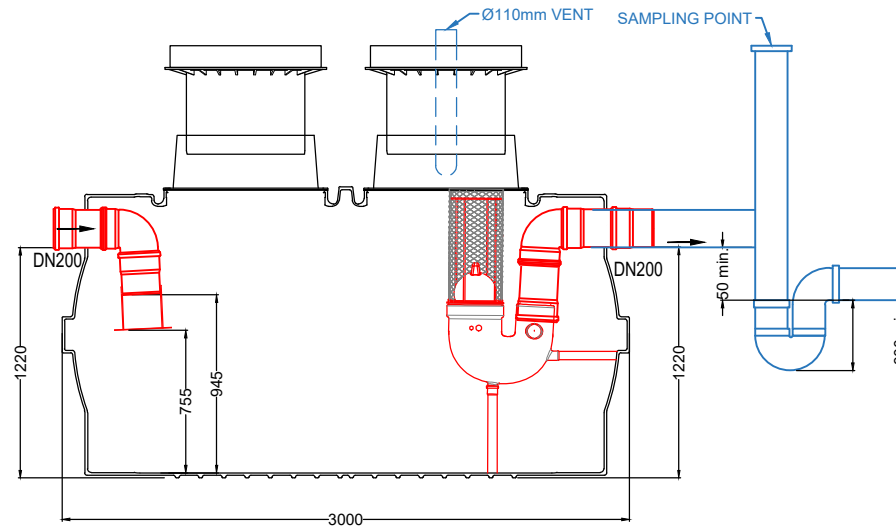



article <b>GRAF Australia Oil Water Separator SC 4000</b>			article no. <b>31.0706</b>	
drawn <b>ISC</b>	weight <b>285 kg</b>	comments sampling point requirements to be confirmed by relevant authority of jurisdiction		
date <b>2024.05.08</b>	tolerance <b>+/- 3%</b>	scale <b>1:40</b>	units <b>mm</b>	GRAF Australia Pty Ltd 43b Sparks Road, Henderson WA 6166 info@grafaustalia.com.au www.grafaustalia.com.au

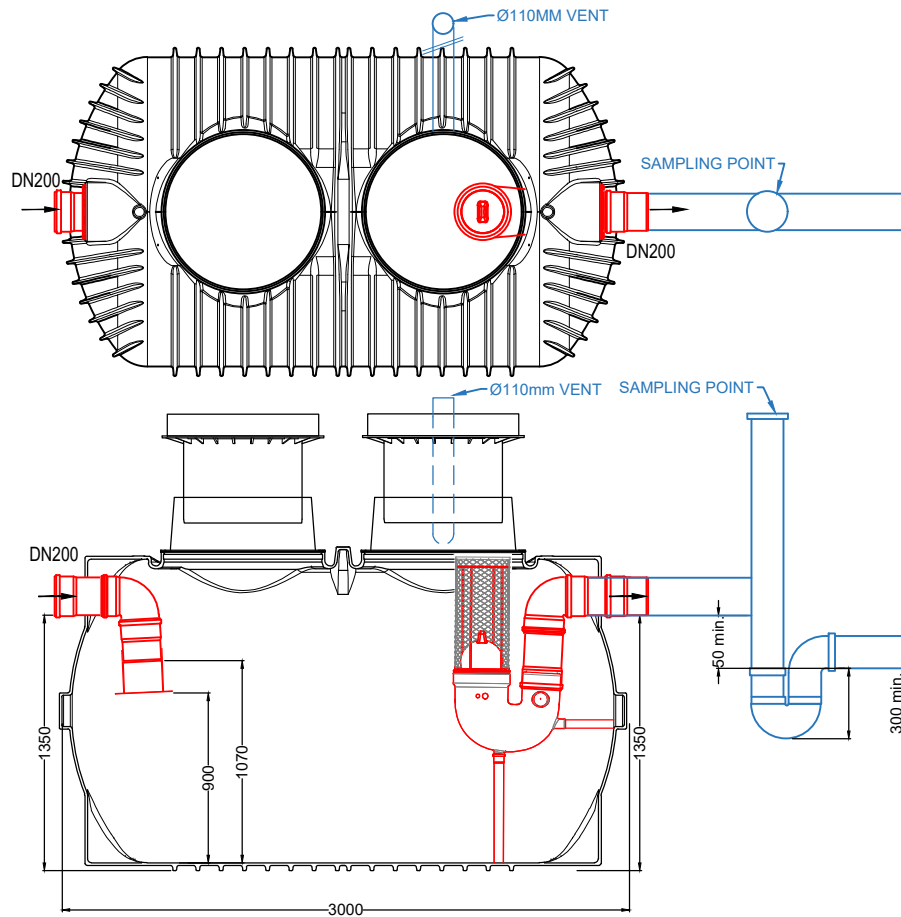

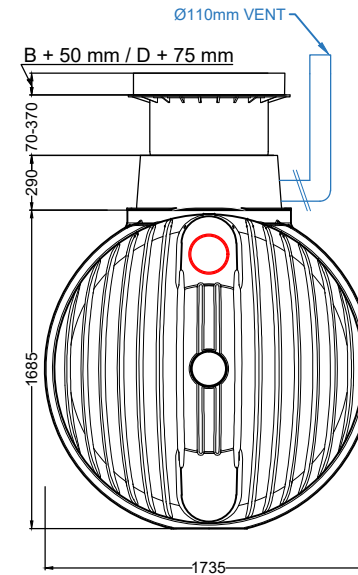

NOTE:  
 • RED ITEMS ARE PROVIDED  
 • BLUE ITEMS ARE EXCLUDED



article			GRAF Australia Oil Water Separator SC 5000		article no.	31.0707	
drawn	ISC	weight	355 kg	comments	GRAF Australia Pty Ltd 43b Sparks Road, Henderson WA 6166 info@grafaustalia.com.au www.grafaustalia.com.au		
date	2024.05.08	tolerance	+/- 3%	scale	1:40	units	mm
				sampling point requirements to be confirmed by relevant authority of jurisdiction			

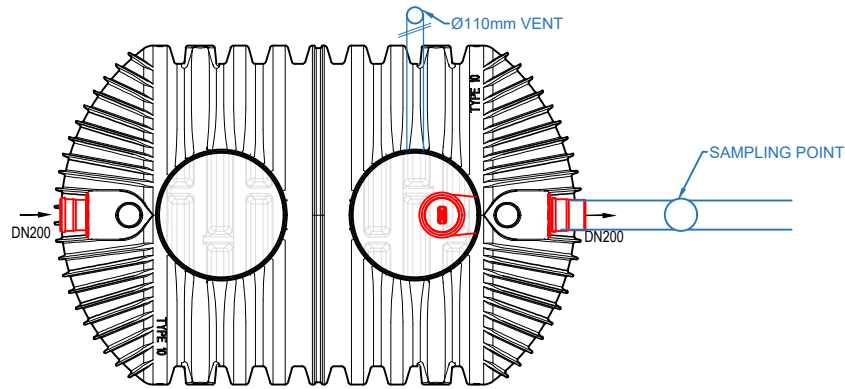

NOTE:  
 • RED ITEMS ARE PROVIDED  
 • BLUE ITEMS ARE EXCLUDED

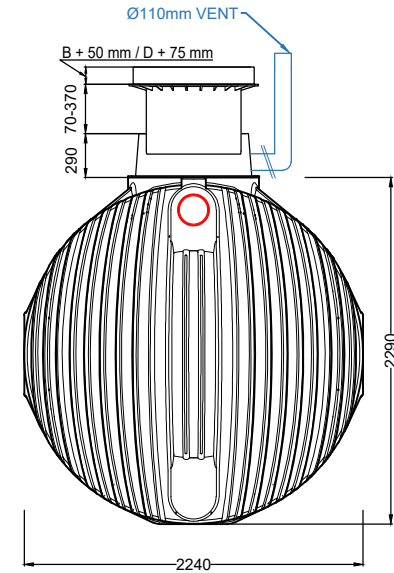
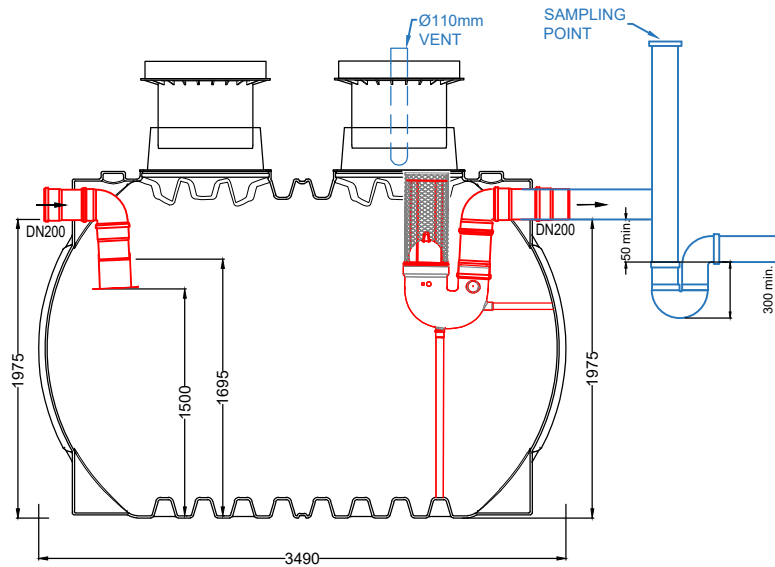

article			GRAF Australia Oil Water Separator SC 10000		article no.	31.0709	
drawn	ISC	weight	495 kg	comments	GRAF Australia Pty Ltd 43b Sparks Road, Henderson WA 6166 info@grafaustalia.com.au www.grafaustalia.com.au		
date	2024.05.08	tolerance	+/- 3%	scale	1:50	units	mm
				sampling point requirements to be confirmed by relevant authority of jurisdiction		