



Assets Planning and Delivery Group  
Engineering

## **DESIGN STANDARD DS 73-01**

---

### **Bulk Sodium Hypochlorite Storage and Dosing System - Basis of Design**

---

VERSION 1  
REVISION 4

MAY 2024

## FOREWORD

The intent of Design Standards is to specify requirements that assure effective design and delivery of fit for purpose Water Corporation infrastructure assets for best whole-of-life value with least risk to Corporation service standards and safety. Design standards are also intended to promote uniformity of approach by asset designers, drafters and constructors to the design, construction, commissioning and delivery of water infrastructure and to the compatibility of new infrastructure with existing like infrastructure.

Design Standards draw on the asset design, management and field operational experience gained and documented by the Corporation and by the water industry generally over time. They are intended for application by Corporation staff, designers, constructors and land developers to the planning, design, construction and commissioning of Corporation infrastructure including water services provided by land developers for takeover by the Corporation.

Nothing in this Design Standard diminishes the responsibility of designers and constructors for applying the requirements of the Western Australia's Work Health and Safety (General) Regulations 2022 to the delivery of Corporation assets. Information on these statutory requirements may be viewed at the following web site location:

[Overview of Western Australia's Work Health and Safety \(General\) Regulations 2022 \(dmirs.wa.gov.au\)](https://dmirs.wa.gov.au)

Enquiries relating to the technical content of a Design Standard should be directed to the Senior Principal Engineer, Water Treatment, Engineering. Future Design Standard changes, if any, will be issued to registered Design Standard users as and when published.

### Head of Engineering

*This document is prepared without the assumption of a duty of care by the Water Corporation. The document is not intended to be nor should it be relied on as a substitute for professional engineering design expertise or any other professional advice.*

*Users should use and reference the current version of this document.*

© Copyright – Water Corporation: This standard and software is copyright. With the exception of use permitted by the Copyright Act 1968, no part may be reproduced without the written permission of the Water Corporation.

## DISCLAIMER

Water Corporation accepts no liability for any loss or damage that arises from anything in the Standards/Specifications including any loss or damage that may arise due to the errors and omissions of any person. Any person or entity which relies upon the Standards/Specifications from the Water Corporation website does so at their own risk and without any right of recourse to the Water Corporation, including, but not limited to, using the Standards/Specification for works other than for or on behalf of the Water Corporation.

The Water Corporation shall not be responsible, nor liable, to any person or entity for any loss or damage suffered as a consequence of the unlawful use of, or reference to, the Standards/Specifications, including but not limited to the use of any part of the Standards/Specification without first obtaining prior express written permission from the CEO of the Water Corporation.

Any interpretation of anything in the Standards/Specifications that deviates from specific Water Corporation Project requirements must be referred to, and resolved by, reference to and for determination by the Water Corporation's project manager and/or designer for that particular Project.

**REVISION STATUS**

The revision status of this standard is shown section by section below:

REVISION STATUS						
SECT.	VER./REV.	DATE	PAGES REVISED	REVISION DESCRIPTION (Section, Clause, Sub-Clause)	RVWD.	APRV.
1	1/0	20.12.14	All	New Standard	ST	NH
	1/1	30.05.20	All	Equilibrium curve added. Stds updated. Tanking working volume and tank design capacity defined.	NH	DH
	1/2	2/09/20	11	1.3: updated to remove use of EPDM	NH	DH
	1/3	21.08.23	16,17	1.7 – minor updates of Standards and Legislation lists. 1.9: minor revision of Abbreviations list	NH	BM
2	1/0	20.12.14	All	New Standard	ST	NH
	1/1	30.05.20	All	Vestibule/viewing room requirement modified. Accessibility section added.	NH	DH
	1/3	21.08.23	20-23	2.5: max temp rise requirement added 2.7, 2.9 & 2.10: more detailed requirements added	NH	BM
	1/4	21.05.24	19	S2.9: Clarifications concerning gridmesh location, height and sumps stairs. Footnote 8 added.	NH	BM
3	1/0	20.12.14	All	New Standard	ST	NH
	1/1	30.05.20	All	Waste holding tank requirements amended.	NH	DH
	1/3	21.08.23	25-28	3.3 & 3.5: more detailed requirements added	NH	BM
4	1/0	20.12.14	All	New Standard	ST	NH
	1/1	30.05.20	26	4.1: requirements clarified.	NH	DH
	1/3	21.08.23	30-33	4.3 More detailed requirements added	NH	BM
5	1/0	20.12.14	All	New Standard	ST	NH
	1/1	30.05.20	All	Major change to 5.1.2 Materials. Further requirements added to 5.2.1.	NH	DH
	1/3	21.08.23	37-38	5.1.3: more detailed requirements added. 5.2.1: Alternative of radar level sensor added.	NH	BM
	1/4	21.05.24	32	5.2.1: Clarification added regarding the use of ultrasonic	NH	BM

REVISION STATUS						
SECT.	VER./REV.	DATE	PAGES REVISED	REVISION DESCRIPTION (Section, Clause, Sub-Clause)	RVWD.	APRV.
				transmitters for use on tanks less than 2m in height.		

6	1/0	20.12.14	All	New Standard	ST	NH
	1/1	30.05.20	All	Material requirements changed in 6.3.6. Chemical barrier protection requirements revised in 6.4.2.	NH	DH
	1/3	21.08.23	45-49	6.3.2: minor clarifications 6.3.3: revised terminology and red tags 6.3.9: revised terminology 6.4.3: Calgon clarifications.	NH	BM
	1/4	21.05.24	41-42	<b>S6.4.2: Preference to include dosing points above ground added, as well as barrier protection reminder.</b> <b>S6.4.3: Potential to not include PCVs added.</b>	NH	BM

7	1/0	20.12.14	All	New Standard	ST	NH
	1/1	30.05.20	45	Minor reference change.	NH	DH

8	1/0	20.12.14	All	New Standard	ST	NH
	1/1	30.05.20	All	Pipe material property information expanded in S8.1 and solvent cement information restructured in S8.4.	NH	DH
	1/2	2/09/20	48	S8.9 and 8.10 updated to remove use of EPDM	NH	DH
	1/3	21.08.23	53-54	8.4: minor clarifications. 8.6: PVC hose preferred, not PE tube.	NH	BM

9	1/0	20.12.14	All	New Standard	ST	NH
	1/1	30.05.20	49	Hydraulic design requirements emphasized.	NH	DH
	1/3	21.08.23	56-57	9.2: Additional requirements concerning potable water supply added.	NH	BM

10	1/0	20.12.14	All	New Standard	ST	NH
	1/1	30.05.20	All	Load-in control requirements clarified.	NH	DH

11	1/0	20.12.14	All	New Standard	ST	NH
	1/1	30.05.20	53	Conductivity alarm set-point amended.	NH	DH

**Design Standard DS 73-01**

**Bulk Sodium Hypochlorite Storage and Dosing System- Basis of Design**

<b>12</b>	<b>1/0</b>	<b>20.12.14</b>	<b>All</b>	<b>New Standard</b>	<b>ST</b>	<b>NH</b>
	<b>1/1</b>	<b>30.05.20</b>	<b>54</b>	<b>Reference updated.</b>	<b>NH</b>	<b>DH</b>
<b>13</b>	<b>1/0</b>	<b>20.12.14</b>	<b>All</b>	<b>New Standard</b>	<b>ST</b>	<b>NH</b>
<b>14</b>	<b>1/0</b>	<b>11.04.14</b>	<b>All</b>	<b>New Standard</b>	<b>ST</b>	<b>NH</b>
	<b>1/3</b>	<b>21.08.23</b>		<b>Equipment Schedule appendices consolidated into one.</b>	<b>NH</b>	<b>BM</b>
<b>15</b>	<b>1/0</b>	<b>20.12.14</b>	<b>All</b>	<b>New Standard</b>	<b>ST</b>	<b>NH</b>
	<b>1/3</b>	<b>21.08.23</b>		<b>Former section 16 renumbered as 15.</b>	<b>NH</b>	<b>BM</b>

# DESIGN STANDARD DS 73-01

## Bulk Sodium Hypochlorite Storage and Dosing System – Basis of Design

### CONTENTS

<i>Section</i>		<i>Page</i>
<b>1</b>	<b>INTRODUCTION.....</b>	<b>10</b>
<b>1.1</b>	<b>Purpose.....</b>	<b>10</b>
<b>1.2</b>	<b>Scope.....</b>	<b>10</b>
<b>1.3</b>	<b>Background Information.....</b>	<b>10</b>
<b>1.4</b>	<b>Related Drawings .....</b>	<b>12</b>
<b>1.5</b>	<b>Water Corporation’s Level of Service (LOS).....</b>	<b>12</b>
<b>1.6</b>	<b>Standard Design Philosophy .....</b>	<b>12</b>
1.6.1	Continuity of Dosing.....	12
1.6.2	Storage Tanks Configuration .....	12
1.6.3	Dosing Panels Configuration .....	13
<b>1.7</b>	<b>Standards .....</b>	<b>14</b>
1.7.1	Australian & International Standards.....	14
1.7.2	Water Corporation Standards.....	15
1.7.3	Acts and Regulations .....	15
<b>1.8</b>	<b>References.....</b>	<b>16</b>
<b>1.9</b>	<b>Terminology &amp; Abbreviations .....</b>	<b>16</b>
<b>2</b>	<b>CHEMICAL BUILDING .....</b>	<b>17</b>
<b>2.1</b>	<b>General.....</b>	<b>17</b>
<b>2.2</b>	<b>Layout and Design .....</b>	<b>17</b>
<b>2.3</b>	<b>Materials of Construction.....</b>	<b>18</b>
<b>2.4</b>	<b>Lighting.....</b>	<b>18</b>
<b>2.5</b>	<b>Ventilation.....</b>	<b>18</b>
<b>2.6</b>	<b>PPE and First Aid Storage .....</b>	<b>19</b>
<b>2.7</b>	<b>Personnel Doors.....</b>	<b>19</b>
<b>2.8</b>	<b>Door to Load-In Panel .....</b>	<b>19</b>
<b>2.9</b>	<b>Platforms and Stairways .....</b>	<b>20</b>
<b>2.10</b>	<b>Accessibility .....</b>	<b>21</b>
<b>3</b>	<b>CHEMICAL STORAGE BUNDING.....</b>	<b>22</b>
<b>3.1</b>	<b>Bund Volume and Geometry.....</b>	<b>22</b>
<b>3.2</b>	<b>Bund Linings and Coating .....</b>	<b>22</b>
<b>3.3</b>	<b>Bund Sump &amp; Valves.....</b>	<b>23</b>
<b>3.4</b>	<b>Bund Sump Instruments .....</b>	<b>24</b>

3.4.1	High Level Switch .....	24
3.4.2	Conductivity Sensor .....	24
<b>3.5</b>	<b>Waste Holding Tank .....</b>	<b>25</b>
<b>4</b>	<b>DELIVERY REQUIREMENTS .....</b>	<b>26</b>
<b>4.1</b>	<b>Delivery Sizes .....</b>	<b>26</b>
<b>4.2</b>	<b>Load-in Apron and Sump .....</b>	<b>26</b>
<b>4.3</b>	<b>Load-in Panel and Transfer Point .....</b>	<b>27</b>
<b>5</b>	<b>STORAGE SYSTEM .....</b>	<b>30</b>
<b>5.1</b>	<b>Tanks .....</b>	<b>30</b>
5.1.1	Tank Number and Sizing .....	30
5.1.2	Tank Materials .....	30
5.1.3	Sodium Hypochlorite Storage Tank Design .....	30
5.1.4	Tank Plinth .....	32
<b>5.2</b>	<b>Tank Instrumentation .....</b>	<b>32</b>
5.2.1	Tank Level (Pressure) Transmitter (LIT82115/LIT82125) .....	32
5.2.2	Tank Magnetic Coupled Level Gauge (LG82134/LG82144) .....	33
<b>5.3</b>	<b>Storage System Pipework .....</b>	<b>34</b>
5.3.1	Filling Line .....	34
5.3.2	Vent Line .....	34
5.3.3	Scour Line .....	35
5.3.4	Process Line .....	35
5.3.5	Overflow Line .....	36
5.3.6	Gas Purge Return Line .....	36
<b>6</b>	<b>DOSING SYSTEM .....</b>	<b>37</b>
<b>6.1</b>	<b>General Considerations .....</b>	<b>37</b>
<b>6.2</b>	<b>Materials of Construction .....</b>	<b>37</b>
<b>6.3</b>	<b>Dosing Panels .....</b>	<b>37</b>
6.3.1	Calibration Tubes (CC82207/CC82307) and Pump Suction Piping .....	38
6.3.2	Sodium Hypochlorite Dosing Pumps (PU82210/PU82310) .....	38
6.3.3	Pressure Safety (Relief) Valves (VA82204/VA82304) .....	39
6.3.4	Strainers (ST82203/ST82303) .....	40
6.3.5	Pulsation Dampeners (PD82216/PD82316) .....	40
6.3.6	Pressure Gauges (PI82218/PI82318) .....	40
6.3.7	De-Gassing Valves (VA82221/VA82321) .....	40
6.3.8	Magnetic Flow Meters (FIT82224/FIT82324) .....	41
6.3.9	Pressure Control (Sustaining) Valves (VA82226/VA82326) .....	41
<b>6.4</b>	<b>Dosing .....</b>	<b>42</b>
6.4.1	Dilution Carrier Water .....	42
6.4.2	Dosing Line .....	42
6.4.3	Dosing Diffusers & Valves .....	43
<b>6.5</b>	<b>Flushing Water System .....</b>	<b>43</b>
<b>6.6</b>	<b>Safety Shower and Eyewash .....</b>	<b>44</b>
<b>7</b>	<b>WATER SAMPLING &amp; ANALYSIS .....</b>	<b>45</b>
<b>7.1</b>	<b>Sampling Point .....</b>	<b>45</b>
<b>7.2</b>	<b>Chlorine Residual Analyser (AIT82419) .....</b>	<b>45</b>
<b>8</b>	<b>PIPEWORK AND VALVES .....</b>	<b>46</b>



8.1	Pipe Materials.....	46
8.2	Pipe Sizes.....	46
8.3	Pipe Fittings.....	46
8.4	Pipework Jointing & Solvent Cements .....	46
8.5	Pipework Supports.....	47
8.6	Hoses and Tubings .....	47
8.7	Pipework Identification and Labelling.....	47
8.8	Pipework Testing.....	47
8.9	Valves .....	47
8.10	Flanges & Gaskets.....	48
8.11	Fasteners .....	48
9	ANCILLARIES.....	49
9.1	Wash Trough.....	49
9.2	Safety Showers & Eyewash Units .....	49
9.2.1	Number and Location.....	49
9.2.2	Safety Shower Water Supply .....	49
9.3	Hose Reels .....	49
10	PROCESS CONTROL.....	50
10.1	Control Philosophy .....	50
10.2	Control Location .....	51
10.3	Load-in Control.....	51
10.4	Tank Level Alarms.....	51
11	LEAK DETECTION AND DECONTAMINATION.....	53
11.1	Sodium Hypochlorite Leak Detection within the Bund .....	53
11.2	Decontamination .....	53
11.2.1	Spills within the Bund.....	53
11.2.2	Dosing Pump, Magflow Meter and Piping Decontamination .....	53
12	PLACARDING, LABELLING AND SAFETY SIGNAGE .....	54
13	APPENDIX A: SODIUM HYPOCHLORITE PROPERTIES AND SAFE HANDLING REQUIREMENTS .....	55
14	APPENDIX B: Sodium Hypochlorite Standard Design - Equipment schedule .....	57
16	APPENDIX C: COMMISSIONING PLAN ITEMS.....	58

# 1 INTRODUCTION

## 1.1 Purpose

The purpose of this document is to explain the reasoning behind the Water Corporation’s design and installation requirements for its bulk Sodium Hypochlorite Storage and Dosing facilities and to provide specific information relating to the Corporation’s preferences and best practices that have evolved over years of experience.

## 1.2 Scope

This document is primarily intended for Sodium Hypochlorite Storage and Dosing facilities that are used for drinking water disinfection although most of it is also relevant to sodium hypochlorite facilities for wastewater treatment or other treatment purposes. It is particularly applicable to sodium hypochlorite plants that have permanent storage tanks that receive supply of bulk sodium hypochlorite delivered in trucks or tankers. For dosing design downstream of dosing panel including dosing spears, mixing of chemical, and dilution/carrier water of chemical, reference should be made to DS78 Chemical Dosing design standard.

## 1.3 Background Information

Sodium hypochlorite (NaOCl) in liquid form, often referred to as liquid bleach, is mainly used in water treatment as an alternative disinfectant to chlorine. Although chlorine gas is highly effective as a disinfecting agent and relatively inexpensive, it has some important inherent risks. Safety concerns associated with the potential for gas leaks makes chlorine gas unsuitable for sites where there is insufficient separation to residential and public access areas. Sodium hypochlorite aqueous solution being less hazardous and easier to handle, is a viable alternative to gaseous chlorine.

Sodium hypochlorite is supplied to Water Corporation facilities as 12.5% to 13.5% (weight/volume available chlorine) concentration solution with a specific gravity of 1.18 at 20°C. The weight/volume (w/v) percent, also termed as trade percent available chlorine, is equivalent to grams of available chlorine per 100mL of solution.

Sodium hypochlorite disassociates in water to form sodium hypochlorite ions (OCl<sup>-</sup>) and Hypochlorous acid (HOCl) according to the following equations:

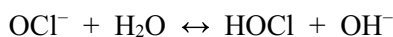

The sodium hypochlorite ion (OCl<sup>-</sup>) exists in equilibrium with the Hypochlorous acid (HOCl) and the relative concentration of these two disinfectant species depends on the pH.

Figure 1-1 illustrates this equilibrium. Hypochlorous acid is the stronger disinfecting species. The equilibrium favours hypochlorous acid at pH less than 7.5.

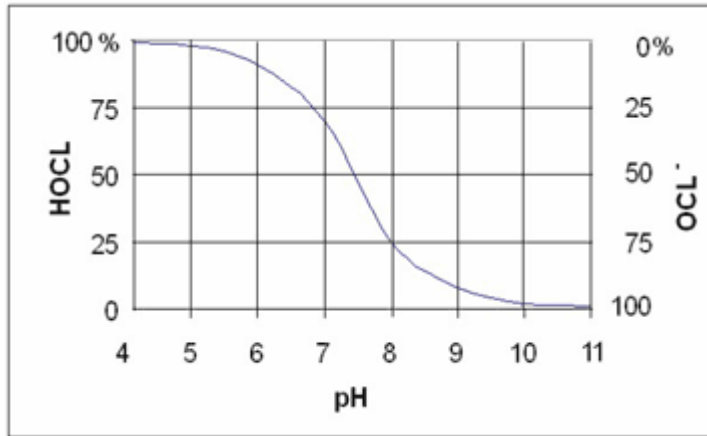

**Figure 1-1: Variation of Hypochlorous Acid (HOCl) with pH.**

Sodium hypochlorite is not without its problems. It is highly corrosive to people and metals, and oxidises many plastics and elastomers. It is relatively unstable and has the potential to crystallize in delivery lines, form scale on the water system components that it comes into contact with, and gasify to the point of exploding piping and valves. These problems may be mitigated by good engineering design and correct material selection. Sodium hypochlorite degrades over time reducing the available chlorine content and producing undesirable byproducts such as sodium chloride, sodium chlorate and oxygen. Factors that influence the rate of sodium hypochlorite degradation include its solution strength, pH, temperature, exposure to UV light, contaminants in its solution and contact with certain metals.

Material selection for sodium hypochlorite service is critically important. For piping and valves, typically plastics such as uPVC (alternative is ECTFE) are used. Gaskets, o-rings and elastomeric seals shall be made of FPM (also known as FKM and Viton®). Water Corporation no longer permits the use of peroxide cured EPDM due to past instances of sulphur cured EPDM being inadvertently used and then subsequently failing causing leaks.

Another factor that complicates material selection is that some metals offer good corrosion resistance but cause accelerated decomposition of sodium hypochlorite. When sodium hypochlorite decomposes it produces oxygen gas which can cause significant problems with vapour locking of dosing pumps or achieving consistent control with dosing systems. Experience has shown that a seemingly minor detail, such as the wrong metal spring in a pressure sustaining valve or dosing pump check valve, can result in a dosing system failure. Direct exposure to stainless steels, duplex stainless steels and Hastelloy results in rapid decomposition of sodium hypochlorite solution and causes equipment failure.

Sodium hypochlorite solutions will react vigorously with most acids to release toxic chlorine gas. In general, sodium hypochlorite must not be mixed with other chemicals, and other organic compounds, including oils, fuels and grease unless it is known that they are compatible.

## 1.4 Related Drawings

The Piping and Instrumentation Diagrams (P&IDs) and the General Arrangements associated with this Basis of Design document can be found in the Corporation’s Drawing Management System (DMS) and have the following drawing numbers:

P&IDs	JD71-060-082-01 through to JD71-060-082-04
General Arrangement drawings	JD71-070-082-01 through to JD71-070-082-08.

## 1.5 Water Corporation’s Level of Service (LOS)

Two separate designs for two levels of service (High LOS and Low LOS) were initially suggested for the sodium hypochlorite dosing design standard. A low LOS design standard that was less complex and which could be built at a lower cost was proposed for re-chlorination facilities. However, this is now thought to pose a potential risk of delivering low chlorine residual to consumers in the event when upstream primary chlorination failed. Provision of a high Level of Service (LOS) to all sodium hypochlorite sites is therefore essential if frequent interruption to the chlorination process is to be avoided.

## 1.6 Standard Design Philosophy

### 1.6.1 Continuity of Dosing

Disinfection treatment process is critical and mandatory to the production of safe drinking water. Provision of duty and standby dosing systems is therefore essential if frequent interruption to the chlorination process is to be avoided.

For primary disinfection site, a failure of the sodium hypochlorite dosing system shall initiate automatic stoppage of flow in the water main being dosed.

### 1.6.2 Storage Tanks Configuration

At least two (2) tanks shall be provided for storing sodium hypochlorite. Chemical storage tanks in a treatment facility are usually operated in a separate duty and standby configuration to improve reliability and flexibility. Operational experience with sodium hypochlorite however indicates that the best sodium hypochlorite storage tanks setup is an inter-connected two tanks system with the valves on the cross-connection normally kept open. The rationale behind the open cross-connection configuration is summarised as follows<sup>1</sup>:

#### a) Delivery of Hypo

The inter-connected tanks configuration with the valves “normally open” would only require a single fill point into both tanks instead of two separate fill points as in the case of non-connected tanks or tanks with “normally closed” cross-connection. The single fill point eliminates risk of wrongly filling the duty tank instead of the empty one, and in the process overflowing it as well.

#### b) Reordering of Hypo

“Normally open” cross-connection requires less rigorous monitoring of sodium hypochlorite levels and less frequent ordering and delivery of hypo. It provides a larger filling capacity allowing better leeway for unreliability of tanker delivery and for non-delivery on weekends and public holidays.

#### c) Sodium Hypochlorite Strength

“Normally open” cross-connection provides frequent turnover of sodium hypochlorite in the tanks simultaneously and therefore avoids the higher sodium hypochlorite strength deterioration that will

<sup>1</sup> Refer to [Nexus ID#47204777 -Discussion Paper on Cross Connection of Tanks](#)

occur in a standby tank if the tanks are not cross connected. With the “averaging” of sodium hypochlorite strength in two tanks, it offers better dosing control, thereby reducing the risk of water quality violation.

d) Operation and Control

“Normally open” cross-connection avoids unnecessary operational and control complexity. There is less operational effort, costs and risk as there is no need to operate valves and control associated with changing over of duty tank.

e) Bund Size

Extra cost for the larger bund size to hold 2 tanks capacity instead of one is generally minimal especially for smaller size tanks (less than 10,000L with bund height of 800mm) as tan theta rule of AS3780 tends to dominate sizing calculation.

Even though the tanks are inter-connected in the setup, a two tanks system will still ensure an uninterrupted supply of sodium hypochlorite in the event when one of the tanks is taken offline due to failure or maintenance. By closing a valve in the cross-connection, the system can continue normal dosing from the other tank.

### 1.6.3 Dosing Panels Configuration

To ensure a high Level of Service, separate duty and standby dosing systems downstream of the storage tanks are provided in two separate dosing panel enclosures<sup>2</sup>.

This allows maintenance to be safely done on one dosing system, while the other dosing system is in operation, safely sealed in a separate dosing enclosure. This approach to design achieves both occupational safety objectives and continuity of dosing objective of the Water Corporation.

---

<sup>2</sup> One dosing panel with duty and standby dosing pumps may only be approved if the system is non-critical because it can be readily shut down for maintenance – e.g. it is an intermittent operation or maintenance downtime is acceptable because of large drinking water storage or other reasons.

## 1.7 Standards

This design standard refers (directly or indirectly) to the following standards and regulations:

### 1.7.1 Australian & International Standards

AS 1111.1	ISO metric hexagon bolts and screws – Product grade C – Bolts
AS 1112.3	ISO metric hexagon nuts – Product grade C
AS 1214	Hot-dip galvanized coatings on threaded fasteners (ISO metric coarse thread series)
AS/NZS 1170.1	Structural design actions – Permanent, imposed and other actions
AS 1158.3.1	Lighting for roads and public spaces – Pedestrian area (Category P) lighting – Performance and design requirements
AS 1318	SAA Industrial safety colour code
AS 1319	Safety signs for the occupational environment
AS 1345	Identification of the contents of pipes, conduits and ducts
AS 1657	Fixed platforms, walkways, stairways and ladders – Design, construction and installation
AS 1680.2.4	Interior Lighting – Industrial tasks and processes
AS 1688.2	The use of ventilation and air-conditioning in buildings – Part 2: Ventilation design for indoor air contaminant control (2002)
AS 2032	Installation of PVC pipe systems
AS 2293.1	Emergency escape lighting and exit signs for buildings – System design, installation and operation
AS 2634	Chemical plant equipment made from glass fibre reinforced plastics (GRP) based on thermosetting resins
AS 3500	National plumbing and drainage code (provision of backflow prevention devices)
AS 3780	The storage & handling of corrosive substances
AS 3879	Solvent cements and priming fluids for PVC (PVC-U and PVC-M) and ABS pipes and fittings
AS 3953	Construction of buildings in bushfire-prone areas
AS 4041	Pressure piping
AS/NZS 4087	Metallic flanges for waterworks purposes
AS/NZS 4680	Hot-dip galvanized (zinc) coatings on fabricated ferrous articles
AS 4775	Emergency eyewash & shower equipment
ASME RTP-1	Reinforced Thermoset Plastic Corrosion-Resistant Equipment
BS EN 13121-3	GRP Tanks and Vessels for use above ground. Design and workmanship. (2008 + A1:2010)
BS 4994	Design & Construction of Vessels & Tanks in Reinforced Plastics
DVS 2205	Design Calculations for Containers & Apparatus Made of Thermoplastics
DVS 2207	Welding of Thermoplastics

## 1.7.2 Water Corporation Standards

DS 20	Electrical Design Process
DS 22	Ancillary Plant & Small Pump Stations – Electrical
DS 24	Electrical Drafting
DS 26	Type Specifications - Electrical
DS 27	Regulating Valve Control
DS 28	Water and Wastewater Treatment Plants - Electrical
DS 30	Mechanical General Design Criteria & Glossary
DS 31-01	Pipework
DS 31-02	Valves & Appurtenances
DS 32	Pump stations
DS 33	Water Treatment Mechanical Design Standards
DS 35	Ancillary Plant Mechanical Design Standards
DS 36	Strategic Product Specifications and Product Atlas
DS 40	SCADA Standards
DS 40-06	Software Change Control
DS 40-08	Standard for the Control of Chemical Dosing
DS 40-09	Field Instrumentation
DS 62-01	Site Security Treatments
DS 78	Chemical Dosing Standard
DS 79-01	Design of Chemical Systems - Legislative Requirements and General Principles
DS 79-02	Emergency Safety Showers and Eyewash Stations Standard
DS 79-03	Chemical Barrier Protection
DS 79-04	Chemical Signage, Labelling and Markers
DS 79-05	Small Chemical Dosing Systems
DS 80	WCX CAD Standard
DS81	Process Engineering
DS 95	Standard for the Selection, Preparation, Application, Inspection and Testing of Protective Coatings on Water Corporation Assets
DS 100	Suspended Flooring (Grid Mesh and Chequer Plate)
SPS 498	GRP Chemical Storage Tanks
WS-2	Welding & Joining Specification – Thermoplastics
Strategic Products Register	

## 1.7.3 Acts and Regulations

Dangerous Goods Safety Act 2004 (Western Australia)

Dangerous Goods Safety (Storage and Handling of Non-explosives) Regulations 2007 (Western Australia)

Work Health Safety Act 2020

Work Health Safety (General) Regulations 2022

## 1.8 References

Criteria for Drinking Water Supply, Water Corporation

Australian Drinking Water Guidelines

KWS Investigation Report – Hypo Dosing Faults, Service Reservoir Chlorination and Independent Artesian GWTP, July 2005 to January 2006, P. Hanley, 7 March 2006 (with installation standard drawing and notes Rev 8, 25 August 2008)

Sodium Hypochlorite Bulk Storage Installation Guide, Coogee Chemicals

White's Handbook of Chlorination and Alternative Disinfectants, 5th Edition, Black & Veatch Corporation.

## 1.9 Terminology & Abbreviations

ADWG	Australian Drinking Water Guidelines
Corporation	The Water Corporation
DG Regs	Dangerous Goods Safety (Storage and Handling of Non-explosives) Regulations 2007 (Western Australia)
Hypo	Sodium Hypochlorite
FRP	Fibre Reinforced Plastic
GRP	Glass-fibre Reinforced Plastic
HMI	Human Machine Interface
OIP	Operator Interface Panel
UPVC	Unplasticised Polyvinyl Chloride
WHS	Work Health Safety Regulations 2022
Tank working volume	the volume of the tank between the low-low alarm and the high alarm
Tank design capacity	the volume of the tank from its base to the invert of the overflow
Transfer Point <sup>3</sup>	the point where the filling pipework of a bulk container (e.g. tank) terminates and where the hose from the delivery truck connects during load in (transfer) of chemical into the container.

<sup>3</sup> Transfer point is defined in a broader sense in AS3780 Clause 5.5.7 as “the point where the pipework from a bulk container terminates” and where a vehicle can transfer product into or receiving product from the container.



## 2 CHEMICAL BUILDING

### 2.1 General

The storage and dosing system shall be constructed within a building. The function of the building is:

- a) To shield the stored sodium hypochlorite from heat and UV light, thus minimising its degradation;
- b) To exclude rainfall from the bund, therefore eliminating the need to size the bund with additional capacity for rainwater and for operations to have to manage emptying it and keeping it clean;
- c) To protect the equipment inside from UV degradation;
- d) To provide an additional level of separation of this hazardous chemical from staff and visitors to site; and
- e) To safeguard the assets in line with the Corporation's key security principles<sup>4</sup>.

### 2.2 Layout and Design

The internal layout shall be as uncluttered as possible with all piping to be located either around the periphery of the building, under grid-mesh or attached to the ceiling, to give a tidy arrangement which leaves adequate access to all components for operation and maintenance.

The internal walls of the room shall be designed to minimise the number of protrusions and thereby provide as much flush wall space as possible to facilitate wall mounted equipment, instruments, and simplify the running of piping and cable trays. The piping shall also be appropriately located to allow easy access to equipment and valves, and facilitate unobstructed cleaning of the work areas. Ramps over the drops in floor levels should be included at appropriate locations for easy moving of equipment in and out of the building.

The design and layout of the facility shall include consideration of provisions as laid out in section 9.2.1 of AS 3780. This shall include sufficient space between bund walls, storage areas and other structures that will allow access for maintenance and during emergencies. Specifically for maintenance access, an unobstructed clearance of not less than 1.0 m shall be provided in front of the dosing pump/panel and other equipment, with a minimum 2.1 m head clearance.

The building, inclusive of doors, windows and ventilation openings shall be designed to better withstand bushfire attack in accordance with AS3959.

The building shall also be designed to exclude wildlife, insects and vermin. Measures shall include door seals, tropical midge mesh on ventilation openings, and brush ware around the edges of the roller shutter to impede ingress of insects through the doorway when the roller shutter is in the closed position.

The building shall be designed so that storage tanks can be removed and replaced, by using either removable wall panels, or having a roof specially designed with a lift-out section such that the structure retains integrity when the roof section is removed. For facilities with two or more storage tanks, the design shall allow for replacement of any tank while the others remain in operation.

The general arrangement drawing JD71-070-082-01 gives an overview of the main features of the sodium hypochlorite building.

---

<sup>4</sup> The Guidance Notes for Site Security Treatments, Clause 8.3 provides information on the security principles.

## 2.3 Materials of Construction

Various materials of construction may be appropriate for the sodium hypochlorite room – metal clad, concrete or masonry walls. Choice of building materials will need to consider the corrosive property of sodium hypochlorite, as well as architectural and security requirements that apply to the particular site. Consideration should be given to materials of wall panels, roof and doors including their insulation features and seals to minimise transfer of outdoor heat into the storage and dosing room.

## 2.4 Lighting

Internal lighting, external entry lighting and lighting on internal roads shall be provided, all with easy and safe access for lamp maintenance. These lighting levels and other characteristics shall be designed to conform to the requirements of DS28. Internal lighting shall be on backup power supply (eg. UPS) unless specifically not required in the project User Requirements. The building shall be equipped with internal emergency lighting that has battery backup.

## 2.5 Ventilation

The degradation rate of sodium hypochlorite increases as temperature rises. Studies have shown that for every 10°C increase in storage temperature, the decomposition rate increases by a factor of 3-4 in a solution of 5% to 16% (w/v) sodium hypochlorite<sup>5</sup>. Sodium hypochlorite should therefore preferably be stored in rooms that are kept cool at lower temperature or at least well-ventilated.

Ventilation shall be accomplished in accordance with the Water Corporation’s mechanical standards (refer DS30-02) which references AS1668.2. Natural ventilation is preferred over mechanical ventilation as it does not require redundancy, nor does it incur running costs. However, sodium hypochlorite fumes are considered Type A effluent as defined in AS1668.2 so the minimum requirement, whenever the building is occupied, is natural ventilation combined with mechanical exhaust<sup>6</sup>.

The ventilation system design shall comply with the requirements of AS1668.2 and shall incorporate the following key features:

- a) The temperature rise in the building shall be limited to 6°C above ambient.
- b) The minimum total area of natural ventilation openings shall be the greater of 5% of the floor area and the ventilation area required to achieve item “a)” above.
- c) Openings for natural ventilation should be positioned on opposite sides of the room to maximise cross-draught.
- d) Openings for natural ventilation shall be provided at high and low levels to maximise the benefits of thermal effects.
- e) Velocity of air as it enters the exhaust hood shall be not less than 0.5m/s averaged across the opening.
- f) The exhaust fans shall be located near the floor just above the bund and air shall be discharged vertically at a high level above the building with a discharge velocity not less than 5m/s to prevent further contamination of the storage areas.

The exhaust system shall be activated by an external switch or deactivation of building security. Consideration could be given for the exhaust fans to be controlled by a temperature switch located inside the building so that the fans would automatically operate to cool down the sodium hypochlorite storage tank area when a temperature set-point is reached.

<sup>5</sup> White’s Handbook of Chlorination and Alternative Disinfectants, 5th Edition, Black & Veatch Corporation.

<sup>6</sup> AS1668.2-2012 Cl .3.3 defines a Type A effluent & Figure 3.1 provides general guide for the application of exhaust systems.

At sites where ambient temperature is normally high, the use of air-conditioning may be considered to significantly reduce sodium hypochlorite degradation. However, this will have to be considered with cost analysis on a project by project basis.

## 2.6 PPE and First Aid Storage

The sodium hypochlorite dosing facility shall include generous room to store the PPE and first aid equipment that is required for use in the dosing room. This space may be provided in a room such as a control room or switch room, but, it shall be in close proximity to the dosing room to facilitate ready access to PPE by personnel.

If a room is provided adjacent to the hypochlorite storage and dosing room, then that room shall incorporate a door between the rooms and a large PVC<sup>7</sup> viewing window that allows the Operator to view the sodium hypochlorite storage and dosing room (particularly the dosing panels).

## 2.7 Personnel Doors

The location of access doors to the room shall be selected to maintain the required separation and segregation distances outlined in the Western Australian Dangerous Goods Safety Act 2004 and its associated regulations and AS780. Consideration should be given to the potential inclusion of exit only doors where personnel undertaking activities may not be able to access the usual route of entry/exit. If the floor area is greater than 25m<sup>2</sup> then two means of access are required. Consideration should be given to the potential inclusion of exit only doors where personnel undertaking activities in the storage and dosing room may not be able to access the usual route of entry/exit.

All personnel doors into the main storage area shall open outwards. The travel path of the door shall not be restricted by external features on the building or any other structure.

Any internal door into the storage tank area shall be fitted with a PVC window in the top section to allow visibility prior to opening. If the room layout warrants it, a one-way door from the chemical storage area to outside of the building may be required specifically as an emergency exit. Access through this door shall be possible from inside the FSA storage room only, no handle is to be provided on the outside and it shall be signed appropriately. Refer to section 12 for appropriate signage.

Personnel doors shall be designed to meet the required fire rating and shall be fitted with crash-bars for use as emergency exits. They shall open outwards and the travel path of the doors shall not be restricted by external features on the building or any other structure. External doors shall be metal-faced to provide weather resistance but insulated at the same time to prevent heat transmission into the Hypo storage room. They shall have pull handles and retaining hooks for holding in the open position. Hydraulic operated door anti-slam closer/damper shall be provided for each door leaf. Appropriate signs shall be fitted on the doors.

## 2.8 Door to Load-In Panel

Door access shall be provided for the chemical delivery driver to gain access to the load-in panel located just inside the sodium hypochlorite building. The doorway width shall be sufficient (2.5m minimum) to allow movement of equipment into and out of the storage/dosing room.

Single curtain sheet roller doors that have been commonly used as the access door to chemical load-in panels are not suited for sodium hypochlorite storage area as they transmit a considerable amount of undesirable heat into the storage room in hot weather condition thereby accelerating the degradation of the stored sodium hypochlorite. Roller doors shall have thermal insulation core to minimize heat transfer

---

<sup>7</sup> PVC is recommended for its chemical resistance and durability. Glass shall not be used as it will eventually turn opaque with continuous exposure to caustic vapour from the hypochlorite.

into the chemical storage area. The operation of these doors shall be automated using heavy duty motors and they shall be equipped with manual override. These doors shall be industrial strength with galvanised fixtures and guides. If hinged doors are to be provided for load-in panel access, they shall be supplied and installed as for personnel doors.

Opening of the door to the load-in panel during a sodium hypochlorite delivery shall automatically initiate the 3-way apron sump drain valve VA82105 to open to the waste holding tank (and close to drainage) in anticipation of any potential spillage. Closing the door after the delivery will revert the 3-way drain valve back to the normal condition of directing rainwater from the apron sump to stormwater drainage.

## 2.9 Platforms and Stairways

An FRP gridmesh platform is to be provided over the bund to give access around the tank if there are any valves that require operation. Cut-out sections with removable covers shall be provided to allow easy access for likely operational activities (e.g. to allow removal of valves, neutralisation activities, etc.) and to comply with DS100 (s3.5.2 is particularly relevant).

Sufficient gridmesh area is required to accommodate the load-in and dosing panels and associated equipment, including maintenance access. The height of the platform is to suit the height of the load-in connection (refer to section 4.3 for further detail) but shall be above the flood level of the bund. The platform shall be designed in accordance with DS30-02, DS100, AS1170.1 and AS1657 plus shall have the necessary kickplate and handrails. All structural components of the floor, stairs and handrail system shall also be FRP.

There shall be a stairway from the platform down to the bund floor for access to the bund sump<sup>8</sup>. All stairways shall be equipped with automatic self-closing gates. Stairs and platforms shall be sized to accommodate the movement of personnel wearing SCBA sets and carrying neutralisation spill kits.

The FRP grating selected for the platform shall:

- a) Be resistant to sodium hypochlorite;
- b) Be moulded type with square mesh pattern to provide bi-directional strength;
- c) Have a non-slip grit top surface;
- d) Have a layout which enables access to pipework, valves and equipment by incorporating readily removable sections;
- e) Be fastened in place using 316 SS clips to prevent sliding and overturning; and
- f) Have any shop or field cuts coated with resin to provide maximum corrosion resistance.

Various grades of FRP grating are available, so it is important to ensure that the FRP grating selected and supplied for the sodium hypochlorite storage room is chemical resistant and more specifically, suitable for sodium hypochlorite applications. As each manufacturer has its own means of designating grating types and grades (e.g. colour identification), suitability of a proposed FRP grating will need to be confirmed with the respective FRP manufacturer.

The design should minimise the number of valve spindles to be extended above grating level and instead provide cut-outs to allow use of a tool to operate below the grating valves (operators shall not be required to kneel and/or extend their hands below grating level. **Cut-outs shall not create a tripping hazard or obstruct access/egress ways.** Where cut outs are required in the FRP grating, for access to equipment such as valve spindles or for intersection of pipework, proper strengthening and support of the modified grating shall be carried out by qualified designers and installers to ensure its integrity is not undermined.

---

<sup>8</sup> For transportable modules, approval may be sought from the Senior Principal Engineer, Water Treatment to replace this requirement with provision of a removable FRP section above the sump. The design of the removable section shall require the approval of the Senior Principal Engineer, Water Treatment.

The open hole in the grating as the result of the cut out shall be covered with a removable cut-to-shape FRP grating panel securely supported and clipped. All modification work to the grating shall comply with the prevalent WHS requirements for safe access of Grid Mesh Landings.

Equipment and valve spindle end shall not protrude out of the FRP grating where it could pose as a tripping hazard.

The design of the FRP platform supports shall:

- a) Meet the design loading requirements ;
- b) Allow for access to pipework and equipment;
- c) Take into account the direction of fall across bund floor; and
- d) Keep the number of concrete embedment's to a minimum.

Structural FRP members shall be secured to the concrete floors and walls using 316 SS chemical anchor bolts. The concrete to baseplate interface shall be grouted (30mm nominal) to prevent liquids and debris collecting underneath. Unless chemically resistant to sodium hypochlorite, the grout shall be coated to the same standard as the bund.

## 2.10 Accessibility

A minimum clearance of 1m shall be provided around all sides of equipment that require maintenance access, with consideration given to a greater clearance where maintenance activities require it.

All valves, pumps, ancillary equipment, and instruments shall be accessible without having to enter the bund and located above bund wall height. This requirement has an additional benefit of allowing the bund integrity to be tested through filling of the bund to wall height.

### 3 CHEMICAL STORAGE BUNDING

A bund, designed and constructed in accordance with the Dangerous Goods Safety (Storage and Handling of Non-explosives) Regulations 2007 and AS3780, shall extend beneath the storage tank, the load-in panel and all dosing equipment. There shall be no penetrations through the bund wall or floor, other than the drain pipework for the bund sump. The bund shall be separated from protected places in accordance with the DG Regs and AS3780. No incompatible dangerous goods shall be kept within the same bund as sodium hypochlorite.

#### 3.1 Bund Volume and Geometry

For sodium hypochlorite facilities with two inter-connected storage tanks, the bund volume shall be at least 110% of the total design capacity of both tanks in the bund (not to be confused with the working volume capacity). This calculated volume is the net available containment capacity and shall not include the volume occupied by foundations and other items within the bund.

The bund wall height and position relative to the sodium hypochlorite storage tanks shall be such that:

- a) The bund wall is at least 1000 mm from the storage tank to allow for clear access; and
- b) The top inside edge of the bund wall lies outside the tank crest locus limit boundary made up of imaginary lines drawn from the tank crest at 26.5 degrees angle to the vertical (equivalent to a vertical fall of 2 metres for every one horizontal metre from the tank crest). This is to prevent liquid squirting over and outside the bund wall.

The above bund design requirements have been taken from AS3780 (Clause 5.4) which are specific with regards to chemical storage bund design.

The minimum separation distance between the tanks is 1000mm unless approved otherwise (AS3780 Clause 5.3.2.2 mandates 600mm);

The bund floor shall have a minimum slope of 1 in 50 falling towards the sump. Note that this grade has been deliberately selected to be greater than typical tolerances for unformed surfaces to avoid ponding. As sodium hypochlorite is slippery when spilt, ponding is a major slip hazard and therefore undesirable in storage and dosing rooms.

Note: For transportable modules, a minimum slope of 5 in 1000 (1 in 200) is acceptable due to the floor areas being smaller in size.

<b>Commissioning Plan Information</b>
---------------------------------------

As part of construction quality assurance or Factory Acceptance (in the case of modules), the slope shall be checked to confirm that requirements have been satisfied. A test shall be conducted for effective drainage and absence of ponding.
---

#### 3.2 Bund Linings and Coating

A coating that is resistant to sodium hypochlorite shall be provided for the bund. The bund floor, sump, walls (and building walls where these are within the crest locus limit of the tank) and tank plinths shall be coated. The grouting at the interface between supports or equipment shall also be coated to the same standard as the rest of the bund. The floor coating system shall incorporate a non-slip finish.

Coatings for concrete bunds shall comply with Water Corporation Coating Specification CR5. To achieve effective water-tight sealing of the bund, proper application of coatings is essential especially around pipes and fittings which pass through the bund wall or floor. Strict specifications for products to be used and the methods of application should be in place to ensure that this is achieved.

Commissioning Plan Information
A 24 hour hydrostatic leak test shall be conducted on a bund prior to the filling of its associated storage tank(s) with chemical.

Water that has been used for the hydrostatic test on the storage tanks can be discharged onto the bund for use in its' hydrostatic leak test.

### 3.3 Bund Sump & Valves

The sodium hypochlorite bund shall have a wet sump for collection of spills and leaks. Although the toroidal type of conductivity analysers is suited to normally dry operation, a wet sump is required to minimise fume generation and so that the conductivity analyser is able to detect small amounts of chemical leakage (rather than having to accumulate a significant volume in the sump before the liquid level reaches the conductivity analyser) so that an Operator can take action to neutralise the acid before it degrades the bund coating. A float operated water supply valve (VA82151) shall maintain a fixed water level in the sump. As this valve is crucial for the effective functioning of the wet sump, the float operated valve must be of durable high-quality construction. The robust, heavy duty type valve shall have a reliable control mechanism that requires minimal maintenance. Valve components shall be constructed from materials that are corrosion-resistant and suitable for the chemical environment.

The bund sump serves multiple functions:

- a) It collects any spillage or tank overflow where it can then be pumped out or drained away;
- b) It provides a location for detection of high conductivity and/or increase in liquid level in the event of a leak; and
- c) It provides a location for the neutralisation of minor spills.

The sump shall be adequately sized to house all necessary equipment and pipe entries but shall not be smaller than 1200 long x 800 wide x 300 deep. The sump arrangement shall provide adequate volume for neutralisation of the minor leaks and spills and sufficient water depth for operation of the float valve and immersion of the conductivity sensor. Clear access for maintenance of the valves and equipment located in and adjacent to the sump shall also be provided.

A DN50 PVC drain outlet pipe positioned flush with the floor of the bund sump shall lead to an exterior valve pit outside the sodium hypochlorite building where a DN50 manually actuated valve (VA82103) and a DN50 actuated 3-way valve (VA82106) are located. The valve pit shall be sized to enable easy access for the installation and maintenance of these valves. The electrically-actuated valve VA82106 shall be operated from the OIP, and shall be interlocked with the bund sump conductivity reading to prevent inadvertent discharge of sodium hypochlorite from the bund. An override switch will be available locally near the valve pit and from the OIP to allow this interlock to be overridden by the operator on site, once they have confirmed that the contents of the sump are safe for disposal to the soakwell/site drainage. However, to prevent accidental release of bund sump contents, the actuated valve shall be programmed to automatically close if it is left open for longer than 30 minutes continuously, whether override is selected or not. When there is a valve fault, VA82106 shall also automatically close (i.e. fail-safe).

The manual isolation valve VA82103 is an additional protection measure against accidental discharge and allows isolation of the three-way valve for maintenance.

The exterior valve pit shall have a removable cover, allowing ready access to the valves inside. The isolation valve VA82103 shall be supplied with securely-supported extension spindle and handle located just below the cover to allow manual operation without sump entry. The valve tag numbers along with each open and close position shall be clearly marked on each valve. A simple and concise description outlining the purpose of each valve shall also be mounted on a small sign adjacent to each handle to assist with correct valve identification and operation. Any rain water collected in the valve pit shall be directed to a soak well or drainage.

Any rainwater collected in this external sump will be directed to the load-in apron sump by a DN100 PVC drain line. An additional collection chamber, sump pump and delivery line shall be provided if gravity flow to the waste holding tank and soak well/site drainage system cannot be achieved. This system can be common with other compatible chemical bund sump drains.

## 3.4 Bund Sump Instruments

The following instruments will be installed in the bund sump to assist the operators with the identification of possible sodium hypochlorite leaks.

### 3.4.1 High Level Switch

A high level float switch (LSH82152) shall be fitted to detect a high fluid level in the bund sump and is used to generate a high bund sump level alarm. This switch shall be linked to the plant control system to alert of a sodium hypochlorite or water spillage. The level switch shall be set to activate an alarm at the lowest practical level in the sump.

The float and cable insulation shall be fabricated from chemical resistant components. The junction box shall be mounted on the wall or the grating platform, above the bund height, so that it can be easily accessed for maintenance without having to reach across the sump.

### 3.4.2 Conductivity Sensor

The bund sump shall have a toroidal type conductivity probe (AE82153) to detect leakage of a highly conductive solution (sodium hypochlorite solution) as opposed to water. High conductivity shall generate an alarm in the plant control system and close the sump drain valve VA82106 or prevent it from opening. If the high level alarm in the sump is registered at the same time with the high conductivity alarm, the sodium hypochlorite tank outlet valves shall be interlocked to close. The dosing system will subsequently shut down and “Water Quality Breached” alarm generated.

Suggested high conductivity alarm setting = 85 mS/cm (approx 0.5% NaOCl).

A conductivity (toroidal) sensor is deemed required over a pH analyser for the detection of sodium hypochlorite spills for the following reasons:

- a) It is considered more robust than pH probes.
- b) They do not normally require calibration.
- c) The toroidal probe has a very long life whereas pH analysers have a high life cycle costs for routine pH probe replacement due to limited probe life (typically 2 years).
- d) It is suited to being maintained in pH neutral solutions the majority of the time
- e) Failure of a pH probe may result in a low pH signal, thus erroneously initiating an alarm indicating a chemical leak.
- f) Failure of a pH probe may also result in a constant pH reading near neutral (pH 7.00). When this occurs, the probe failure is not immediately obvious to the operator and may go unnoticed, thus an actual sodium hypochlorite leak at this time may not be detected.

The conductivity probe, seal and cable shall be fabricated from components suitable for sodium hypochlorite.

The conductivity sensor transmitter shall be mounted on the wall adjacent to the sump above the bund height. It is preferable that it be located so the display can be read without entering the bunded area and so it can be maintained without reaching across the sump.



### 3.5 Waste Holding Tank

A waste holding tank based on drawings FQ18-6-17, 6-24.2 and 6-27 and with a minimum storage capacity of 1000L<sup>9</sup> shall be provided at each site for the collection of sodium hypochlorite spillage and waste. A larger tank should be provided if the tanker pump rate is greater than 7 L/s or where other site-specific considerations or risks exist e.g. location is near a river or other water body. The main purpose of this tank is to stockpile the small quantities of sodium hypochlorite spillage and neutralised waste generated in either the storage room or load-in apron during normal operational duties. When sufficient waste is collected in the tank, a tanker truck can be arranged to pump out and transport the waste off-site for proper disposal. If the waste holding tank is not located close to the load-in apron, road access to the tank shall be provided for the tanker.

The waste holding tank shall be fabricated from a material suitable for the long term storage of waste chemical, such as polyethylene or GRP, as it may be expected to hold waste (undiluted or diluted) for well over a year depending on the waste production volumes. It is normally located below ground or at a level lower than the bund sump and load-in apron sump, so waste can gravitate to this tank. The tank shall be housed within a concrete liner to protect it from ground forces and to allow its easy removal at end of life. Joins in the concrete liner shall be sealed with Sika Tank to ensure that the concrete liner can act as secondary containment if sodium hypochlorite were to leak from the waste holding tank. The design of the tank shall withstand any buoyant forces when empty, particularly if natural groundwater levels can flood the concrete liner.

The tank shall be fitted with a suitable float type level switch (LSH82107) to warn the operator when the waste has reached a high level so they can arrange for disposal. The design shall ensure that the switch can be easily accessed without the use of special equipment (e.g. cranes, scaffolding, etc.). A vent with insect screen shall be provided for the tank.

---

<sup>9</sup> A 1000L tank capacity would be sufficient to contain a load-in chemical spillage volume of 840L calculated from pumping at a rate of 7L/s for two minutes before emergency shutoff. As a side note, requirement of AS3780 Clause 5.8.4.2 for capacity of spillage control system to be the greater of 9000L or largest tanker compartment is only intended for loading of chemical into tankers, not unloading from tankers as is the case at load-in facility. This was clarified by DMP in 2010 (ref Meeting minutes dated 3 June 2010 Nexus ID #53022606).

## 4 DELIVERY REQUIREMENTS

### 4.1 Delivery Sizes

Sodium hypochlorite is typically delivered by road tankers with 12,000L capacity or less. Tanks shall be sized so that delivery volumes can be accommodated in the volume contained between the high level alarm and low level alarm. For smaller sites the deliveries are carried out in “milk runs”. The truck is fitted with its own unloading pump, generator set and flexible hose for unloading the chemical from the tanker. Power is usually not required to be provided at site for unloading.

Where there is a possibility of semi-trailers being used to undertake deliveries, a permanently mounted, external weatherproof electrical power outlet conforming to the following specifications shall be provided for truck mounted pumps:

- a) Power outlet to be located away from the delivery hose connection point (to enable the pump to be safely stopped in the event of a leak during discharge) but within 7.5 metres of the road tanker;
- b) IP56 rated combination switch and 4-pin plug socket for 3-phase, 415 Volts, 50 Hz at 20 Amp rating with earth leakage protection (eg. Clipsal 56 Series);
- c) Equipment rated for starting a 4 kW motor;
- d) Earthing point close to plug outlet and earth leakage protection;
- e) The installation is to be in accordance with AS 3000 and power supply authority regulations including appropriate labelling.

The power outlet shall incorporate a device to cut off the power supply when the storage tank high level alarm is initiated.

Early in the design phase, the designers shall confirm what type of deliveries will be received and design the necessary load-in facilities accordingly.

### 4.2 Load-in Apron and Sump

A 200mm thick reinforced concrete load-in apron with the minimum dimensions of 16m long and 4.5m wide for rigid truck deliveries shall be provided adjacent to the sodium hypochlorite storage room. The load-in apron shall be located nearest to the load-in panel door opening as the length of flexible transfer hose is 4m.<sup>10</sup> The apron shall have a small trafficable lip (less than 100mm high) around the perimeter for the containment of spills.

The apron shall be graded to a sump from where its contents drain to either a soakwell/site stormwater drainage or the waste holding tank via an actuated 3-way valve (VA82105). Under normal conditions, this valve is opened to discharge to the soakwell/site drainage so that rainwater is not collected on the apron. During a sodium hypochlorite delivery, it is part of the tanker truck driver’s procedures to open the door in front of the load-in panel. At sites where the security system is not linked to the sodium hypochlorite load-in system, the opening of this door will automatically initiate the 3-way valve to open to the waste holding tank (and close to site drainage) in anticipation of any potential spillage. At the end of the load-in process, the door to the load-in panel would be closed activating the switch to revert the valve back to its normal state of ‘open to site drainage’ and ‘closed to the waste holding tank’.

The actuated 3-way valve (VA82105) shall have limit switches to indicate valve position on the HMI, OIP and load-in panel displays. It shall have manual override with securely-supported extended spindles all housed in a valve pit with removable cover. In the event of valve failure or power outage, the valve shall automatically open to the waste holding tank and close to site drainage.

<sup>10</sup> As provided by. Coogee Chemicals Pty Ltd “Bulk Storage Installation Guide”. Maximum allowable hose length from AS3780 Cl 5.8.3 (a) is 6m.

The sump shall be fitted with a suitable level switch (LSH82104) to provide warning when the content in the sump has reached a set high level. The sump high level alarm shall be shown on the load-in panel and on the OIP/HMI.

Road access to the load-in apron shall be designed to include a drive through route. If this is not possible, as may be the case on brown field sites, a turning circle with a minimum radius of 12.5m for rigid truck tanker shall be incorporated<sup>11</sup>. This is to enable the sodium hypochlorite delivery truck to be driven clear of the facility without the need to reverse<sup>12</sup>.

A safety shower and eye-wash unit shall be provided at apron level between 2 and 7m from the transfer point, primarily for the use of the delivery driver, and a 600mm wide clear access route to this shower shall be maintained at all times. Any platform or stairs projecting onto the load-in apron shall be designed so that access to the safety shower is not restricted, especially when the truck is parked up for unloading.

### 4.3 Load-in Panel and Transfer Point

The sodium hypochlorite is transferred from the delivery truck into the storage tanks via a transfer connection point on the load-in panel. At the start, and during the load-in operation, the tanker driver is located at his vehicle (away from the connection point) ready to stop the pump operation. The load-in connection shall meet the following requirements:

- a) It is to be located at a safe and ergonomic height for connection and disconnection – 1000mm above floor/platform level where the driver stands to connect the hose is recommended (this may require the inclusion of a platform to achieve this).
- b) It shall be located at least 5m from any protected place or the plant boundary<sup>13</sup>.
- c) It shall be DN50 Polypropylene male NATO camlock coupling with matching dust cover. The camlock coupling must be pre-approved and of reputable make.
- d) It shall be positioned horizontally if the transfer point is not elevated. Where it is elevated<sup>14</sup>, the connection can be at either 90 degrees to the vertical or a slight angle (22.5 degrees below the horizontal) in a downwards direction. This allows free drainage back down the delivery hose once the delivery is completed and because of the slight angle can in some cases eliminate extra hose support. The preferred angle is 90 degrees to the vertical (i.e. horizontal) because this is a simpler arrangement.
- e) The fitting and camlock at the connection point are high wear components that often get damaged. To facilitate frequent replacement, a flanged connection instead of a solvent welded joint shall be used to connect the fitting to the tank inlet piping. The flanged joint shall be enclosed in a removable Perspex box to minimise the impact of a gasket failure. Screw fittings shall not be employed in accordance with AS3780.
- f) It shall have a spring-to-close valved (VA82160) drip leg, which is used to check that the delivery line has drained completely prior to disconnection of the hose. The spring-to-close valve automatically shuts when the Operator releases grip on the manual actuator, thereby preventing risk that the drip leg valve mistakenly gets left open during chemical deliveries.
- g) A safety shower and eye wash shall be provided at apron level between 2 and 7m from the transfer point<sup>15</sup> for use of the driver. A 600mm wide clear access route to this shower shall be maintained at all times. Any platform or stairs projecting onto the load-in apron shall be designed so that access to the safety shower is not restricted or impeded, especially when the truck is parked up

<sup>11</sup> Recommendation from Coogee Chemicals “Bulk Storage Installation Guide”.

<sup>12</sup> AS3780 Cl 5.5.7 (d) iii requirement.

<sup>13</sup> AS3780 Cl 5.5.7 (c) requirement.

<sup>14</sup> Where required, the connection point is elevated 2 to 2.2m above the load-in apron to facilitate draining of residual chemical back into the tanker upon completion of delivery.

<sup>15</sup> AS3780 Cl 5.5.7 (f) requirement.

for unloading. Where a platform is provided, a safety shower and eyewash shall also be provided at that level.

Depending on the delivery requirements, chemical load-in panels may have to be located on an elevated platform so that any residual chemical in the flexible hose after transfer will drain back to the tanker. This has not been a requirement for current sodium hypochlorite delivery as the hose is air purged at the end of the unloading. However, this should be confirmed before the design work is carried out. The photo below shows an example of a raised platform configuration.



**Figure 4-1: Example of a raised load-in platform**

The load-in panel shall be located inside the sodium hypochlorite building so it is over the bunded area. A roller shutter door with thermal insulation shall be provided to gain access to the load-in panel for the tanker hoses. The load-in panel shall be constructed from PVC sheeting (nominally 12mm thick) with FRP frame and supports. It shall have a drip tray which runs the full length of the panel and extends well clear of the valves and transfer point mounted on the panel to collect any drips. The tray shall have additional side and bottom supports to prevent cracking of PVC welds due to the weight of hose and operator. The front of the tray shall have a rolled over reinforced edge to act as an intermediate support for the transfer hose. The drip tray shall be graded towards a drain that is piped to the bund sump. Although directing the spillage to the bund sump could set off the high conductivity alarm unnecessarily, the amount of chemical left over after a normal delivery is usually not enough to trigger off the high conductivity alarm in the bund sump.

Along with the camlock, the load-in panel shall have the following valves and equipment mounted on it:

- a) Tank filling line isolation valves (VA82111/82121);
- b) Drip leg isolation valve (VA82160);

- c) Large sized tank level indicators (LI82115/LI82125);
- d) Tank high level visual alarms (LAH82115/LAH82125);
- e) Tank high level visual and audible alarms (LAHH82134/LAHH82144);
- f) Load-in apron sump drain valve VA82105 position indicator lights (ZIH82105/ZIL82105);
- g) Load-in apron sump high level indicator light (LAH82104);
- h) Manual alarm (light/siren) test pushbutton (HS82108);
- i) Alarm acknowledge pushbutton (HS82109); and
- j) A tank/bund pump-out connection point with isolation valve (VA82158).

The tank/bund pump-out connection point is a DN50 female polypropylene camlock coupling with matching dust plug which is used to remove sodium hypochlorite from the bund sump or directly from the tanks in the event of a significant spill or for maintenance. A valved water inlet point for flushing and priming of the pump-out piping shall be also provided.

The displays, lights and sirens shall be mounted on the load-in panel as far apart as is practical from the load-in point in order to minimise corrosion of the instrumentation. The manual alarm (light/siren) test pushbutton is provided so operators and maintainers can simply and routinely check alarm light and siren operation without having to first generate or simulate an alarm condition. Similar to the safety showers, the alarm light and siren should be tested every time before unloading sodium hypochlorite into the tanks.

The digital readout display of the tank level indicators shall be clearly legible to the delivery driver during unloading, who would likely be standing next to the transfer pump control on his truck a few meters away. The digital readout display shall therefore have a minimum character height of 38mm with a sunshade fitted on top to prevent glare.

All valves and equipment mounted on the panel shall be mounted at an easily accessible level (no higher than 1.8m above floor level is preferred) and shall be clearly labelled with an engraved traffolyte tag number (red tags for critical equipment, white tags for all other equipment) and functional description e.g. VA82111 HYPO TANK 1 FILL VALVE. Other signage which shall appear on the load-in panel includes the maximum fill level label as described in section 12, Placarding, Labelling & Signage.

The purpose of the maximum fill level label is so the operator and delivery driver can check that there is sufficient storage space in the tanks to accept the delivery load prior to commencement of the unloading. The units used on the maximum fill level label for sodium hypochlorite shall be in litres and match the units used on the tank level indicators, which should both match the units used on the delivery docket. This will eliminate the need to provide a conversion chart on the load-in panel.

All pipework and connections shall be rigidly fixed by pipe supports fastened to the load-in panel. All fixings on the panel shall be 316 SS.

An example of a load-in panel arrangement illustrating these requirements is shown in drawing JD71-070-082-06.

## 5 STORAGE SYSTEM

### 5.1 Tanks

#### 5.1.1 Tank Number and Sizing

At least two (2) tanks shall be provided for storing sodium hypochlorite. The storage tanks shall be inter-connected at their outlets, operating together as a combined storage volume with the tank outlet isolation valves normally open. A tank can be isolated for specific maintenance activities whilst the other tank(s) continues with uninterrupted supply of sodium hypochlorite for the dosing system.

Shelf-life is a major concern in the storage of sodium hypochlorite as its strength degrades over time. At the same time, the frequency<sup>16</sup> of sodium hypochlorite deliveries (which impacts the reliability of continuous disinfection of the drinking water or recycled water supply) has to be taken into account in determining the bulk storage volume at a sodium hypochlorite dosing facility.

Minimum working volume storage (not to be confused with tank design capacity) in the metropolitan area is 10 days' supply at peak flow to allow for non-delivery period over long holiday period such as Christmas and New Year holidays. Although it should not exceed 14 days at peak flow to avoid excessive sodium hypochlorite degradation from unnecessary prolonged storage, the working volume storage should be optimally designed to ensure the frequency and quantity of deliveries are manageable, particularly in remote areas. Design of the chemical storage should address the delivery logistics at the particular location taking into consideration any nearby facilities on the same delivery route as sodium hypochlorite may be delivered in "milk runs" for small sites. Water Corporation Procurement Branch and the sodium hypochlorite supplier should therefore be consulted early in the design to ensure a reliable supply of sodium hypochlorite later when the proposed dosing facility is in operation. Storage requirement could be reviewed for regional areas to align with the particular site conditions.

The storage tank shall be sized substantially larger than the normal re-order quantity to assure that there is sufficient capacity to receive the delivery from the truck even with some remaining chemical in the tank. The tank will have a "reserve volume" between the re-order level (low alarm level) and the low low alarm level. The "reserve volume" provides a reasonable time period between when a re-order quantity can be accepted (when the low level alarm is activated) and when the delivery truck actually arrives. Under no circumstances shall the portion of the tank volume that is above the high level alarm be considered as part of the available working volume.

#### 5.1.2 Tank Materials

The sodium hypochlorite storage tanks shall be constructed of a material that is resistant to sodium hypochlorite with a concentration of 12.5% w/v (12.5 grams of available chlorine per 100mL of solution) which practically excludes most metals except for expensive titanium. The Corporation has used black high density polyethylene (HDPE) in the past and observed tank degradation. International standards no longer recommend the use of HDPE for the long term storage of sodium hypochlorite. As a result, HDPE **shall not** be used for bulk storage tanks, with only GRP material being permitted in accordance with SPS 498. Sodium hypochlorite storage tanks shall only be installed inside a covered building to avoid rapid deterioration of the stored sodium hypochlorite due to exposure to heat and UV light.

#### 5.1.3 Sodium Hypochlorite Storage Tank Design

Each tank shall include as a minimum the following nozzles and fittings:

- a) One (1) flanged tank fill point inlet nozzle on the tank roof;

---

<sup>16</sup> Currently tanker delivery in the metropolitan area is generally once a week with non-delivery on weekends and public holidays.

- b) One (1) flanged process outlet nozzle on the side of the tank;
- c) One (1) flanged tank overflow nozzle with overflow pipework supports. The invert level of this outlet shall be specified;
- d) One (1) flanged tank vent nozzle at the highest point on the tank roof;
- e) One (1) flanged scour outlet nozzle on the bottom of the tank, or on the side if provision is made to ensure that the scour can drain the entire tank – e.g. inclusion of a sloping false floor;
- f) Two (2) flanged nozzles, one vertically in line with the other, on the side of the tank for mounting of a magnetic level gauge;
- g) One (1) flanged nozzle on the side of the tank for connecting to a pressure transmitter;
- h) One (1) flanged gas purge return nozzle on the tank roof;
- i) One (1) flanged side inspection port of diameter 300 mm, to allow camera based inspection of the tank interior or entry of a hose for flushing/cleaning purposes<sup>17</sup>. The inspection port needs to be airtight when closed; and
- j) Sufficient lifting lugs;

Each tank shall have an integral non-removable roof. The floor of the storage tank shall be graded towards the scour outlet to ensure the tank can be drained completely. A false floor may be required to achieve this requirement.

Each tank shall be designed for the following criteria:

- a) Contents: 12.5% to 13.5% weight/volume sodium hypochlorite solution.
- b) Operating & Design Temperature: range appropriate to the site
- c) Operating & Design Pressure: atmospheric and hydrostatic
- d) Roof Live Loading: 1.25kPa

Adequate fixings at the base of each tank shall be provided to resist all seismic and wind loads as appropriate for the area.

In accordance with DS31-02 all flanges shall be Class 14/16 to AS 4087, unless a different flange standard has been adopted for the site for consistency. All flange bolt holes shall straddle the centre line.

All nozzle isolation valves shall be hard flanged to the tank nozzles and shall be sized according to the respective nozzle flange size, not the outgoing pipe size if it happened to be smaller than the nozzle. Ensuring no other fitting between each isolation valve and the tank minimises the risk of potential leakage on isolation.

The designer should provide drawings to the tank supplier which clearly shows the desired location and size of all connections and fittings on the tank(s).

A permanently affixed corrosion resistant compliance plate<sup>18</sup> shall be provided on the outside of the tank<sup>18</sup>. This plate is best located at eye level and positioned so it can be read without stepping down into the bunded area. The characters shall be at least 5mm high and it shall contain the following information:

- a) Manufacturer's name or Registered Trademark
- b) Date of manufacture (month and year)
- c) Serial number
- d) Tank Identification number or Tag number

<sup>17</sup> Current philosophy of S&WB and In-Service Assets with regards to CSE (confined space entry) is to totally preclude personnel entry into chemical storage tanks.

<sup>18</sup> AS3780 Cl 5.7 requires certain information concerning tank details to be available to a DMIRS inspector.

- e) Design Capacity (Volume L)
- f) Maximum design service pressure and temperature
- g) Maximum design specific gravity of content
- h) Material of manufacture and grade
- i) Design Code/Standard

Commissioning Plan Information
<p>Prior to delivery to site, all tanks shall be hydrostatically tested using clean water filled to the overflow level at the workshop. The full static head is to be held for a minimum of 12 hours. Once installed, the tanks should be hydrostatically tested to the full static head again to check for any damage which may have occurred during transportation or installation<sup>19</sup>.</p> <p>All tanks shall be transported to site with blind flanges fixed to all nozzles to prevent dust and vermin entering vessels. If a crane is required to install tanks then soft sling rigs shall be used on the shackles so as not to damage the lifting lugs.</p> <p>Testing, transportation, quality assurance and other design and manufacturing requirements for GRP tanks are specified in SPS 498.</p>

### 5.1.4 Tank Plinth

A concrete plinth or tank stand shall be provided for each storage tank so that its base is at least above the 110% bund fill level. The bund floor shall be designed to support the tank plinth or stand with a tank full to the top of its wall. Electrical and control cabling to tank valves and instruments shall be installed above the plinth level so that they shall be precluded from any inundation of the bund.

## 5.2 Tank Instrumentation

### 5.2.1 Tank Level (Pressure) Transmitter (LIT82115/LIT82125)

An externally mounted pressure transmitter shall be provided to measure sodium hypochlorite in each storage tank. The signal from the pressure transmitter shall be used to calculate the amount of sodium hypochlorite in the tank and to generate high level and low level alarms. This quantity shall be displayed locally at the load-in panel as well as on the OIP and HMI. The preferred display quantity unit is litres for sodium hypochlorite.

The high level alarm generated by the pressure transmitter shall isolate the GPO used by the delivery tanker transfer pump (if provided) and activate a flashing light on the load-in panel to alert personnel that a high level in the tank has been reached and there is the potential for a tank overflow if the unloading operation is not terminated. The high level alarm is termed the “Maximum Fill Level” and shall be set at a level which corresponds to 2 minutes (~260L or 1000L depending on the transfer pump flow rate) before a tank would commence overflowing during a filling operation.

The low level alarm generated from this instrument is used to notify the operator that the sodium hypochlorite re-order level has been reached and should be set at a level which corresponds to the tank being sufficiently empty to receive a full delivery of chemical. The low low level alarm shall be set at just above the invert level of the tank process outlet and is used as a trigger to close the tank isolation valve VA82137/VA82147 and shut down the sodium hypochlorite dosing system to prevent the dosing pump from running dry. These alarms and their set points are discussed further in the control functional specification (DS73-02).

The pressure transmitter shall be mounted on a sturdy bracket at a convenient spot near the base of the tank. It shall be mounted on an angle with the pressure connection end facing upward to prevent gas

<sup>19</sup> Water used for testing tanks at site can then be discharged through the scour valves to test the bund as well.



accumulation at the transmitter<sup>20</sup>. The impulse line connecting the tank to the transmitter shall be from a separate tank outlet other than the scour outlet to avoid possible blockage in the impulse line due to settled sludge. An isolation valve shall be provided at the outlet nozzle. Where it connects to the transmitter, the impulse line shall be installed at a gradient to allow any gas to rise away from the transmitter and vent off through the tank vent pipe.

The material on the wetted part of the pressure transmitter shall be corrosion resistant and compatible with the concentrated sodium hypochlorite. If a diaphragm seal is required to protect the transmitter, the material of the seal and other components that will be exposed to sodium hypochlorite shall be fully compatible with the chemical.

Pressure transmitters are preferred to ultrasonic level detectors because:

- a) They minimise access requirements to top of tank, thereby avoiding occupational safety and health issues associated with working at heights;
- b) Have lower capital cost because no stairway and platform on top of tank are required; and
- c) Calibration is simple using simulated injection of pressure, whereas calibration of an ultrasonic level device requires either manual handling of the sensor or raising levels in the tanks to known levels.

Since pressure transmitters are being used to derive a level in the tank it is important that the specific gravity of the sodium hypochlorite is known when setting up and calibrating the pressure transmitters and level indicator.

Commissioning Plan Information
Confirm accurate calibration of the tank level indication from the pressure transmitter for the specific gravity of the chemical to be stored in the tank.
Confirm high and high high level alarms initiate well before the tank overflows.

Ultrasonic level sensors may be considered for use on tanks less than 2m in height, and the transmitter would be installed so that it is at ergonomic height and accessible from ground level. Advantages of ultrasonic level sensors are:

- less risk to chemical exposure during maintenance; and
- direct measurement of tank level (i.e. not reliant on knowing the specific gravity to calculate tank level).

Note: Radar level transmitters may be considered as an alternative to pressure transmitters. Subject to acceptance by the client Region’s Asset Delivery Representative, an alternative is a radar level sensor mounted above a blank flange on top of the tank. Although installed at height, the requirement to access the top of the tank for maintenance of the radar level sensor is expected to be minimal because corrosion-related deterioration of the sensor is avoided because it is not exposed to chemical fumes, and its transmitter would be installed for access from ground level.

## 5.2.2 Tank Magnetic Coupled Level Gauge (LG82134/LG82144)

In addition to the pressure transmitters, each storage tank shall be fitted with a magnetic coupled level gauge. The magnetic coupled level gauge provides a simple, continuous and positive indication of the tank contents and thus a cross-check of the pressure transmitter. This eliminates the need to periodically spot check the pressure indicator. It also provides a back-up level measurement device in the event of power failure and level verification for an operator when the tank re-order point (low level alarm) has been triggered.

<sup>20</sup> Lesson learnt from Hamilton Hill site. The pressure transmitter installation has to be modified so that it is mounted on an angle to allow gas to rise up through the vent line away from the transmitter.

Each tank magnetic coupled level gauge shall be of bar graph indicator type with a red/white (flip/flop) display that is visible from the tanker unloading apron. Shuttle types are not acceptable as they can lose linkage to the float. A level of float positive buoyancy shall be acquired against the lowest possible specific gravity to ensure the float remains in position for all normal and abnormal operations. A high magnetic sensing level switch shall be added to the magnetic coupled level gauge to provide protection against tank overflow (triggering de-powering of the GPO used by the delivery tanker transfer pump in a similar fashion to the pressure transmitter high alarm), independent of the pressure transmitter generated high alarm.

Each magnetic coupled level gauge will be plumbed to side connections on the storage tanks complete with isolation, scour and flushing facilities as shown on the standard drawings. The valves allow the gauge to be removed without having to drain the tank. The float chamber shall be constructed of materials suitable for contact with sodium hypochlorite. Glass material shall not be used as the caustic in the sodium hypochlorite will etch this over time. Valve seats shall be Teflon® with Viton® rubber compounds and gaskets which are more resistant to sodium hypochlorite.

## 5.3 Storage System Pipework

### 5.3.1 Filling Line

The sodium hypochlorite storage tank filling lines shall be DN50 minimum. The fill line into the tank should be located diametrically opposite the outlet pipe to minimise the possibility of any air entrainment during filling from interfering with the operation of the dosing pump. The fill line shall enter the tank above the overflow level.

Apart from a small section of fill pipework which is mounted on the load-in panel, the filling line shall be sloped 1 to 50 minimum to drain back to the tank. The onboard tanker pumps used for delivery are capable of pumping up to a 10-metre head typically, therefore the height of the filling line should not exceed this height.

Commissioning Plan Information
Prior to the first delivery of chemical, the filling line shall be hydrostatically pressure tested in accordance with AS 4041 to 1.5 times the operating pressure of the tanker pump and held for a minimum of 30 minutes. Written proof of this test will be requested by the chemical Supplier and shall be made available to them.
Note: The tank shall not be subject to the test pressure as it is only rated for static head up to the overflow level.

### 5.3.2 Vent Line

Each tank shall have a vent line to allow venting of fumes during tank filling and vacuum relief during tank emptying. The vent line shall be sized to ensure adequate air flow out of the tank during a filling operation (including air purging) and adequate air flow into the tank whilst the dosing pump is operating or the tank is being drained, without exceeding the maximum allowable operating stresses of the tank. As a minimum, the vent size shall be two times the diameter of the filling line.<sup>21</sup> In most cases this will be DN100 for tanks of size less than 20,000L.<sup>22</sup> Consideration should be given to using DN150 for larger tanks.

The vent line shall discharge outside the building at about 500 mm above the site finished surface level, which is high enough to observe any potential dripping, but low enough that it is unlikely that any drips will fall on personnel. The vent discharge point shall be weather-proofed and shall be fitted with a “tropical midge wire” insect screen. The vent outlet shall be located such that it is possible to gain

<sup>21</sup> The Chlorine Institute, Pamphlet 96, Sodium Hypochlorite Manual, Edition 4.

<sup>22</sup> Sodium Hypochlorite – General Information for the Consumer, Odyssey Manufacturing Co.

access to it for maintenance purposes, and shall be located at least 4m away from the load-in bay so as to avoid exposing the load-in operators to fumes during tank filling.

The vent line shall be securely supported to prevent excessive stress on the tank roof. The vent pipework shall be configured so that condensation of vapours is directed back into the tank. It is important to always ensure that the vent line is not blocked.

### 5.3.3 Scour Line

There shall be a DN50 minimum scour outlet line from each tank which is plumbed to the bund sump. The scour piping shall be interconnected to the bund sump pump-out line to enable the contents of the tank to be directly loaded to a truck if required, without firstly dumping it into the bund sump.

A DN50 minimum manual isolation valve (VA82130/VA82140) shall be installed as close to the nozzle flange as possible. The scour valves are required to be operated without the operator entering the bund, and so the scour outlet should be located at the edge of the FRP grating or removable cut outs shall be provided in the grating to access these valves. Securely supported extension spindles to bring the valve handles to a comfortable height for ergonomic operation may be required.

Tanks shall be fabricated to allow the entire tank including any sludge that may have settled on the tank floor to be drained out completely. Provision of a sloping false floor inside the tank with appropriate piping is one way to ensure complete emptying of the tank.

### 5.3.4 Process Line

The process line supplies sodium hypochlorite from each tank to the duty dosing pump located at the dosing panel. The diameter of each tank process outlet nozzle and valves should be at least equal to the tank inlet diameter, typically DN50. The process line from each tank interconnects at a tee before proceeding to the dosing panel on a common pipeline. The diameter for the common process pipeline after the tee fitting may be reduced to achieve a higher flow velocity (say 0.5m/s) if required.

To minimise the sodium hypochlorite retention time in the piping, the process line to the dosing pump shall be kept as short as possible. The piping from the storage tank shall be graded downward to allow gases in the solution to be released back into the tank. At the dosing panel, the piping shall be graded up towards the calibration tube which acts as a vent tube to purge any gas bubbles prior to entering the dosing pump.

The manual tank outlet valve of each tank (VA82135/VA82145) shall be flanged directly to the process outlet nozzle and be easily accessible so flow of sodium hypochlorite from the tank can be shut off in the event the motorised tank outlet isolation valve fails. The handles of these valves shall be located above the bund wall level so that they would not be submerged if the bund was to be filled to the 110% fill level and shall be accessible without having to enter the bund.

The actuated tank outlet isolation valves (VA82137/VA82147) are normally open but in the event of high sump level alarm occurring in conjunction with a high sump conductivity alarm, or when the tanks are nearing empty (LALL82115/LALL82125 activated), an automatic closure of these valves shall be triggered which leads subsequently to the shutdown of the sodium hypochlorite dosing systems. It is not considered to be critical for these isolation valves to be specified to fail-closed as the chance of a major leak during a power failure is low, and even if it had occurred, the spillage would still be contained in the bund,

To allow differential movement and help reduce stress on the tank and piping, a flexible connection (eg. bellow) shall be installed after the manual outlet valve.

Detail 1 on drawing JD71-070-082-05 provides an example of the process outlet pipework arrangement. As the process line is likely to have a low section between the tank and the dosing panel, where it runs beneath the gridmesh, it is necessary to provide a manual drain valve along this line to facilitate the complete emptying of this line prior to maintenance. These drain valves shall be DN15 ball valves with securely supported extension spindles so their handles are located just below the gridmesh grating for ease of operation (using an extension spindle). As these valves have the potential to drain the sodium

hypochlorite storage tanks, their open/close position along with their purpose shall be clearly marked with appropriate signage and their handles shall be lockable to prevent accidental or inadvertent incorrect operation.

### 5.3.5 Overflow Line

Each tank shall have an overflow pipe sized at not less than 1.5 times the filling line, which shall discharge 200 mm above the bund sump. The overflow line shall have a fillable seal bend to prevent fumes from releasing into the dosing room and a sight tube that is visible from the load-in point. Sturdy supports must be provided to the overflow piping to avoid excessive loading on the tank nozzle. No valves or equipment which could potentially cause blockages shall be installed in the overflow lines. Care shall be taken on the overflow line design to ensure that no liquid can be drawn back into the tank under any conditions.

### 5.3.6 Gas Purge Return Line

A gas purge return line from the dosing panels to the tank roof shall be provided for each tank. This line acts as a gas escape route for the degassing valve (VA82221/VA82321), pressure relief valve (VA82204/VA82304) and gas purge column (CC82207/CC82307).

A manual valve (VA82112/ VA82122) shall be provided for each gas return line before the tank nozzle. This normally open valve (with limit switches) will need to be closed when the corresponding storage tank is taken out of service for maintenance whilst the other tank is on duty. At least one of these valves must be fully open at any time if there is sodium hypochlorite present in any of the panels and dosing pipework. If fully open signals are not present for both gas return valves VA82112 and VA82122, then the system loses its permissive to operate and alarm ZA82162 “Gas return valves VA82112 & VA82122 not fully open” is activated. ZA82162 will initiate the shutdown the dosing system if it is operating and trigger a “Water Quality Poor” alarm.

## 6 DOSING SYSTEM

### 6.1 General Considerations

Sodium hypochlorite is prone to gassing off and crystallization if allowed to lie static even for short period of time. The off-gas bubbles in the suction piping tend to stay locked in suspension and over time, cause vapour locking problems in the diaphragm dosing pump. Oxygen gas produced will also build up pressure in the pipework to the point of catastrophic failure if there is no outlet for the trapped gas to escape. Sodium hydroxide (caustic soda) in the sodium hypochlorite has a tendency to precipitate and leave a crusty residue which can cause ball valves to get stuck making them inoperable.

Dosing system must therefore incorporate measures to mitigate the effects of gas build-up. Such measures shall include installing the dosing system pipelines with gradients such that gases formed can be expelled and vented out through degassing valves and/or gas purge columns. Pipe lengths are to be kept short and over-sizing of the piping, valves and pumps are to be avoided to minimise sodium hypochlorite detention time in the system. Dosing pipes transporting neat sodium hypochlorite solution should ideally be sized to maintain a flow velocity of 0.5 m/s to 2 m/s to reduce gas accumulation<sup>23</sup> but this is not always possible. The pipes are usually selected to keep the size as small as the flow rate will allow. To maintain flow velocity, the number of obstructive fittings such as bends, tees and reducers should be kept to a minimum. Ball valves shall have pre-drilled balls to prevent trapping of sodium hypochlorite in the cavity between the valve body and the ball.

### 6.2 Materials of Construction

All materials of construction used in any part of the process system that comes in contact with sodium hypochlorite will have to be compatible with it. Incompatible materials that come in contact with sodium hypochlorite will result in accelerated degradation of the chemical and formation of oxygen gas. Care must be taken to select equipment for use in the sodium hypochlorite dosing system as incompatible metals such as stainless steel, brass or copper are often found in pumps, pump seals, check valve springs, electrodes in magnetic flow tubes, and diaphragm seals for gauges, switches and transmitters. Generally all metals should be avoided with the exception of titanium, tantalum, silver, gold and platinum.

### 6.3 Dosing Panels

Except where otherwise approved, a separate duty and standby dosing panel shall be provided for the sodium hypochlorite dosing equipment and pipework. Each panel shall have its associated dosing pump and equipment and shall be capable of operating independently and automatically<sup>24</sup>.

Each entire dosing panel shall be enclosed within a cabinet in compliance with DS 79-03 and drawing JD71-6-1. Enclosure of the dosing panel and pump with a transparent front cover (e.g. curtain or framed PVC doors) enables the panel to be viewed during operation, at the same time providing protection of personnel from any chemical spray or leak. The panels shall be enclosed separately from each other so that the offline panel can be accessed by the operator without the risk of him/her being exposed to chemical from the duty panel.

Integral with the dosing panel is a drip tray at its base, which is graded to a drain that is piped to the bund sump. The drip tray shall extend well clear of all panel appurtenances so that all chemical leaks are captured by the tray.

The dosing panel shall consist of a minimum 12mm thick PVC board and drip tray, all mounted on a stainless steel or suitably surface protected steel frame. The steel frame shall incorporate lifting lug(s) to enable easy placement and future removal of the entire panel. The dosing panel shall be wall mounted,

<sup>23</sup> Sodium Hypochlorite – General Information for the Consumer, Odyssey Manufacturing Co.

<sup>24</sup> One dosing panel with duty and standby dosing pumps may only be approved if the system is non-critical because it can be readily shut down for maintenance – e.g. it is an intermittent operation or maintenance downtime is acceptable because of sufficiently large drinking water storage or other similar reasons.

with a minimum clear space of 500mm between the wall and the back of the panel for the passage of piping, cabling and services. Equipment and piping shall be neatly arranged on the dosing panel. Different pipe sections should not cross each other unless unavoidable.

### 6.3.1 Calibration Tubes (CC82207/CC82307) and Pump Suction Piping

The calibration tube/gas purge column on the dosing panel serves two functions. As a calibration tube, it is used for fault finding and for calibrating the performance of new and replaced pumps during commissioning/re-commissioning. The calibration tube shall have sufficient capacity to allow a single calibrating run of at least two minutes duration when operating the dosing pump at full design flow rate.

The tube also serves as bubble-trap or gas purge column where gas from solution can be vented out just prior to entering the dosing pump head to prevent vapour lock. The suction piping before the pump should be configured in a specific manner to allow for this disengagement of the gas bubbles to occur. As it enters the dosing panel, the pipe conveying the sodium hypochlorite should slope up towards the calibration tube to allow gases to rise and expel into the vertical column before continuing on to the pump. The short section of the pipe from the calibration tube leading to the pump suction connection should also slope back to the column for the same reason. It is important to keep this section of the pipe as short as possible<sup>25</sup>. An example of the piping arrangement is shown in the drawing JD71-70-082-07 and JD71-70-082-08. Suitable flexible tubing may be used for this section of piping from the calibration tube to the pump. The vent line from the top of the column is directed back to the storage tank through the tank roof.

The calibration tube/purge column should cover the full height of the sodium hypochlorite storage tank to provide full usage reading. The calibration tube shall be constructed out of PVC or similar plastic. Glass tube is not suitable as the caustic in the sodium hypochlorite will react with it and eventually making the glass opaque.

The isolation valve (VA82208/VA82308) below the calibration tube shall remain open at all times except during flushing to allow gas to escape even when the system is shut down. It will need to be closed during flushing to prevent water getting into the calibration tube and sodium hypochlorite storage tanks.

### 6.3.2 Sodium Hypochlorite Dosing Pumps (PU82210/PU82310)

There shall be a dosing pump for each dosing panel.

Positive displacement mechanical diaphragm pumps are typically used in the Corporation's sodium hypochlorite facilities. Each pump shall comply with the requirements of the Water Corporation's Mechanical standard DS32 and shall include pump fault detection (e.g. diaphragm leak), an integral pressure relief system and manual stroke adjustment. Pumps operating at less than 20 L/h flowrate shall have an integral de-gassing capability. Hydraulic fluid for hydraulically actuated diaphragm pumps shall be of medical quality. The pump shall be suitable for automatic speed control via a variable speed drive. There will be a provision in the control to set a minimum pump speed limit to prevent damage to the pump motor and at the same time prevent infrequent "slugs" of sodium hypochlorite dosage.

Materials of construction for wetted parts of the pump in direct contact with sodium hypochlorite shall be compatible and resistant to the solution. Metals such as stainless steel, Monel<sup>®</sup>, brass or copper must be avoided. Suitable diaphragm materials are Teflon<sup>®</sup> or Viton<sup>®</sup> stabilized with carbon black.

Each pump shall be mounted on a PVC plinth attached to the dosing panel and so that the pump can be adequately accessed from all sides for adjustment and servicing.

Diaphragm pumps are susceptible to vapour locking and shall not be used unless otherwise approved by the Senior Principal Engineer Water Treatment. Measures recommended to reduce vapour locking of the pumps include the following:

---

<sup>25</sup> It has been recommended to be no more than 300mm in length in the KWS Investigation Report by P. Hanley (with installation standard drawing and notes Rev 8)

- a) Ensure pumps are operated with flooded suction. Pumps should be installed below the storage tank lowest operational level for this reason, but at the same time, should not be installed below the top of the bund wall level to avoid submergence during a major spill. Suction pipeline should be made as short as possible with the correct sizing for minimum dwell time.
- b) Avoid pumps that have perforated contour plates inside the pump’s head that are in direct contact with the sodium hypochlorite solution. The perforations of the contour plates have been identified as locations where the sodium hypochlorite solution is drawn through at high velocity during each stroke, thereby releasing oxygen gas inside the pump head, causing vapour locking<sup>26</sup>. Pumps with hydraulically actuated tubular diaphragms have been found to be effective in reducing the effects of off-gassing.
- c) Avoid oversizing of pumps. Pumps should be operated with long stroke length between 50% and 100% to keep new solution coming in and to push most of the air bubbles out<sup>27</sup>. Automatic control of dosing should be carried out by speed control via a variable speed drive.

Peristaltic pumps that utilize a flexible tube or hose inside a circular housing have been used for sodium hypochlorite dosing. This type of pump does not require inlet and outlet check valves and is not as vulnerable to off-gassing and vapour locking. Accordingly, peristaltic pumps do not require as many piping appurtenances as do diaphragm pumps. However, trial of this type of pump at one of Water Corporation’s dosing facilities<sup>28</sup> has found that the peristaltic pump did not perform well under the existing dosing conditions. The flexible tube used on the pump lasted approximately 230 hours on average which was clearly not acceptable. As the tube degraded, it was found that the pump delivery reduced accordingly, requiring frequent adjustments of the pump to maintain the desired sodium hypochlorite flow. The trial concluded that peristaltic pumps are not recommended to be used especially pumping into high back pressure.

Digital diaphragm dosing pumps have advanced features capable of smooth continuous dosing with flow measurement that can be integrated in a Profibus DP network whilst having the ability to detect and automatically push out air bubbles from the dosing head. If specific performance of this type of pump demonstrated these capabilities across the operating range, some of the auxiliary equipment on the dosing panel such as pulsation dampener and flow meter may be omitted, if approved, where this type of “smart” pump is installed.

Small dosing pumps may require short lengths of flexible hose or tubing at the pump suction and discharge ends as described in section 8.6.

Pumps shall be set up for auto-degas and autoflow adaption where those features are available.

Provide capability for the dosing pumps to change over automatically on an adjustable set time period e.g. daily or weekly. This will help ensure the pumps have similar operating hours and are not offline for long periods.

### 6.3.3 Pressure Safety (Relief) Valves (VA82204/VA82304)

Dose pumps with internal pressure relief provide the advantage of minimising complexity of the dosing system. Where a dosing pump does not have an internal pressure relief system and relief alarming, a separate external pressure safety (relief) valve shall be installed in a bypass arrangement around the dosing pump (i.e. pressure shall relieve to the suction side of the pump). The pressure safety (relief) valve shall be set to open on failure (i.e. fail open).

Commissioning Plan Information
The pressure setting of pressure safety valves (PSVs) shall be recorded on their (red) valve tags.

<sup>26</sup> White’s Handbook of Chlorination and Alternative Disinfectants, 5<sup>th</sup> Edition by Black & Veatch Corporation.  
<sup>27</sup> White’s Handbook of Chlorination and Alternative Disinfectants, 5<sup>th</sup> Edition by Black & Veatch Corporation. A pump speed of around 20 strokes per minute is also recommended.  
<sup>28</sup> Balcatta Hypo Dosing Plant from Nov 2010 to Mar 2011.

### 6.3.4 Strainers (ST82203/ST82303)

To prevent pipework shavings, silica scale, or other solid impurities from blocking or damaging the dosing pump internals, the magnetic flow meters or the pressure sustaining valves, it is required that a PVC in-line Y-body strainers be installed upstream of the dosing pumps before the calibration tube. As a minimum the strainer shall be fitted with a cylindrical mesh having 0.5mm sized perforations. As duty/standby panels are recommended there is no need to provide a bypass around the strainer. However, for single panel systems a bypass, complete with standby strainer, will be necessary to keep the panel running whilst the blocked strainer is taken out for service.

### 6.3.5 Pulsation Dampeners (PD82216/PD82316)

The pulsation dampener absorbs the pressure surges from the dosing pump’s reciprocating strokes and smoothens out the dose flow. It shall be correctly sized to suit the dosing pump stroke volume. There are various equations available to calculate the correct pulsation dampener size. Each pulsation dampener supplier generally has their own equation based on the percentage of pressure dampening required. 95% dampening (2.5% above and 2.5% below the mean operating pressure) is an acceptable target. An easy rule of thumb provided by a pump manufacturer<sup>29</sup> is that to achieve a 90% reduction in pulsation a dampener volume that is 26 times the maximum stroke capacity is required.

Commissioning Plan Information
The pressure setting of pulsation dampeners shall be recorded on their equipment tags.

Pulsation dampeners should be installed in a vertical position close to the dosing pump discharge outlet. Pulsation dampeners shall be constructed of materials suitable for contact with sodium hypochlorite such as PVC bodies with Hypalon or Teflon bellows. They should be charged with nitrogen or compressed air, to a pressure just high enough to achieve dampening as per the manufacturer’s recommended procedure.

Certain pump types do not require the installation of Pulsation Dampeners. Approval to not install a Pulsation Dampener shall be obtained from the Senior Principal Engineer Water Treatment or Senior Principal Engineer Mechanical

### 6.3.6 Pressure Gauges (PI82218/PI82318)

A glycerine-filled stainless steel pressure gauge with a minimum display diameter of 63mm (2.5”) shall be provided with sufficient range to allow setting of each pressure sustaining valve and to assist in continuous monitoring of correct pump performance. The pressure gauge shall incorporate a diaphragm barrier seal of suitable material such as Titanium or Tantalum), to prevent sodium hypochlorite coming directly into contact with the gauge components. The gauge scale shall be sized so that the maximum operating pressure will not exceed 75% of full scale.

### 6.3.7 De-Gassing Valves (VA82221/VA82321)

An automatic valve is required on the pump discharge to bleed off gas that has accumulated in the pump and delivery pipeline. The de-gassing valve shall be set to open at preset time or intervals for user defined durations from the OIP. This preset shall include 10-20 seconds (adjustable) opening on pump operating at full speed on start-up. On closure of the valve, the pump should continue to be operated at full speed for a preset period of time to assist in clearing the line before adjusting to the required dosage.<sup>30</sup>

Solenoid operated valves have been used in the past for de-gassing but this type of valve has been reported to have reliability issues due to sodium hydroxide crystal formation, with a typical short lifespan of less than a year. Some of these solenoid valves have since been replaced with actuated ball valves successfully. The actuated ball valve has been found to provide significantly better reliability

<sup>29</sup> Prominent Pumps website.

<sup>30</sup> KWS Investigation Report by P. Hanley (with installation standard drawing and notes Rev 8)



over the solenoid system. Unless the client insists otherwise, actuated ball valves shall therefore be used as for the de-gassing function.

The delivery pipework on the panel shall be graded up on a minimum gradient of 1:100 to the point where the de-gassing valve is located. The pipework after the de-gassing valve shall have a clear PVC sight tube and be connected to the vent line that runs from the calibration tube/gas purge column to the storage tank.

The de-gassing valve should be set to open upon valve failure (fail open), in the event of a power outage or when its dosing panel is taken off-line as in the case when the duty panel is switched over. This will minimise gas accumulation in the idle pipework.

### 6.3.8 Magnetic Flow Meters (FIT82224/FIT82324)

The flow meter installed on each panel shall be a magnetic flow meter sized for accurate operation over the full range of sodium hypochlorite flows. It shall be selected from one of the suppliers on the Water Corporation's Preferred SCADA Instrument Equipment List.

The flow meter is used to monitor and record the sodium hypochlorite dosing pump discharge flow rate, and totalise the amount of sodium hypochlorite dosed. A low flow alarm (configurable) would indicate a dosing hydraulic fault such as blockage at the dosing spear, and would initiate shutdown of duty dosing system and changeover to the standby system.

The flow meter shall be installed on the panel via wafer or flanged connections (for easy removal) with 10 sensor diameters upstream and 5 sensor diameters downstream of straight uninterrupted pipework. To ensure correct measurement the flow meter shall be mounted on the panel in an orientation such that the pipe is always full, and air and deposits do not accumulate in the measuring tube. Suppliers should be consulted for guidance on the best arrangement for their models. The flow meter shall be located between the dosing pump and the pressure sustaining valve. This is so the accuracy of the flow meter is not affected by pressure fluctuations that can occur on the downstream side of the pressure sustaining valve.

Due to the small sensor diameter of these small magflow meters they can be prone to blockages from scale build-up. In the event of complete obstruction which cannot be cleared with flushing, the normally closed bypass that has been included around the magflow and pressure sustaining valve, can be opened to allow pressure relief and flushing of the remaining pipework prior to disassembly for maintenance. If really needed, the bypass around the magflow ensures continuation of dosing whilst the magflow is taken offline for maintenance.

### 6.3.9 Pressure Control (Sustaining) Valves (VA82226/VA82326)

A pressure sustaining valve (PCV) automatically holds a steady pre-set inlet pressure, within close limits. The main pressure sustaining valve (VA82226/82326) installed on the dosing line after the magnetic flow meter on each panel improves the accuracy of dosing by providing and maintaining the necessary discharge pressure<sup>31</sup> required by the dosing pump to work against. It shall be set at a pressure which optimises pump accuracy as per the pump manufacturer's recommendation. The pressure setting shall be recorded on the valve tag.

A normally-closed bypass around the PCV and magflow meter allows the system to be de-pressurised, prior to maintenance, should the PCV becomes blocked or fails. It can be de-pressurised entirely when the downstream drain valve is opened.

---

<sup>31</sup> Pressure is typically set at 100kPa above maximum line pressure, 200kPa minimum - KWS Investigation Report by P. Hanley (with installation standard drawing and notes Rev 8).

For dosing lines longer than 10 metres, an additional PCV<sup>32</sup> and pressure gauge shall be required near the dosing point to provide stable dosing control and help prevent overdosing of the mains water during idling periods (refer to section 6.4.3).

Provision should be made to allow a hand-held gauge to test the pressure on each PCV.

Commissioning Plan Information
The pressure setting of PCVs shall be recorded on their valve tags.

## 6.4 Dosing

The sodium hypochlorite which leaves the panel and exits the sodium hypochlorite building is then dosed into the recipient water main via a dosing spear/sparger arrangement. The design of the dosing system downstream of the dosing panel is described in more details in the chemical dosing design standard DS78.

### 6.4.1 Dilution Carrier Water

Sodium hypochlorite is preferably dosed “neat” at 12.5% (w/v) concentration into the recipient water main. In some installations, a dilution carrier water stream may be required to increase the velocity of the chemical in the feed pipe. This could occur in a system where the sodium hypochlorite dose rate into the recipient water is so low that the sampling pump is unable to consistently pick up representative samples for chlorine residual analysis resulting in erroneous feedback to the dosing pump control.

The main issue with using a carrier water stream is that the sodium hydroxide (caustic soda) in the sodium hypochlorite will react with the calcium and magnesium hardness in the carrier water to induce scale formation in the immediate area of the mixing point. If included as part of the system, the carrier water shall be softened or demineralised to reduce the formation of scale. Alternatively, a sequestering agent such as Calgon - sodium hexametaphosphate (SHMP)<sup>33</sup> can be introduced into the carrier water before diluting the Hypo. The Calgon (SHMP) interferes with calcite crystal growth, thereby preventing deposition of scale on surfaces.

Dilution carrier water for chemical dosing is described in more detail in design standard DS78.

### 6.4.2 Dosing Line

The dosing line from the dosing panel to the dosing point shall be barrier protected in accordance with DS79-03. Where installed, any double containment piping system shall have viewing catch pots at low points for visual detection of any leakage in the pipeline.

If the dosing line is buried, then permanent pipe markers shall be installed to warn operators or others working in the area. These “buried chemical line” signs shall be position at every change of direction and at maximum intervals of 50m.

The dosing line between the metering pump and the application point should be kept as short as possible to minimise the length of time the sodium hypochlorite stays in the pipe. Where redundancy of the external dosing lines is installed, provision shall be made to allow any one of the dose lines to be used by either of the dosing pumps to convey sodium hypochlorite to the dosing points. Cross-connection of the piping shall be provided downstream of the dosing panels.

Depending on the dosing point location and whether it is above ground, or below ground in a pit, the pipework layout and design shall include joints, fittings and valves to enable the removal of the dosing spears. Where practicable, dosing points should be located above ground in order to eliminate confined

<sup>32</sup> This PSV is typically set at 50kPa above maximum line pressure - KWS Investigation Report by P. Hanley (with installation standard drawing and notes Rev 8).

<sup>33</sup> Sites with Calgon SHMP dosing include Carabooda Tank, North Mandurah Tank, Yanchep, Two Rocks and Albany.

space and access/egress issues and improve maintainability. Above ground dose points shall be assessed for chemical barrier protection in accordance with DS79-03.

### 6.4.3 Dosing Diffusers & Valves

Duty and standby dosing diffusers shall be provided. Recipient water mains greater than 750mm in diameter with high flows and pressures normally require a full-bore dosing sparger with locating spigot for support. For recipient water mains less than 750mm in diameter a dosing spear (open ended pipe projecting half-way into the main) should be adequate to provide good mixing. The holes on the dosing sparger should face away from the direction of flow (be on the downstream side of the sparger) and the flow direction should be marked on the flange of the sparger.

Blockage of pipework and sparger orifices caused by scaling is a major problem especially if the recipient water or sodium hypochlorite carrier/dilution water (for small system with low dose flow) contains sufficient levels of alkalinity and hardness. Scaling at some Water Corporation sites has been managed by dosing a sequestering agent such as Calgon SHMP into the dilution stream prior to the addition of the neat sodium hypochlorite. Use of Calgon is generally not preferred because of the disadvantages of being an artificial additive and it increases complexity by introducing an additional dosing system.

Design of the dosing diffusers and/or mixing devices are site specific, and reference shall be made to DS78 Chemical Dosing Standard for guidance.

Dosing spears should pass through a gate valve so that the recipient water main can be operated even when the spear is not in place. Non return valves shall be provided on the dosing line near to the dosing spear to ensure the recipient water does not back-feed up the dosing line when the spears are not in operation. Isolation ball valves shall also be provided to enable the individual spears to be isolated from the sodium hypochlorite and removed for maintenance whilst the other spear is in operation. Some systems may require removable dosing spears or spargers so this potential requirement should be considered in design.

For dosing lines more than 10m in length, a suitable pressure sustaining (control) valve (PCV) and pressure gauge (PI) shall be installed near to the dosing diffuser<sup>34</sup> to provide stable control of the dosing especially during high throughputs. The PCV will also help prevent overdosing of the mains water due to “siphoning” of the long pipeline of sodium hypochlorite into the recipient water during periods of idling when the dosing pump is not operating and the mains water is not flowing. Sites with consistent hydraulic conditions and that operate continuously may not require PCVs – approval to delete PCVs shall be sought from the Senior Principal Engineer, Water Treatment.

The PCV and pressure gauge shall be constructed of materials suitable for contact with sodium hypochlorite similar to those provided at the dosing panels.

## 6.5 Flushing Water System

Flushing water valves and connections shall be provided to flush sodium hypochlorite from the storage and dosing system pipework prior to equipment removal or maintenance. The flushing connections shall be located strategically so that all of the sodium hypochlorite lines, right back to the tank, can be flushed. The valve below calibration tube (VA82208/VA82308) and the de-gassing valve (VA82221/VA82321) must be closed during flushing to prevent water entering the sodium hypochlorite storage tank. VA82208/VA82308 shall be opened after flushing has been carried out. A sign with instruction to close these valves shall be displayed next to all the flushing points<sup>35</sup>.

<sup>34</sup> Similar installations have been provided for FSA at Gwelup GWTP and hypochlorite at Hamilton Hill CDP. PCV typically set at 50kPa above maximum line pressure (KWS Investigation Report with drawing notes Rev 8 by P. Hanley).

<sup>35</sup> Other ways to ensure these valves are closed during flushing have been considered including a keyed valve system but these have been assessed as complex and costly.

Flushing should take place in preparation for maintenance or if sodium hypochlorite had to be left stagnant in the system for long period. It should not necessarily occur simply when changing from one operating mode on a system to another (e.g. Dosing Mode to Stopped Mode), or when changing over from one dosing system (duty) to another (standby). Routine or excessive flushing of the sodium hypochlorite system with unsoftened water will result in scaling in the pipelines, so it should be avoided.

Drainage points should be provided at various locations on the dosing pipeline for draining of the flushing water when required. However, when flushing the sodium hypochlorite system the flush water should best be directed to the dose point as this is the safest and easiest disposal route. During the initial flushing period the dosing operation of the standby system should be suspended to ensure over dosing does not occur.

An option can be investigated at design stage to incorporate some automation to the flushing system to enable flushing remotely if required. A motorised 3-way valve will be required at each flushing point and certain valves on the dosing panel that are required to close during flushing will need to be motorized too. The 'Flushing' mode can be programmed to open and close the appropriate valves automatically when flushing mode is selected on the HMI or OIP.

Site service water is generally used as the flushing water supply and it shall have sufficient head to flush water through both the sodium hypochlorite dosing pump and pressure sustaining valve of the dosing system. If the site service water supply has insufficient flow or pressure to carry out flushing, then a dedicated flushing pump will be required as part of the sodium hypochlorite system. Alternatively, if the site water supply has excessive flow and pressure, which could cause damage to valves and equipment then a flow control valve may be required to limit the flushing flow and pressure.

If the same site service water supply is used to supply safety showers then the flushing water off-take shall be located downstream of a reduced pressure zone device (RPZD).

## 6.6 Safety Shower and Eyewash

A safety shower and eyewash located between 2 and 7m from the dosing panels and on the same level (no stairs or other obstacles along route) shall be provided. Detailed requirements for safety shower and eyewash units are described in section 9.2.

## 7 WATER SAMPLING & ANALYSIS

### 7.1 Sampling Point

The chlorine residual sampling point is located downstream of the sodium hypochlorite dosing point after the sodium hypochlorite has had the opportunity to be mixed thoroughly in the recipient water. At the same time, the sampling point should not be too far from the dosing point to significantly affect the lag time of the dosing control loop.

Depending on the system pressure at the location of this off-take point, the sample may need to be pumped in order to reach the chlorine residual analyser (AIT82419), or reach the analyser in an acceptable time frame to avoid issues with the dosing control. A rotameter (FI82418) fitted with a low flow switch (FSL82418) monitors the feed to the chlorine analyser.

Normally a sample spear with an open end that projects half way into the main is used for sampling. For some large diameter high pressure pipework, however, where mixing is problematic, a full diameter sampling infuser with locating spigot is required. The holes on the infuser should face the direction of flow (be on the upstream side of the sparger).

Sample water should be returned to the recipient pipe where it is feasible to do so. Recovery of sample water may not be cost effective if additional equipment such as pump is required for the purpose.

DS78 Chemical Dosing Standard provides further details and requirements on the sampling system.

### 7.2 Chlorine Residual Analyser (AIT82419)

A chlorine residual analyser is used to continuously monitor the residual chlorine of the treated water and provide feedback residual trim control of the hypochlorite dose rate. The analyser shall be connected to the plant control system to generate High, High High, Low and Low Low alarms when the concentration strays outside of acceptable limits. The High and Low alarms are also used to initiate changeover to the standby system. The sodium hypochlorite dosing system will shut down completely when the High High or the Low Low alarms is reached. “Water Quality Breached” alarm will be generated and shutdown of the recipient water mains source will be initiated to prevent delivery of poor quality water to consumers. The Water Safety Plan (WSP) of the particular site or region should provide all the alarm setpoints and the required action to take.

The analyser should be installed on a sampling panel and at water treatment plant sites the sampling panel should be in a sampling room, laboratory or other covered area suitable for instrumentation. Re-chlorination sites that do not have a sampling room or laboratory will have the analyser sampling panel located in the dosing room.

The analyser shall be selected from one of the suppliers on the Water Corporation’s SCADA Approved Equipment List and it shall be approved by the client prior to purchase. This is to ensure the selection complements other analysers operated and maintained in the client’s region to promote uniformity, familiarity and to possibly reduce spares holdings.

## 8 PIPEWORK AND VALVES

### 8.1 Pipe Materials

All sodium hypochlorite pipework shall be Schedule 80 PVC-U in accordance with ASTM D-1785. Water Corporation has adopted this standard rather than PN18 PVC-U – Series 1 (AS/NZS 1477) in recognition of the pipework typically supplied by contractors and the desire to standardise on one pipe standard. It is recognized that Schedule 80 PVC-U pipe is a superior product in terms of mechanical strength and UV degradation.

The pressure rating of the PVC-U pipe, fittings, valves and appurtenances shall be de-rated in accordance with the manufacturers' specifications for:

- service temperatures above 20°C
- 12.5% sodium hypochlorite chemical service
- solvent cement joint de-rating for 12.5% sodium hypochlorite. Note that at the time of publishing this document George Fischer specifies a 1.6 pressure derating factor with design temperature not to exceed 40°C for solvent cement joints in >6% sodium hypochlorite service for the recommended Tangit DTX jointing compound.

Where multiple de-rating factors apply to a piping component or joint, normally the manufacturer specifies that these are cumulative.

The pressure rating of each line shall be no greater than the lowest pressure rating of the pipe, fittings, valves, flanges, cement joints, or other components that make up the line after allowing for all applicable de-rating factors.

### 8.2 Pipe Sizes

Pipe sizes for pump dosing should ideally be selected to maintain the neat sodium hypochlorite flow velocity as high as possible but under 2 m/s, to sweep oxygen bubbles along and minimise gas accumulation. A velocity higher than 2 m/s will contribute to a shearing effect that will separate the sodium hypochlorite into alternating slugs of gas and liquid, affecting the accuracy of downstream dosing whereas a velocity slower than 0.5 m/s will contribute to gasification and crystallization.

### 8.3 Pipe Fittings

Pipe fittings such as bends, tees and reducers are obstructive to sodium hypochlorite flow and tend to be locations for scale or contaminant deposition. It is thus a good practice to keep the number of pipe fittings to a minimum to maintain the flow velocity. Where used, 90° bends should be long radius type.

### 8.4 Pipework Jointing & Solvent Cements

All PVC-U pipework joints and fittings shall be solvent welded except the tank to pipework connections and some pipework to equipment connections which shall be flanged. The use of screwed fittings shall be avoided wherever possible, but will probably be necessary for the installation of the pulsation dampeners and pressure gauges. If threaded connections must be used, threads must be new, sharp and secured with a high quality caustic resistant Teflon tape.

Sodium hypochlorite is very aggressive and will find its way through the smallest leak point, particularly in a pressurized delivery system. To ensure leak-free pipework, the solvent welded pipe joints shall be made with care and strictly as per the manufacturer's installation instructions and WS-2 Welding and Jointing specification. Over-applying the solvent to the joints should be avoided as excess glue can reach the interior of the pipe and restrict the sodium hypochlorite flow.

The solvent cement used for these joints shall be Tangit DTX solvent cement (use together with Tangit Cleaner).<sup>36</sup> Tangit DTX is a gap filling cement, ideally suited to the larger clearances in schedule 80 PVC piping system fittings. Many other solvent cements / jointing compounds have limited gap filling properties and require a complex jointing methodology, often demanding multiple solvent applications when applied to schedule 80 piping systems. The inability to carry out this complex methodology successfully has led to joint failures at some Water Corporation sites. Tangit DTX has been the preferred solvent cement for jointing PVC pipes carrying chemicals including sodium hypochlorite at Water Corporation.

## 8.5 Pipework Supports

PVC pipework shall be supported at specific intervals depending on the average pipe wall temperature, the density of the flow medium, the pipe diameter and wall thickness, and the stress loading on the pipeline. The pipe manufacturers typically provide published data in their design guides and will be able to advise on the spacing of the supports.

All supports shall be constructed of materials suitably resistant to sodium hypochlorite such as PVC, FRP, PE, 316 stainless steel pipe tray, brooker rod and unistrut. Mild steel supports shall not be used unless approval is granted otherwise (they would only be considered if coated with a suitable corrosion resistant coating and where contact with sodium hypochlorite or fumes is not likely).

## 8.6 Hoses and Tubings

Where used, pump suction and discharge flexible hose material shall be compatible with the chemical. The preferred hose type is braided clear PVC minimum PN16 hose (e.g. 6 mm ID/12 mm OD by [Rehau Rauiflam-E](#)). Hoses shall be protected from direct sunlight.

## 8.7 Pipework Identification and Labelling

Commissioning Plan Information
All above ground PVC pipework shall be painted in accordance with Water Corporation Standard DS95 (Appendix 3, Coating Specification K1). Paint on pipes located outside the building shall be UV-resistant. Where the pipes need to be in a more aggressive environment, a chemical resistant paint may be required. The manufacturer/paint supplier will need to be consulted regarding the suitability of the paint on PVC. Chemical pipework shall be identified and labelled in accordance with DS79-04 Chemical Safety Signage, Labelling and Markers Buried pipework or pipework installed in culverts (not exposed to UV) does not require painting, but shall be labelled for identification purposes.

## 8.8 Pipework Testing

Commissioning Plan Information
All pressure pipework shall be hydrostatically pressure tested in accordance with AS 4041 before being commissioned. Unless specified otherwise the pipework should be tested to 1.5 x the maximum design pressure. Care shall be taken to remove or isolate equipment from the lines which cannot be safely tested to the same pressure as the pipework.

## 8.9 Valves

All valve components including handles, actuators, balls, ball seals and O-rings shall be constructed of materials suitable for contact with sodium hypochlorite. Natural rubber, as well as other rubberlike elastomeric materials, including Nitrile and Buna N (NBR), shall not be used for seals, O-rings and gaskets. Plastic valves made of PVC-U with Teflon ball seals and FPM (also known as FKM and

<sup>36</sup> Georg Fischer Piping Systems Handbook.

Viton<sup>®</sup>) O-rings such as the Georg Fischer Type 546 PVC-U ball valves have shown to provide satisfactory performance.

Valves shall have tags to indicate whether they are “normally open” or “normally closed”. For critical valves, a sign should also be displayed alongside.

The ball valve inherently has a cavity between the body and the ball inside the valve where sodium hypochlorite can be trapped when it is in the closed position. Gases released from the trapped sodium hypochlorite can increase the pressure inside the valve potentially to the point of catastrophic failure. Crystallization of the caustic as the sodium hypochlorite decomposed may cause valves to jam making them difficult to operable.

To avoid this situation, ball valves with pre-drilled small-diameter vent hole on the upstream side of the ball shall be used for sodium hypochlorite applications. This modified ball effectively vents the gases while keeping inner valve surfaces constantly wetted, eliminating the conditions required for gas accumulation and caustic crystallization. The vent hole should be drilled and deburred by the valve manufacturer or a competent person as rough burrs left on the hole will damage the valve seat when the valve is later operated.

Ball valves of sizes DN50 or smaller generally perform well in sodium hypochlorite application. Larger ball valves are more prone to freezing up due to the formation of crystallite salts on the sealing surfaces of the valves. At locations where larger valves are required, butterfly and diaphragm valves can be considered as alternatives.

## 8.10 Flanges & Gaskets

All flanges shall be drilled in accordance with AS/NZS 4087 for pressure class PN16, unless a different flange standard has been adopted for the site for consistency. All flanges shall be provided with galvanised steel backing plates and 3mm full face gaskets at the flanged interfaces. The backing plates shall be hot dipped galvanised in accordance with AS/NZS 4680.

Gaskets shall be FPM (also known as FKM and Viton<sup>®</sup>) material stabilized with carbon black<sup>37</sup>. Natural rubber, EPDM, Nitrile and Buna N (NBR) are not suitable to be used in sodium hypochlorite service.

## 8.11 Fasteners

All fasteners shall comply with AS 1111.1 and AS 1112.3. Fasteners and anchorage bolts shall be hot dip galvanised in accordance with AS 1214.<sup>38</sup>

---

<sup>37</sup> DS 33 Clause 15.6.3

<sup>38</sup> 316 stainless steel fasteners are considered to have no advantage over galvanised steel fasteners due to risk of stress corrosion cracking and problem with galling.



## 9 ANCILLARIES

### 9.1 Wash Trough

A single wash trough shall be provided for the washing of pump components, valves and other equipment prior to removal from the sodium hypochlorite room. The wash trough shall be constructed of PVC. The wash trough shall be located at a height convenient for operator use and shall drain into the bund sump.

### 9.2 Safety Showers & Eyewash Units

#### 9.2.1 Number and Location

At least two safety showers and eyewash units shall be provided. One safety shower/eyewash unit shall be provided at apron/ground level outside the chemical building between 2m and 7m horizontal distance from the tanker hose connection point and the load-in panel. The second safety shower shall be provided adjacent to the Dosing Panels, on the same level, in the sodium hypochlorite storage/dosing room. The requirement for additional safety showers shall be identified through risk assessment.

All safety showers shall comply with the requirements of DS79-02 and be fitted with flow switches to alarm their use.

#### 9.2.2 Safety Shower Water Supply

Potable water shall be used to supply the safety showers and eyewash units. Where a dedicated potable water supply is not available, the safety shower supply off-take from the potable water system on site shall be located upstream of a reduced pressure zone device (RPZD). Any water usage connections associated with any chemical such as dilution or flushing of sodium hypochlorite, shall be located downstream of the RPZD to protect the safety shower supply from contamination. Hydraulic design shall ensure that there is sufficient water pressure and flow available for the safety shower and eyewash to operate when other normal services are in operation.

Backflow prevention devices and their installation shall be in accordance with the current revision of *AS3500.1 Plumbing and Drainage – Water Services* and shall be installed by a qualified plumber.

### 9.3 Hose Reels

Retractable wash down hose reels shall be provided and located such that all areas of the load-in and storage facility can be accessed with the hose. This typically means that at least two hose reels are required, one inside the storage room near to the dosing panels and one outside the building for use to hose down the load-in panel and apron. Hose shall be minimum 19mm diameter and 20m in length.

# 10 PROCESS CONTROL

## 10.1 Control Philosophy

The sodium hypochlorite dosing controller can be selected on the OIP/HMI to operate in one of two control mode, Automatic Trim or Fixed. The ‘Automatic Trim’ control mode is the normal operating control mode. In this mode, sodium hypochlorite dosing is flow-paced using feed forward ratio control from the recipient water magflow meter to the dosing controller with continuous chlorine residual trim adjustment to achieve the target chlorine residual defined by an entered setpoint. In the event of a failure in the chlorine analyser or low sample water flow, the dosing pump will continue to operate under flow paced control based on the last recorded chlorine residual.

In the ‘Fixed’ mode, the dosing controller adjusts the chlorine dose rate to the fixed dose rate value entered on the HMI using only ratio control flow paced to the recipient water flow. This control mode is used if there are problems with the chlorine analyser or sample water system.

A schematic of the control loop for dosing system 1 is shown in the figure below. The control loop for dosing system 2 is similar.

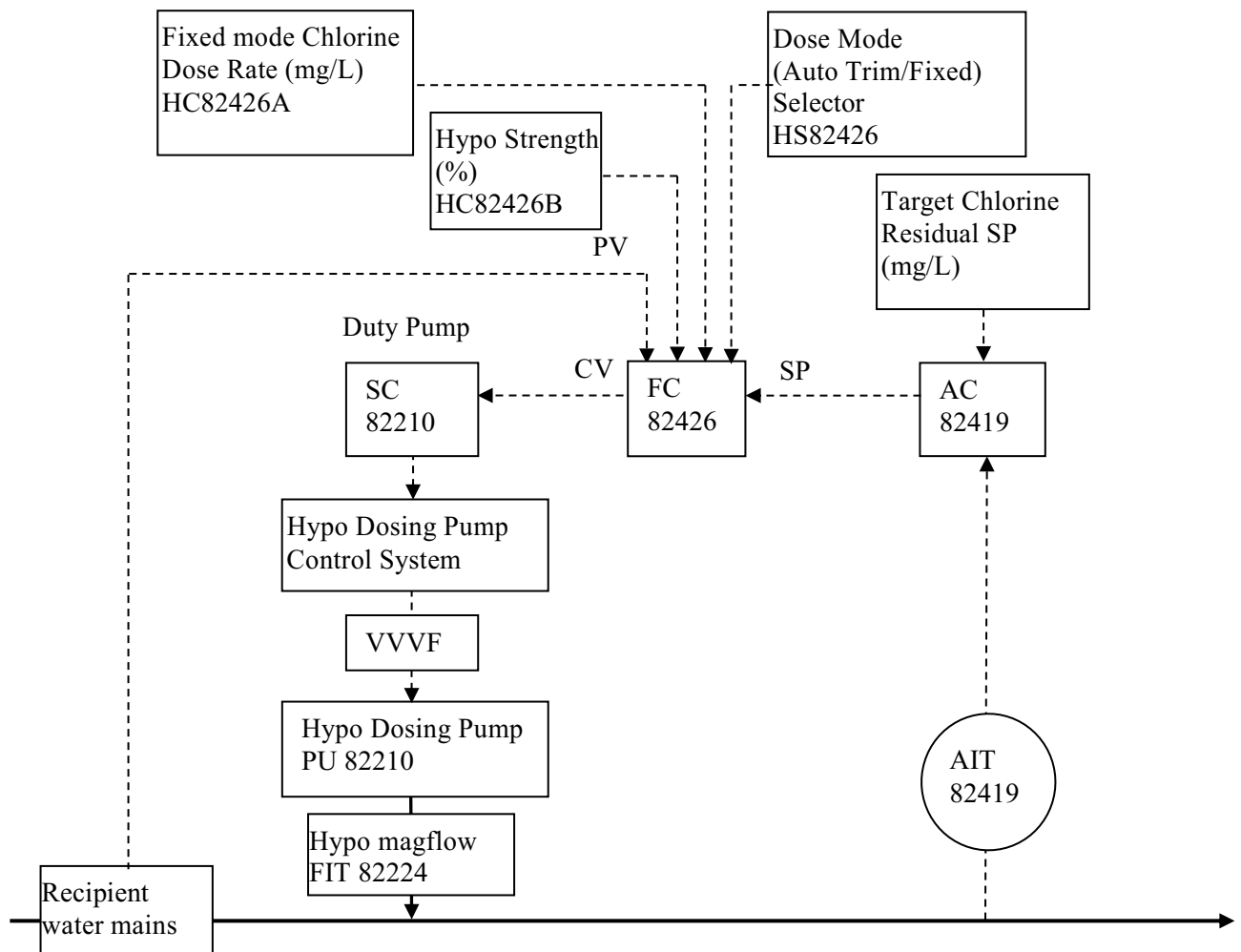

When the duty dosing system is in ‘Ready’ mode, the dosing pump will remain idle until a minimum set point flow rate is achieved in the recipient water main. Similarly, the dosing pump will stop running and the system will sit idle in the ‘Ready’ mode when the flow rate in the recipient water main drops below the minimum set point.

If the selected duty dosing system is ‘Not Available’ or failed then the standby system will automatically commence operation, providing it is in the ‘Ready’ mode operational state. The failed system will not be available for selection until the alarm condition is acknowledged and reset (i.e. the failed system will be latched out). The standby system will be allowed a period for operation before any faults shuts it down too. In this way, changing back and forth between the duty and standby system is prevented.

In the event of a plant power failure during sodium hypochlorite dosing, the system shall resume dosing automatically following restoration of power (either from mains or generator) and return of the permissive conditions such as the minimum set point flow rate in the water main. The low chlorine level in the treated water or other fault/alarm directly due to the plant power failure should not trigger a shutdown or system changeover when the power is restored i.e. a time delay shall be allowed for the chlorine residual to return to normal. However, if the system is in ‘Fixed’ mode, it shall revert to the ‘Stopped’ (off) mode in the event of a power failure, and thus the equipment shall remain off when power is restored. Automatic closing of the sodium hypochlorite storage tank isolation valve during the period of power failure is considered unnecessary as other safety measures are in place in the unlikely event of a leak.

The control philosophy is provided in more detail in the standard Functional Control Specification DS73-02.

## 10.2 Control Location

The sodium hypochlorite storage and dosing system may be controlled from the following locations:

- a) Operator Interface Panel (OIP) – Fully automatic and manual control is possible from this panel located in the viewing room. Any operational mode can be selected from this panel.
- b) Human Machine Interface (HMI) –The full dosing system is monitored from these computers located in the plant control room and in the Operations Centre at John Tonkin Water Centre through SCADA. Controls carried out on the HMIs include ‘Dosing’ and ‘Stopped’ modes and input of set points.

## 10.3 Load-in Control

Sodium hypochlorite delivery tankers often (but not always) include an on-board chemical transfer pump that is used for chemical transfers during customer deliveries. This transfer pump is powered by the tanker and therefore there is no scope for interlocking the transfer pump with the extra-high-level switch on the storage tank which may be required by AS3780<sup>39</sup>. To compensate for this preventive measure, each tank is provided with a low (re-order) level alarm and a high high level alarm (visual and audible) on two independent level measurement devices. The low level alarm is to ensure that chemicals are only ordered when the re-order point is reached, thus reducing the risk to overfill the tank significantly. This is in addition to the high level alarm to alert the tanker driver to stop the pump and the alarms associated with the bund sump level and conductivity.

## 10.4 Tank Level Alarms

The purpose of the sodium hypochlorite storage tank low low level alarm is to protect the sodium hypochlorite dosing pumps from running dry and to prevent air from being entrained in the suction pipework. Therefore the set point for the low low level alarm should be just above the invert level of the process outlet on the tank.

<sup>39</sup> In situation where the overflow line does not terminate in full view of the person filling the tank (Clause 5.7.7) or where the tank capacity exceeds 50 kL (Clause 5.7.5).

The low level alarm should be triggered at a level which corresponds to the tank being sufficiently empty to receive a full delivery of Hypo. This is also known as the re-order level. This alarm should generate a “Re-Order” message on the HMI.

The high level alarm should be set at a level which corresponds to 2 minutes<sup>40</sup> (~260L or 900L depending on the transfer pump) before a tank would commence overflowing during a filling operation. This alarm will initiate the high level light on the load-in panel and the high level alarm on the HMI.

The high high level alarm should indicate imminent overflow of the tanks and should be set at a level which corresponds to 20 secs before tank overflow. This alarm will initiate the visible and audible high high level beacon on the load-in panel which should be heard throughout the sodium hypochlorite dosing facility and load-in bay along with high high level alarms on the HMI. The hand switches provided on the load-in panel can silence this siren but the light will not stop flashing until the alarm condition has been removed.

---

<sup>40</sup> For the larger delivery truck, the transfer pump can deliver ~450 Litres/minute, whereas the smaller trucks have a 130 Litres/minute transfer pump.

# 11 LEAK DETECTION AND DECONTAMINATION

## 11.1 Sodium Hypochlorite Leak Detection within the Bund

Detection of high conductivity (say above 85 mS/cm) would generate the high conductivity alarm (AAH 82153) and indicates a spill (other than water) within the bund. The characteristic strong chlorine odour would also confirm that the spill is sodium hypochlorite. A portable pH probe or litmus paper could also be used to confirm the content of the spill.

A high conductivity alarm alone should not initiate automatic shutdown of the sodium hypochlorite dosing system. However, should the high conductivity alarm be registered at the same time as a sump high level alarm (LAH 82152), the closure of the actuated tank isolation valves shall be initiated, which will in turn shut down the dosing systems.

## 11.2 Decontamination

The design of the sodium hypochlorite dosing facility shall accommodate the following sodium hypochlorite decontamination methods.

### 11.2.1 Spills within the Bund

For small sodium hypochlorite spills neutralization can be accomplished by dilution and hosing down with large volumes of water inside the bund.

For large spills, the bulk of the spill should first be pumped into a container or tanker and carted off-site to be handled by the chemical supplier. The spill area should then be thoroughly flushed with water.

### 11.2.2 Dosing Pump, Magflow Meter and Piping Decontamination

A connection point shall be incorporated upstream of the dosing pump to provide service water for flushing and decontamination of the sodium hypochlorite dosing pump, dosing pipe, mini-magflow meter and pressure sustaining valve prior to disassembly. The flushing will reduce the possibility of occupational exposure to concentrated Hypo.

Additionally, a wash down trough should be located close to the dosing pump. This facilitates further decontamination of the dosing pump within the bund once the pump has been removed from its mounting for maintenance.

## 12 PLACARDING, LABELLING AND SAFETY SIGNAGE

The following safety signs and placards shall be provided for any sodium hypochlorite storage and/or dosing facility:

- a) A Sodium Hypochlorite Storage Placard (DS WCSS003-2 or DS WCSS003-3 whichever applicable) shall be posted near each entry door to the sodium hypochlorite storage room. These signs shall be displayed so as to be clearly visible from the normal direction of approach.
- b) Multi-Sodium Hypochlorite Signs (DS WCSS108) shall be posted on the outside wall of the sodium hypochlorite building near the unloading area and next to the personnel door to the viewing room. These signs shall be displayed so as to be clearly visible from the normal direction of approach.
- c) Storage Tank Identification & Volume Labels (DS WCSS404) indicating the tank number and size shall be posted on each tank. These labels shall be displayed at a level so that it is visible from the normal direct of approach.
- d) Corrosive Chemical Waste Tank Sign (DS WCSS055-1) should be posted on the top of the waste tank or on a free standing post near the waste tank. This sign shall be displayed so that it is visible on normal approach.
- e) Emergency Shower & Eyewash Signs (DS WCSS306) shall be posted on the wall next to the safety shower unit or attached to the rear of the shower. These signs shall be displayed so as to be clearly visible from the normal direction of approach.
- f) Maximum Fill Level Labels (DS WCSS402) shall be posted on the load-in panel. These labels shall be clearly visible to the person conducting the transfer of product into the storage tanks.
- g) Buried Chemical Line Signs (DS WCSS154) shall be used to identify buried sodium hypochlorite lines. These signs should be positioned at every change of direction or at a maximum of 50m intervals.
- h) Pipe Identification Markers (DS WCSS452) shall be posted on all pipework to indicate pipe contents and flow direction. These markers should be prominently displayed on the pipework to ensure the observer can clearly read the information.

<b>Commissioning Plan Information</b>
All signs and placards shall comply with the requirements of DS79-04 Chemical Safety Signage, Labelling and Markers

Where a sign is fitted onto or near a door, the sign shall be easily visible with the door either open or closed. This may require identical signs to be fitted to both sides of the door.

# 13 APPENDIX A: SODIUM HYPOCHLORITE PROPERTIES AND SAFE HANDLING REQUIREMENTS

Some of the properties and safe handling requirements of sodium hypochlorite are included in the table below. **Please refer to Sodium Hypochlorite Chem Alert available from the S&WB website for more information.**

Name	Sodium Hypochlorite
Other Names	Bleach Solution, Hypo, Hypochlorite Solution.
Formula	NaOCl
UN No	1791
Hazchem Code	2X
Poison Schedule	6
DG Class	8
Packaging Group	III
NaOCl concentration	12.5% to 13.0% (w/v)
S.G.	1.18 (approx) at 20°C
pH	>12
Colour	Clear green-yellow
Health Hazards	Highly corrosive – severe irritant. Avoid eye or skin contact, vapour inhalation and ingestion.
Eye	Contact with eyes may result in irritation, lacrimation, pain, redness, conjunctivitis and corneal burns with possible permanent damage.
Inhalation	Over exposure may result in mucous membrane irritation, coughing and burning sensation of upper respiratory tract. At high levels; ulceration, breathing difficulties, chemical pneumonitis and pulmonary oedema can occur.
Skin	Contact with skin may result in irritation, redness, itching, pain, rash, dermatitis and burns. Prolonged or repeated contact may result in ulceration.
Ingestion	Ingestion may result in burns to mouth and throat, nausea, vomiting, ulceration of the gastrointestinal tract, breathing difficulties, circulatory collapse and coma.
Personal Protective Equipment	Chemical Face Shield and Safety Goggles Full Length Butyl Gloves Impervious Coveralls (such as Tychem® F Coverall) PVC Boots

	<p>PVC Apron Full Face Type B (Inorganic and Acid Gas) Respirator</p> <p>Any or all of the above may be required depending on the task being carried out. Please refer to “S022 Personal Protective Clothing and Equipment and Work Wear” on the S&amp;WB website for more guidance.</p>
--	--



## 14 APPENDIX B: Sodium Hypochlorite Standard Design - Equipment schedule

The schedule of equipment for the Bulk Sodium Hypochlorite Storage and Dosing System (in Excel spreadsheet format) can be found as standard document *DS 73-01 Appendix B – Equipment Schedule*.

# 16 APPENDIX C: COMMISSIONING PLAN ITEMS

Commissioning Plan Information
As part of construction quality assurance or Factory Acceptance (in the case of modules), the slope shall be checked to confirm that requirements have been satisfied. A test shall be conducted for effective drainage and absence of ponding.

Commissioning Plan Information (Commissioning)
A 24-hour hydrostatic leak test shall be conducted on a bund prior to the filling of its associated storage tank(s) with chemical.

Hazard: Environmental impact due to failure to contain a leak.

Commissioning Plan Information
Prior to delivery to site, all tanks shall be hydrostatically tested using clean water filled to the overflow level at the workshop. The full static head is to be held for a minimum of 12 hours. Once installed, the tanks should be hydrostatically tested to the full static head again to check for any damage which may have occurred during transportation or installation <sup>41</sup> . All tanks shall be transported to site with blind flanges fixed to all nozzles to prevent dust and vermin entering vessels. If a crane is required to install tanks then soft sling rigs shall be used on the shackles so as not to damage the lifting lugs. Testing, transportation, quality assurance and other design and manufacturing requirements for GRP tanks are specified in SPS 498.

Commissioning Plan Information
Confirm accurate calibration of the tank level indication from the pressure transmitter for the specific gravity of the chemical to be stored in the tank. Confirm high and high high level alarms initiate well before the tank overflows.

Commissioning Plan Information (Commissioning)
Prior to the first delivery of chemical, the filling line shall be hydrostatically pressure tested in accordance with AS 4041 to 1.5 times the operating pressure of the tanker pump and held for a minimum of 30 minutes. Written proof of this test will be requested by the chemical Supplier and shall be made available to them. Note: The tank shall not be subject to the test pressure as it is only rated for the static head up to the overflow level.

Hazard: Equipment failure resulting in injury to personnel and damage to equipment.

Commissioning Plan Information
The pressure setting of pressure safety valves (PSVs) shall be recorded on their (red) valve tags.

Commissioning Plan Information
The pressure setting of pulsation dampeners shall be recorded on their equipment tags.

Commissioning Plan Information
The pressure setting of PCVs shall be recorded on their valve tags.

Hazard: Equipment failure resulting in injury to personnel and damage to equipment.

Commissioning Plan Information (Construction)
All above ground PVC pipework shall be painted in accordance with Water Corporation Standard DS95 (Appendix 3 Coating Specification K1). Paint on pipes located outside the building shall be UV-resistant. Where the pipes need to be in a more aggressive environment, a chemical resistant

<sup>41</sup> Water used for testing tanks at site can then be discharged through the scour valves to test the bund as well.

paint may be required. The manufacturer/paint supplier will need to be consulted regarding the suitability of the paint on PVC.  
Chemical pipework shall be identified and labelled in accordance with DS79-04 Chemical Safety Signage, Labelling and Markers Buried pipework or pipework installed in culverts (not exposed to UV) does not require painting, but shall be labelled for identification purposes.

Hazard: Personnel being unable to identify correct pipework to work on.

**Commissioning Plan Information (Commissioning)**  
All pressure pipework shall be hydrostatically pressure tested in accordance with AS 4041 before being commissioned. Unless specified otherwise the pipework should be tested to 1.5 x the maximum design pressure. Care shall be taken to remove or isolate equipment from the lines which cannot be safely tested to the same pressure as the pipework.

Hazard: Equipment failure resulting in injury to personnel and damage to equipment.

**Commissioning Plan Information (Construction)**  
All signs and placards shall comply with the requirements of DS79-04 Chemical Safety Signage, Labelling and Markers

Hazard: Personnel not being able to identify or be alerted of potential DG hazard.

**END OF DOCUMENT**